

HAVING FUN WITH TRAINS

APRIL 2017 | FREE

MRH

MODEL RAILROAD HOBBYIST

Mike Tylick on Building narrow gauge Ocean Spray box cars

» **READ NOW**

ALSO:

- Foam-based layout construction tips
- Dwarf signals with SMD LEDs
- Modern regional layout plan
- More on battery-powered DCC
- Reworking to finally get it right!
... and lots more inside!



STANDARD EDITION | LANDSCAPE



DOWNLOAD



SUBSCRIBE
(free)

• INDEX

• TABLE OF CONTENTS

ROLLING THUNDER!



Indiana Harbor Belt

Atlas HO Trainman® Plus NRE Genset II Locomotive



CSX*



Amtrak



Tacoma Rail



Metro Ports/Port of LA

The fan-favorite HO Trainman® Plus Genset II Locomotives are back, and this time you'll hear them coming from a mile away. After much clamoring from our fans, we've upgraded these fantastic locomotives and for the first time ever, they are available equipped with ESU Loksound decoders. Now you'll be able to hear the thundering roar of the horn and the chime of the bells as your Atlas Trainman® Plus Gold Series locomotive rolls around your layout. A DCC-ready Silver Series version will also be available. Rush down to your local Authorized Atlas Dealer and order yours today. For more information, visit www.atlasrr.com or use the button below.



CLICK HERE!

*CSX Licensed Product



ATLAS MODEL RAILROAD CO., INC. • 378 Florence Ave., Hillside, NJ 07205 • www.atlasrr.com • www.atlaso.com



Model Railroad Hobbyist | April 2017 | #86

STAFF CREDITS

(Updated 3/24/2017)

Front cover: Mike Tylick explores the background of these Ocean Spray narrow gauge box cars in the prototype, and then shows the steps for accurately modeling them.



ISSN 2152-7423

Editorial Staff

Joe D. Fugate, Publisher and Editor
Don Hanley, Assistant Editor

Production

Patty Fugate, Pasteup and Layout
Joe Brugger, Copy Editing
Mike Dodd, Copy Editing

Technical Assistant

Jeff Shultz

Advertising

Les Halmos, Account Manager
Daniel Nava, Advertising Assistant
Jean-François Delisle, Marketing Assistant

Columnists

Richard Bale, News and events
Jeff Shultz, News and events
Les Halmos, Modular railroading
Larry Smith, Narrow Gauge/Shortlines
Bruce Petrarca, DCC
Ken Patterson, Reporter at large

Special Correspondents

Joe Brugger, Questions & answers

Issue password: Apr2017

Published for the glory of God. [What's this?](#)

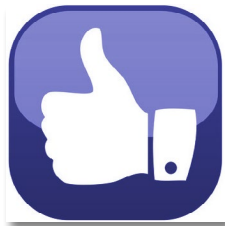

MRH SPONSORS

A - E



acculites.com



americanlimitedmodels.com



railroadhobbyshow.com



anemodel.com



archertransfers.com



athearn.com

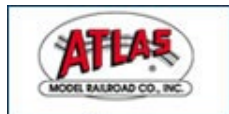

www.atlasrr.com



bachmantrains.com



bachrus.com



backdropjunction.com

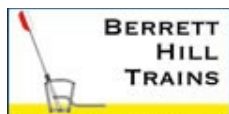

berretthill.com/trains



blairline.com



bowser-trains.com



coffmaneng.com



www.digitrax.com



esu.eu/en

F - R



www.handlaidtrack.com



foxvalleymodels.com



www.iascaled.com



lights4models.com



litchfieldstation.com



model-trains-video.com



modelrectifier.com



monstermodelworks.com



stores.ebay.com/Motrak-Models



mtalbert.com



ncedcc.com



nickandnoradesigns.com



nwhs.org



www.pwrs.ca/main.php



rapidotrains.com



ringengineering.com



rustystumps.com

[Vendors: Get your clickable logo here ...](#)

[Vendors: Get your clickable logo here ...](#)

MRH SPONSORS | 3

S - Z



sanjuancarco.com



scaletrains.com



selectmodelrailroads.com



soundtraxx.com



sodigi.com



sbs4dcc.com

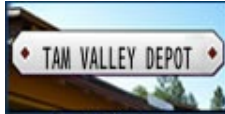

tamvalleydepot.com



tcsdcc.com



tonystrains.com



trainmastermodels.com



traintekllc.com



tsgmultimedia.com



walters.com

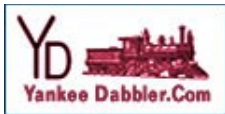

yankeedabblers.com

[Vendors: Get your clickable logo here ...](#)

Looking for something? Check the MRH Marketplace!

Take me there!



AN AMTRAK® ICON REALIZED

ANNOUNCING

Formed in 1971, Amtrak took over operation of most of America's passenger trains with an assortment of old locomotives, primarily decades-old E-units. The carrier worked with EMD to design new passenger locomotives and the result was the SDP40F, Amtrak's first all-new locomotive. With 150 built, the SDP40F became the face of Amtrak in the mid-1970s as they were found on the head ends of passenger trains from San Diego to Washington DC and from Seattle to Miami. In the early 1980s, eighteen surplus Amtrak SDP40Fs were acquired by the Santa Fe Railway and added to their freight locomotive fleet. Athearn® is excited to be able to add this iconic locomotive to the Genesis® line of high-quality models.

Amtrak Specific Features Include:

- Illuminated Gyrallight
- Illuminated UDE ("Big Hole") Light

- Leslie S4T and SL4T Air Horns
- Cab Interior



Santa Fe "hitch hauler" SF40-2 version shown



Low profile fans and roof-line details variant



Amtrak style Leslie S4T horn



Amtrak style pilot, with steam line access door snow plow.

VISIT ATHEARN.COM FOR COMPLETE LIST OF FEATURES. ORDER TODAY, QUANTITIES ARE VERY LIMITED!

HORIZON
H O B B Y

VISIT
Your Local Retailer

CLICK
Athearn.com

CALL
1.800.338.4639

SERIOUS FUN™

©2017 Horizon Hobby, LLC. Athearn, Genesis and McHenry are registered trademarks of Horizon Hobby, LLC. Amtrak and the Amtrak logos are registered service marks of the National Railroad Passenger Corporation. All other trademarks, service marks and logos are property of their respective owners. Final models may vary slightly from photos shown. 5461



TABLE OF CONTENTS

FEATURES

Ocean Spray narrow gauge boxcars

MICHAEL TYLICK

Scratchbuilding these interesting cars in wood



Dwarf SMD LED searchlight signals

JASON MILLER

Getting a true tri-color aspect for your signals



Modern Central Oregon & Pacific plan

GREG BAKER

The "One Module" Challenge grand prize winner

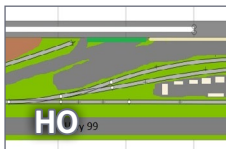

Converting to a new DCC system

ERIC MILLER

Moving to a new DCC system as needs change



Creating a 3D effect for a city

BRUCE EDGAR

Adding more depth to your layout city scenes



TABLE OF CONTENTS | 2

COLUMNS

MRH Q-A-T: Power districts, timetables, and more

compiled by JOE BRUGGER

DCC Impulses: Wireless battery-powered DCC, part 2

BRUCE PETRARCA

Getting Real: Finally getting it right

JACK BURGESS

What's Neat: Foam-based layout tips, and more

KEN PATTERSON

Photo feature: Yes, it's a model

compiled by DON HANLEY

Derailments: Bizarre facts & humor

compiled by the MRH STAFF

NEWS and EDITORIAL

Publisher's Musings: One module challenge winners

JOE FUGATE

News & Events: April 2017

RICHARD BALE & JEFF SHULTZ

Reverse Running: Don't need no stinking staging

DON HANLEY

ALSO: MRH Marketplace | Subscriber extras

More of Everything... Without Spending More

HO Scale Tier 4 GEVo • Due Summer 2017

Scene and photography by Ken J Johnson
Preproduction model shown



See All 7 Railroads and Preorder Now

More of What?

 MORE Separately Applied Detail	 MORE Lighting: Operating red DPU light	 MORE Features: Rotating Bearing Caps	 MORE Sounds: Two "Sugar Cube" Speakers	 MORE Pulling Power: over 50 cars	 DCC & Sound Ready - \$149.99	 DCC & Sound Equipped - \$224.99
---	---	---	---	---	---	---

This product is made under trademark license from General Electric (GE).
© 2017 ScaleTrains.com, Inc. ScaleTrains.com, Rivet Counter and respective logos are trademarks of ScaleTrains.com, Inc.
ScaleTrains.com, Inc. 7598 Highway 411 Benton, TN 37307
844-9TRAINS 844-987-2467 International 423-299-3689



Model Railroad Hobbyist | April 2017 | #86

PUBLISHER'S MUSINGS

editorial

JOE FUGATE



Click here to rate or comment on this article

ONE MODULE CHALLENGE WINNERS

OUR LATEST ONE MODULE CHALLENGE CONTEST

has ended, we've judged the entries, and we have selected the winners. But before I announce the winners, I'd like to comment on the contest.

This is the second year in a row where we've done a "TOMA" (the "one module" approach) contest. If you've been following the development of TOMA here in MRH, then you know it's basically applying modular / sectional methods to building home layouts instead of show layouts.

We got more contest entries this year than last year, and the overall quality of the entries was better than last year (which was the contest's first year). However, we didn't feel this year's entries were quite as innovative as last year's entries.

To score the entries, we use these categories:

Originality: How fresh and creative is the entry? How much does it demonstrate inventive high order thinking and planning from beginning to end? Score zero to ten.

PUBLISHER'S MUSINGS | 2

Adaptability: Does the entry provide good options for making modifications and creating other versions? Score zero to ten.

Assumption of skills: What skill level is needed if the entry was to actually be built? Does the entry take the needed skills for granted or does it explain the process well for lesser skilled modelers? Score zero to ten.

Maintaining interest level: How well does the entry accommodate maintaining an evolving interest level on the part of the modeler? Could it be the start of something great? Score zero to ten.

TOMA vision: How well does the entry illustrate using TOMA concepts on a home layout? How clever are the steps for getting from a single module to a full layout? Score zero to ten.

ADVERTISEMENT



CRAFTSMAN KITS



Our instruction manuals are second to none!
CHECK IT ALL OUT AT
WWW.RUSTYSTUMPS.COM
 THE QUALITY IS INSIDE BECAUSE OUR NAME IS OUTSIDE

ADVERTISEMENT



**COMING SOON
IN HO SCALE!**



We plan to produce an HO Scale version of our very popular Mt. Albert Lumber Yard kit later this year. Please watch our website and Facebook page for more details.

ADVERTISEMENT



Announcing our next Limited Run
PWRS / Micro-Trains® Car!!!

**Canadian National (CN) &
British Columbia Railway (BCOL) 4-packs**
50' Gondola, Fishbelly Side, w/ Drop Ends, w/ Tie Load



- | | |
|--------------------------|-------------------------|
| Canadian National | BC Rail |
| - CN road mark | - BCOL road mark |
| - brown | - green, dogwood scheme |
| - lightly weathered | - lightly weathered |

PACIFIC WESTERN RAIL SYSTEMS
SPECIAL RUN CAR

Pacific Western Rail Systems

NORTH AMERICAN RAILCAR CORPORATION
 NORTH AMERICAN RAILCAR CORPORATION



**National Steel Car Potash
Service 4300 cu. ft. 3 Bay
Covered Hopper**

K+S Potash Canada
(NSCX)





Archer
FINE TRANSFERS
PROUDLY SERVING MODEL BUILDERS SINCE 1989

THE ORIGINAL
SURFACE DETAILS™

WE NOW HAVE MORE THAN 130 SHEETS OF RIVETS, LOUVERS, TREADPLATE, WELD SEAMS AND MORE CAST ONTO MICROSCALE CLEAR DECAL FILM

LOW SHIPPING:
DOMESTIC USA ORDERS \$2.80
INTERNATIONAL ORDERS \$9.95

CLICK HERE TO VISIT OUR WEBSITE!

Archer Fine Transfers • PO Box 1277 • Youngsville, NC 27596 • USA
(919) 570-1026 • info@archertransfers.com • archertransfers.com

Archer Fine Transfers 3D decals have revolutionized kitbashing and scratchbuilding. Putting rivets or other low-relief details like louvers or weld seams on your models is now as easy as applying decals.
Joe Fugate, Publisher/Editor Model Railroad Hobbyist

MADE IN THE USA

**TRINITY 3281
IN STORES NOW**



Norfolk Southern -- 12 #s

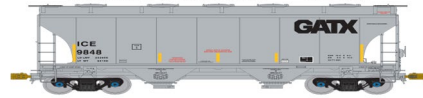

ICE-GATX -- 8 #s



Winchester & Western -- 12 #s



NRLX Ciment Quebec -- 12 #s



HWCX -- 7 #s

American Limited

www.americanlimitedmodels.com



PARLOR

**HO SCALE NEW HAVEN PARLOR CARS
ORDER DEADLINE MAY 15TH
CLICK HERE**

PUBLISHER'S MUSINGS | 3

Creativity: How imaginative or inventive is the entry? How “out of the box” is the thinking behind the design? Score zero to ten.

Submission quality: Is the entry detailed and complete or is it sketchy and lacadasical in structure? How much work would be needed to get the entry ready for publication? Score zero to ten.

We had five MRH staff members each indepently score the entries and then we combined the scores to get an aggregate score.

Because we use an aggregate of all the individual scores, our hope is to remove any personal bias and give us the overall best entries based on a group consensus.

By using this aggregation process, we're never sure who will win until the last staff member votes and we tally up the scores. It can be a surprise for us as well. In this case, a Siskiyou Line prototype-based plan won. No bias on my part, we can assure you!

PUBLISHER'S MUSINGS | 4

Here are the winners:

Grand Prize - Greg Baker

CORP Weyerhaeuser (Proto Siskiyou Line to Divide, OR modern era)

First Place - Peter Vassallo

Easton Lumber Company (Freelanced logging line)

Second Place - Scott Williamson

Port of Tacoma (Freelanced ocean port switching line)

Third Place - Jeremiah Shoemaker, Blake Freudenberg

Calumet Central (Protolanced copper mining in Michigan)

Honorable Mention - Dennis Snyder

1954 AT&SF (Proto San Diego to Pasadena)

Honorable Mention - James Moe

Twin Ports (Freelanced Great Lakes port switching)

Congratulations to the winners! We will be publishing these entries in the coming months and the winners will be getting paid for the articles as well as getting a bonus payment based on how they placed in the contest.

We think you're going to enjoy the articles that result from these entries. They're helping us further illustrate using TOMA to do a home layout. We're publishing the Grand Prize winning entry by Greg Baker in this issue.

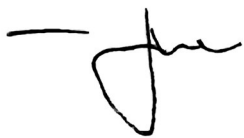

[Click here to rate or comment on this article](#)

ADVERTISEMENT



Click to WATCH the VIDEO NOW!

HO SCALE

NEW

ALLEGHENY TRANSIT - PITTSBURGH
Item No. 60505

GET ON BOARD FOR AN EXCITING RIDE!

PCC STREETCAR with SPARKING TROLLEY POLE AND SOUND

Bachmann's new HO scale PCC Streetcar features realistic simulated sparking at the end of its trolley pole. This DCC-sound equipped model includes a Sound Value *SoundTraxx*® package with bell, stop request, opening/closing doors, trolley pole adjustment, traction motor, electrical arcing sounds synchronized to spark effects, and generator — all in 16-bit polyphonic sound. Updated to sit lower over the wheels per the prototype, this model includes new enhanced details on the wheels and truck brakes. Get on board NOW for an exciting, sound-filled ride!

Features include:

- DCC sound-equipped
- simulated sparking trolley pole
- operating headlight
- illuminated interior
- die-cast power truck
- passenger silhouettes

DCC® SOUND VALUE ON BOARD

SHIPPING NOW! MSRP \$225.00 each



NEW

SAN DIEGO
Item No. 60501



NEW

PACIFIC ELECTRIC
Item No. 60502



NEW

PHILADELPHIA TRANSIT COMPANY®
Item No. 60503

Click to learn more



NEW

CHICAGO
Item No. 60504



NEW

NJ TRANSIT
Item No. 60506



Bachmann Industries, Inc. • 1400 East Erie Avenue • Philadelphia, PA 19124 USA • www.bachmanntrains.com

PUBLISHER'S MUSINGS | 5

MRH 2016 Survey, Time spent on the hobby?

Here is the response to our from our 2016 reader survey question asking our readers how much time they spend on the hobby. The statistical validity is +/- 2.5% with a 95% certainty.

How much time do you spend on the hobby?

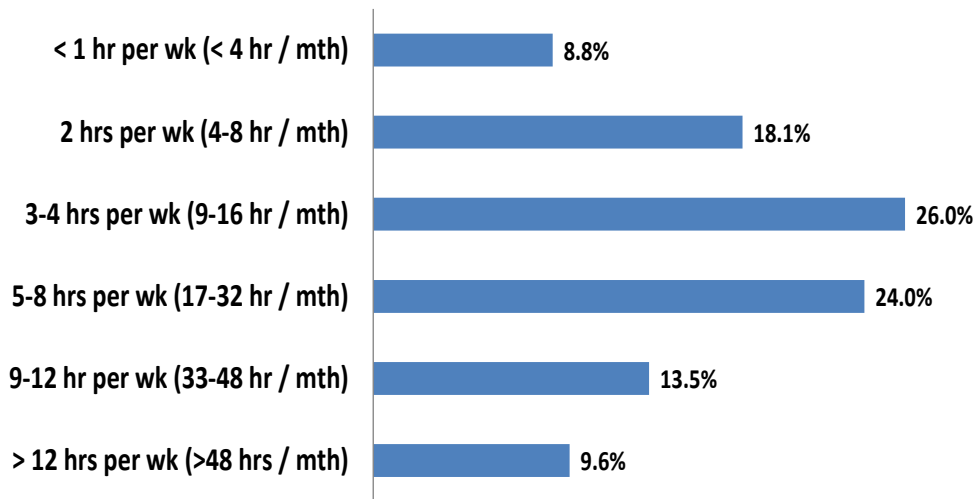

Over 70% of our readers say they do the hobby at least three hours a week, with almost a quarter of our readers spending at least nine hours per week on the hobby. That is more than a full eight hour working day each week. Put another way, it is approaching a full 40 hour work week on the hobby per month!

Conversely, one out of five spend two hours per week or less.

We didn't ask if this is time outside of reading MRH, but we hope so! Otherwise those who spend two hours or less per month aren't getting a lot of actual modeling time in – or they're reading MRH *awfully* fast ...

ADVERTISEMENT

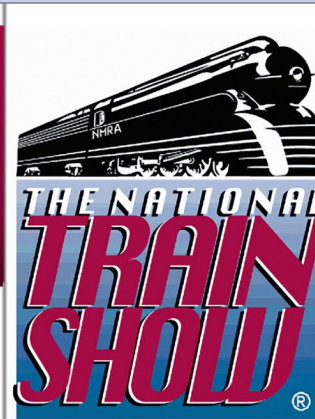

2017 National Train Show

August 4 - August 6, 2017

in ORLANDO, FLORIDA

Get the details >>

(click me)

Fun for the Whole Family

From your littlest engineer ...

To the most experienced Model Railroader



- The World's Best Known Manufacturers
- Over 180,000 square feet of exhibit space
- Hands-On Demonstrations
- 44,000 Sq. Feet of Modular Layouts
- Ask The Collectibles Appraiser
- The Incredible Lego® MiniLand

★ LAST ISSUE'S RATINGS

The five top-rated articles in the [March 2017 issue](#) of *Model Railroad Hobbyist* are:

- 4.8 What's Neat: Just Plug lighting system
- 4.7 Re-work a plastic steam locomotive
- 4.7 DCC projects using the Arduino
- 4.7 Nickerson switching puzzle
- 4.7 March 2017 News

Issue overall: 4.7

Please rate the articles! Click the reader comments button on each article and select the star rating you think each article deserves. Thanks! ■

ADVERTISEMENT

ADVERTISEMENT

HO GP60M, GP60B AND GP60 LOCOS



NOW AVAILABLE !



DC OR DCC WITH SOUND!



www.foxvalleymodels.com



NICK & NORA DESIGNS

Uniquely inspired craftsman kits
Craftsman Structure Kits in HO & N
 Detail Parts,
 laser cut shingles,
 HO Vehicles, Tru-Color Paints,
 glues, tools & more!
www.nickandnoradesigns.com

Norfolk and Western Historical Society

Brand New Video!
Feature length DVD or Blu-Ray.
The official story of 611's 2015 restoration to operating condition.
How can I add this great disc to my collection?

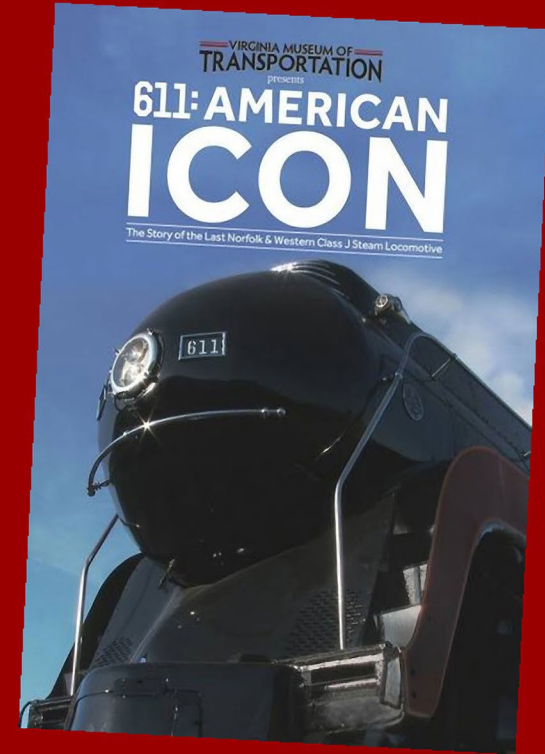

Click Here!

The MRH Media family

**Model Railroad
Hobbyist magazine™**

mrhmag.com

store.mrhmag.com

**Model
Railroad
Hobbyist
Store**

Brought to
you by
MRH
MEDIA

trainmasters.tv



Visit TrainMasters TV ...



MRHMAG.COM



Model Railroad Hobbyist | April 2017 | #86

MRH Q-A-T column

compiled by
JOE BRUGGER



Click here to rate or
comment on this article

? QUESTIONS AND ANSWERS

Power districts and DCC phases

Q. I am helping a friend build a new layout with about 500 linear feet of track. We are using a Digitrax system and are planning to use two DB150s (AutoReversing DCCCommand Station/Booster). My question is: when running the main bus cables should half the bus wiring go to just one DB and the other half of the wiring go to the other DB? That is, do we keep the bus wiring totally separate for the two electrical districts? If so, will a train seamlessly slip from one district to another?

A. Kevin Jones: Each power district must be electrically isolated from the rest. Are you using both DB150s as boosters, or is one being used as a command station?

Joe Fugate: Yes, the two power districts must be kept separate. It's best to gap the two rails directly across from each other so the locos make a smooth transition from district to district.

► MRH QUESTIONS, ANSWERS, AND TIPS

• INDEX

• TABLE OF CONTENTS

MRH Q-A-T | 2

As long as the rails from each of the two districts are in phase, the locos will roll right over the gaps without any hesitation. If the rails on either side are out of phase, the locos will abruptly halt at the gaps. If this is a problem, swap the power feed connections around on one of the boosters to get them in phase. DCC doesn't have polarity, but somewhat like alternating current, it does have a phase, and the leads need to match and go from the same connection on the booster to the same rail on the track. Also, fill the gaps with styrene so they can never close up. If they close due to rail movement, or expansion and contraction, it can damage your boosters.

ErieMan47: Putting the gaps that separate the power districts directly across from each other makes total sense to me. However, when I installed DCC Specialties PSX circuit breakers to set up my DCC power districts, the instructions very specifically said to offset the gaps by about 1/8”.

I also have a PSX-AR auto-reverse controller, and I can somewhat understand why you might want that offset for the reverser, but not for the regular breakers. I emailed tech support for the PSX and they explicitly said “we really mean 1/8” offset for the regular PSX breakers, not just the auto reverser.” I asked “can you tell me why?” They answered “to avoid phase polarity errors.” That made no sense to me, and I did not pursue it further with them. I followed their recommendation and used 1/8” offsets, and have not experienced any problems.

I can only guess that what they might have in mind is that if you wired the adjoining power districts with the phases incorrectly reversed, then when a metal wheelset crosses the gap, if the gaps are precisely opposite each other, there is a fault mode that stresses the PSX circuitry. But, I am almost positive that the PSX breakers only open up one of the DCC phases if they trip, so I am still left puzzled.

MRH Q-A-T | 3

Pelsea: To understand the need for offset gaps, think of what happens in the instant the first wheel bridges the gap. If the rails are out of phase, you have the A rail of one district shorted to B of the second district. This will produce whatever current 14 volts will push through the wheel resistance (very small) and the protection will kick in, hopefully just in time to prevent the circuit from smoking. Now, if both wheels bridge the gap at the same instant, you not only have A1 shorted to B2, you have B1 shorted to A2. That will produce double the current hit. Maybe the protection will kick in in time, maybe not.

Current protection can't be quite instantaneous, because you have to allow for capacitor inrush and other things as the blocks and engines power up. You choose output transistors based not just on continuous current handling, but on transient current rating – how much for how long. If the engineer who specified the transistors says offset the gaps, then offset the gaps. I would think it very difficult to actually get the gaps perfectly aligned, so if you don't have deliberately staggered gaps, don't panic, just put it on your “get around to it” list.

Catch up on current gap developments at mrhmag.com/node/29010.

Timetable question

Q. I found online a copy of the BNSF Twin Cities Division Timetable, dated November 17, 2004. I'm confused by some of the columns. For example, one column is titled “Rule 4.3” with cells “BMJT”, “R”, “JU” and “JTU.” Another column is titled “Type of Oper.” with cells “TWC” and “Rule 6.28.” This particular timetable is for the Glasston Subdivision. I can't find anything that indicates what the rules are or what the abbreviations are.

— Kent Frazier

MRH Q-A-T | 4

A. David Husman: You can Google “General Code of Operating Rules.” Rule 4.3 just says the timetable can use abbreviations. Somewhere in either the timetable or special instructions it says what the codes mean (i.e., “T” might mean the station has a turning facility, a wye).

“Type of Oper” is what method of main track authority is used. TWC is track warrant control, track warrants, verbally transmitted authorities. Rule 6.28 concerns sidings of an assigned direction (in other words, the sidings are used by trains in one direction or an eastward train uses one siding and westward trains use the other).

MoeLine: I didn’t have a BNSF timetable available, but the characters are somewhat similar from one railroad to another. On the UP the B stands for base radio, M is manual interlocking, J is a junction, T is turning facility, R may be restricted limits. But you have to find the right key for your company.

6.28.1 is what Dave mentioned, and the rest of 6.28 is about movement on other than main tracks, which is what sidings are in TWC. I can’t find anything for U, so that is a BNSF exclusive character. TWC (track warrant control), CTC (centralized traffic control), and others are extremely important to railroaders so they know which type of territory they are using in order to have the right form of main track authority for their train.

AJ Kleipass: I found these codes tucked into the special instructions PDFs from the same place you probably found the timetable, fobnr.org/timetables/bnsf/phase4/index.htm. I am a little surprised that they aren’t in the timetable itself, but I guess if you are a qualified engineer you should know those sorts of things by heart already.

ADVERTISEMENT

LIGHTS 4 MODELS

Add a new dimension to your layout
OK Used Cars was Chevy's brand name
for their used-car trade-in division,
started in the mid-1920s.

* orders with new signs get free shipping *

10% Off
In Stock
HQ Sound
Boards

find us on [facebook](#)

Shop Now

ADVERTISEMENT

Checked us out lately?

- ✓ HO/N and now O scale products too!
- ✓ Laser-cut Structures & Bridges.
- ✓ Advertising & Storefront Signs.
- ✓ Highway Signs, vintage & modern.
- ✓ New Detail Items.
- ✓ Laser-cut Grade Crossings.
- ✓ Billboards, roadside & rooftop.
- ✓ Laser-cut Graffiti Decals
- ✓ 1000's of satisfied customers.

WHAT'S NEW? Established 1993...
Blair Line

ADVERTISEMENT

Want it on Blu-ray?

Selected titles are now available on Blu-ray disc in spectacular HD!

CLICK FOR BLU-RAY

TSG TSG Multimedia

ADVERTISEMENT

Select MODEL RAILROADS

Design & Build Services For Discriminating Modelers

WE WILL:
Complete Unfinished Railroads
Fix or Rebuild Bad Railroads
OR
Design & Build A Custom
Railroad Of Your Dreams

CLICK HERE FOR OUR WEBSITE
www.SelectModelRailroads.com
(844) 872-4670

PACIFIC DIVISION										
WESTWARD					EASTWARD					
Rule 6(A) Signs	Length of Siding in feet	Station Numbers	Line Segment	Mile Post Location	Distance from Snoqualmie Falls	11th Subdivn MAIN LINE				
						STATIONS				
						Telegraph Offices and Calls				
		65832			0.0	SNOQUALMIE FALLS				
BETWEEN MAPLE VALLEY AND SNOQUALMIE FALLS, CMS+P&P TIME TABLE AND SPECIAL INSTRUCTIONS GOVERN.										
BCJKPRY		65922	410		22.7	28.2		MV	28.2 MAPLE VALLEY	ABS
BJOPQRY	3,660	65637			12.1	38.4		RT	10.2 RENTON	
BCIJ PRXY		16004			9.7	40.8		BI	4.3 BLACK RIVER	
PY		02205			5.4	45.1	Dbl. Track		4.3 VAN ASSELT	
CIJ PQY		02203			3.4	47.1			G	
BCIKQ PWYZ		02201			2.0	48.5		SF	1.4 SPOKANE ST. (Stacy St. Yard)	

GN signal aspects as contained in the 1967 edition, Consolidated Code of Operating Rules are in effect between Maple Valley and Spokane St., except UP interlockings at Argo and Black River.

1. From Burlington Northern Time Table 17 for the Portland-Seattle Region, effective Oct. 1, 1979. Codes appear in the far left-hand column.



[Click here to rate or comment on this article](#)

MONSTER
modelworks

New O Scale Kit Release Triple J Repair



*What type of repair shop do you need?
These guys can fix anything.*

www.monstermodelworks.com

Backdrop Junction
Your Stop for Railroad Backdrops

[Click Here](#) →

For the Finest in Custom
Designed backdrop



www.backdropjunction.com

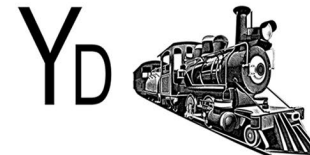

Yankee Dabblers – Track 33

FREE SHIPPING
ON ORDERS OVER
\$100.00

YD Specializes in DCC
Sales-Service-Installation
YD provides the BEST for LESS



CLICK AND SAVE TODAY!

YD installs DCC or RailPro in your engines
Technical Coordination (727) 457-9227 9AM to 9PM EST



GCOR Rule 4.3 Timetable Characters

- A..... Automatic Interlocking
- B..... General orders, notices, and circulars
- C..... Radio communication
- g..... Gate, normal position against conflicting route
- G..... Gate, normal position against this subdivision.
- J..... Junction
- M..... Manual interlocking
- P..... Telephone
- R..... Restricted Limits
- S..... Railroad crossing protected by permanent stop sign
- T..... Turning facility
- U..... Railroad crossing not protected by signals or gates
- X..... Crossover
- X(2) ... Multiple crossovers
- Y..... Yard Limits

Painting plastic trucks

Q. Plastic freight car trucks are great for detail and rolling qualities, but it sure is hard to keep paint on them. We have had to use a truck tuner to help cars to roll better, or have needed to swap out wheelsets and as soon as you touch or twist the truck, the paint pops off and you're ruined a really visible part of a detailed model. What paint do people use on styrene and Delrin trucks, and how do they make it stick through handling and maintenance?

— Graham Line

A. Terence510: The trick I use is to clean the plastic trucks with alcohol first. Any fingerprint grease or oily residue, and the paint will just fall off. Then I apply a very faint coat of airbrushed



2. An alcohol wash cleans grease and other residues from slippery engineering plastics, leaving a clean surface for painting and weathering. On the left is an Atlas Master Thrall 2743 gondola with ExactRail trucks and ExactRail 33" .088 wheels. On the right is a superdetailed Athearn blue box 57-foot reefer with the same type of trucks and wheels. *Terence Boardman models and photo*

enamel paint, usually matte black mixed with a bit of rust color. When it's dry, I apply matte acrylics to do the weathering rust and grime to suit.

Sometimes I will use a hobby knife to scrape and clean away any flash from the molding process, and lightly sand on the flat areas with 1200-grit sandpaper to give the paint something more to adhere to. I don't have any issue with paint flaking off, even after lots of wheel swaps.

LouieX2: Try priming with polycarbonate paint that is used for R/C car bodies. Tamiya has an extensive line you might check out.

Tom Haag: I use a very simple, cost-effective method that works great! I scrub the Delrin trucks with a toothbrush and a cleanser powder such as Bon-Ami [3] or Bar Keepers Helper. The mild



3. Non-scratching cleaners like Bon Ami and Bar Keepers Helper take the shine off slippery plastic trucks. Mix a paste of water and cleaner, and scrub with an old toothbrush. *Bon Ami photo*



4. Prep plastic trucks for paint and weathering by scrubbing them with a paste of water and cleanser. Left, an untreated truck; center, an alcohol-washed truck; and right, a Bon Ami-prepped truck. *Josef Brugger photo*

cleanser lightly etches the engineered plastic which results in a great surface for painting. No need for special surface preps, special paint, or – my favorite – soaking the plastic in vinegar. Or was it Windex? You can tell how it works by comparing a shiny black plastic truck that has not been scrubbed to one that has ... the dry, scrubbed truck has a dull off-black look [4].

I have used this method for years for all my painting of engineering plastic parts from trucks, locomotive side frames, handrails, Kadee coupler pockets to the Delrin parts on Kadee freight cars. Paint seems to stick to these scrubbed parts just as well as to styrene.

Bill Brillinger: I usually spray trucks with a heavy coating of Testors Dullcote. I've never had paint flake off, even on some 25-year-old pieces I still have around today.

BR GP30 2300: The only make of trucks I have painted were 20 pairs of Tichy arch bar trucks, as these are molded in gray styrene. Delrin trucks I spray with Testors clear flat, and use mostly weathering powders and chalks.

More at mrhmag.com/node/29213.

💡 TIPS

Painting peel-n-stick windows and trim

When assembling a laser-cut wood building kit I thought about the easiest way to paint the peel-and stick window frames and building trim. Painting the entire sheet would be easy, but would leave the edges of the trim parts in the natural “burnt wood” color from the laser cutting. I wanted some color on the edge to match the color used on the face of the parts. Brush-painting the edge of each part would be laborious, particularly since the building has a lot of windows!

An old can of spray adhesive provided an inspiration. This method allows you to easily paint the entire part and makes it easier to remove the backing as well.

— George Van Duyne

MRH Q-A-T | 10

- Remove the peel-and-stick parts from their sheet. Sort them as to type and the color you will paint them.
- Spray a generous coat of adhesive on a sheet of paper. Any kind of paper will do. I used some old 3-ring binder paper. Caution: Spray adhesive has volatile components similar to spray lacquers or enamel paints. Use only in a well-ventilated area and consider wearing a good quality respirator.
- Place the peel-and-stick parts on the paper sheet, spacing the parts far enough apart to paint the edges easily.
- Spray or brush-paint the parts with your favorite building paint. I use craft paints in my airbrush for buildings. Inexpensive rattle-can spray paint would also work.
- When ready to apply the parts to the building, use scissors to cut each part from the sheet. Don't trim closely with the scissors. Just cut around the part.
- Most of the time, the spray adhesive is strong enough to pull the backing free of the part. Hold the sheet of paper, and use a modeling knife to lift the part free of its backing and apply it to your model.



[Click here to rate or comment on this article](#)

💰 GET PAID FOR YOUR TIP

We pay \$25 per tip we publish, or \$40 each if the tip also includes a photo or finished drawing. [Click here and select article type TIP.](#) ■

MRH Q-A-T | 11



5-6. (Left and below) After applying spray adhesive to the paper, the window frames and the trim parts with their self-stick backing are affixed to the paper and sprayed with paint.

Generally the spray adhesive is strong enough to pull the self-stick backing free from the part.

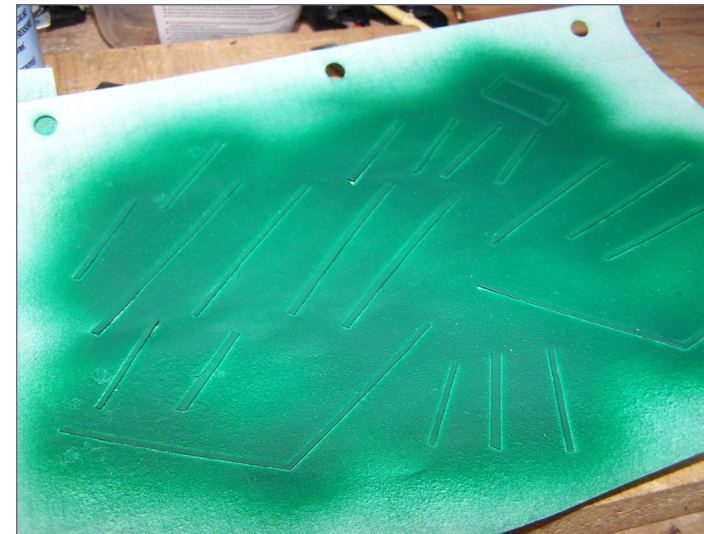

[Click here to rate or comment on this article](#)



Complete Train Control

Introducing the **EVOLUTION™**

The next Evolution in Complete Train Control®

- Premium Advanced 5/8 Amp Starter Sets.
- Starter sets are available as standard tethered or duplex radio.
- The system features a DCS210 Advanced Command Station, DT500 series throttle, and includes a power supply to make getting started easier than ever.
- The DT500 series throttles can be purchased separately from the new Starter Set.

Find out more @ www.digitrax.com



Evolution (shown) | \$450 MSRP

Standard Set Includes: DCS210 Advanced Command Station, DT500 Advanced Super Throttle, UP5 Universal Panel, PS615 power supply, and a LT1 LocoNet Tester.

Evolution Duplex | \$660 MSRP

Duplex Set Includes: DCS210 Advanced Command Station, DT500D Advanced Duplex Throttle, UR92 Universal Panel, PS615 power supply, and a LT1 LocoNet Tester.

Got Steam?

Full Throttle Steam
Available Now!!!

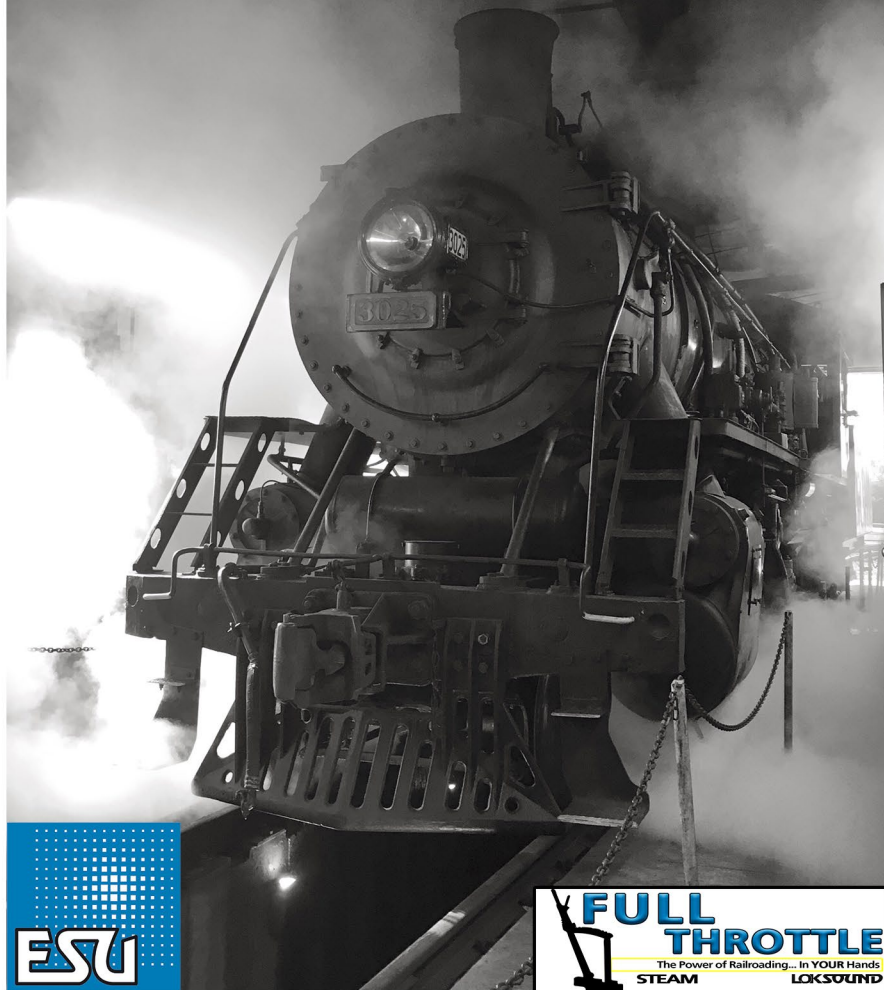

www.LokSound.com



BRUCE PETRARCA MMR
.....

Model Railroad Hobbyist | April 2017 | #86

DCC IMPULSES

column



Click here for
reader comments

WIRELESS DCC, PART 2, BATTERIES

LAST MONTH I DISCUSSED COMMUNICATING the DCC packets by radio from a hand-held cab to a mobile receiver or decoder (mrhmag.com/magazine/mrh2017-03/dcc-impulses). This month, let's look at providing motive power by battery for a truly wireless (dead track) solution. Since I'm currently knee-deep in a garden project, a lot of this column will revolve around larger batteries and the trailing cars to carry them. A future column will deal with smaller scales and their battery needs.

Types of batteries

Most folks don't want to be replacing batteries every few hours of operation, so they choose rechargeables [1]. Let's look at various rechargeable chemistry designs and focus on their advantages and disadvantages.

NiCd - Nickel Cadmium were the first small, light, rechargeable cells. They have low energy density: that is, they have

► DCC TIPS, TRICKS, AND TECHNIQUES

DCC IMPULSES | 2

rather short life compared to newer chemistries. They also suffer from memory effect: that is, if they are not completely discharged every time they are drawn down, they tend to remember the partially discharged state and head for it like a horse to the barn. As an example, if you discharge your NiCd's to 80% of their capacity and the recharge them back up repeatedly, they will drop from 100% to 80% almost immediately upon being removed from the charger. I haven't used any NiCd cells in over a decade.

NiMH - Nickel Metal Hydride are the choice for AA and AAA rechargeable cells these days. They have about double the energy density of NiCd and little to no memory effect. However, they are not really up to the task to provide locomotive power for more than a few minutes of use in a reasonably sized package [1]. I use the AAA version in my NCE DCC throttles.



1. About 12 volts and 1000 mAh of storage: ten AAA NiMH cells or three (shorter) lithium ion cells. *Bruce Petrarca photo*

ADVERTISEMENT

Make LocoNet wiring extremely simple!



ACCU-LITES, inc
Your DCC Center!

**Suitcases belong in your baggage cars,
not under you layout!**

**Introducing the DCC Vampire II ...
this guy does the job of two suitcase
connectors!
And really holds the connection good
too!**



CLICK NOW TO DISCOVER THE AMAZING VALUE!

Dealer Inquiries Accepted

ADVERTISEMENT

RailPro™

**NEW
TECHNOLOGY**

DIRECT™
RADIO



**Click Here to
Learn More**

RE RING™
ENGINEERING

NEW Starter Kit
\$399.99 MSRP

- Includes Wireless Color Touch Screen Handheld Controller and 56 Watt Power Supply
- Expandable to Virtually any Size Layout

NEW Locomotive Module
LM-3 & LM-3S

- Direct Radio RF
- Sound and Non-Sound
- New Tiny Size
- 6 Light Outputs

RailPro Model # LM-3S

For more information visit our Internet site: www.RingEngineering.com

Pb - Lead (also known as lead-acid) batteries are available in liquid electrolyte versions (like your car battery) and gelled electrolyte (like those used in computer Uninterruptible Power Supplies). They excel in high current drain applications. Due the large amount of lead in them, they are heavy. They also represent an ecological challenge for disposal or recycling. The size and weight preclude their use in model railroading, short of 7½ inch gauge (ride-on) locomotives.

Li - Lithium chemistry batteries come in several varieties. They are smaller and lighter for an equivalent energy density, compared to all the prior choices. But this comes at a cost: they are finicky to charge and relatively expensive. That said, lithium polymer and lithium ion cells are the cell of choice for model railroading. So, I'm going to focus on them in this column and just refer to them as "lithium" batteries. I use a "9-volt" lithium rechargeable battery in my Digitrax throttles.

There are also non-rechargeable lithium batteries, just to confuse the mix. Coin cells, such as are used in some command stations, are one example. Make sure you are looking at rechargeable lithiums for locomotive power uses.

Cell vs. battery

The terms are frequently used incorrectly. For example, the use of the word batteries in the paragraph headed "Types of batteries," above, probably could have been cells.

A "cell" is a single storage element. The AA or AAA "batteries" that we use in cabs are a single storage device, so they should be properly referred to as "cells." The group of cells installed in a cab becomes a "battery."

The term "battery," in general, refers to a group of things working together. This originates from the military battery, meaning a collection of artillery pieces. So, an electrical battery is a group of

cells. For example, a 12-volt car battery consists of six 2-volt cells. Each fill cap (remember those) is a different cell. Yes, for the anal-retentive folks in the group, the cells are really 2.3-volts, making the battery 13.8-volts. But we still call them 12-volt systems.

Rechargeable battery abbreviations

mAh is the energy capacity of the battery in milliAmp hours. A 350 mAh battery will supply 350 mA for an hour. Note that 350 mA is 0.35 amps, so 350 mAh would be the same as 0.35 Amp hours (Ah).

C refers to the battery capacity in mAh or Ah. For a 350 mAh battery, C = 350 mAh. This capacity is used to reference charge and discharge rates. 1C means that you are drawing out or putting

ADVERTISEMENT

TCS *WOWSound*

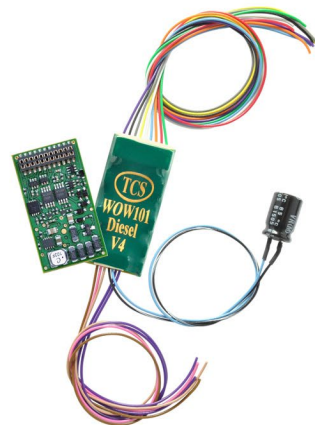

**Version 4 of WOWDiesel
NOW SHIPPING!**

**WOWDiesel Version 4 Introducing the
645 Non-Turbo Prime Mover**

All with Unmatched CD Quality Sound at
TRUE 16 bit Resolution that nobody else can
come close to!

[click here](#)

Learn why loco sound fans prefer WOWSound ...

Remember you "Rivet Counters", Sound has rivets too and TCS counts them better than anyone!

www.TCSDCC.com



2. RC style battery pack. This is a 3S 350 mAh pack designed to be discharged as quickly as 130C. Note the two connectors, one for the model and one for the balancing charger. The (two-wire) model wires are very large gauge. The (four-wire) balancing charger wires are a bit smaller. Since this pack is rated at 130C discharge, it will supply over 40 amps for about 2 minutes. Not recommended for model railroading. *Pete Steinmetz photo*

in current at the same rate as the mAh rating of the battery. For example, this 350 mAh battery being discharged at a 2 C rate would be delivering 700 mA of current. If the same battery were being charged with 175 mA of current, that would be a ½ C charge.

S refers to the number of cells in series comprising the battery pack. Four lithium cells in a battery will be referred to as a 4S pack. Since lithium cells have a nominal 3.7-volt rating, this would be a 14.8-volt battery; but it would run from 16.8 volts at full charge to 12 volts at shutoff. This gets complicated with series /parallel packs; which are beyond the scope of this column.

Lithium battery quality

There are two general hobby uses for rechargeable lithium batteries. Yes, they are usually batteries, as very few hobby systems can run on the about 4-volts from a single rechargeable lithium cell.

END OF TRAIN DEVICE

NEW SAFETY GREEN

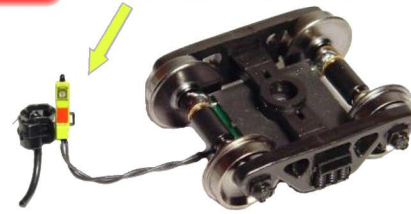

Bright Red Flashing Light!

**Installs in minutes!
No freight car modification required!**

Patented Technology - US Patent 7,549,609

Does not affect Load!

↓ Car without Load ↓

↓ Car with Load ↓



Click Here to Learn More

RE RING ENGINEERING

www.SBS4DCC.com

Please mention MRH when speaking with advertisers.

Radio controlled (RC - boat, car and, especially airplane) model usage focuses on high rate discharge, followed by as rapid a charge as possible. Frequently RC users discharge batteries above 20 amps. The RC operator wants their model back in service quickly, so looks for charge times of a few minutes. Batteries intended for this abusive environment probably will not have built-in safety measures.

Since RC batteries have their lifetime shortened by the abusive charge/discharge cycles, lower quality cells are used to keep the price down. This is the reason for “explosion proof” charging pouches being sold along with RC batteries. Also, because of the “fire-hose” charging, individual cells within the pack may develop varied amounts of charge. RC packs usually have a second connector, called a balancing connector. This connector [2] allows capable chargers of analyzing the charge level of each cell and adjusting the power being applied to it during the charge cycle to bring all cells up to 100% before shutting off.

RC-style batteries can be identified by the two connectors and the high C rating boasted about on the package. They are not the best choice for model railroading, even if they seem to be cost effective.

In model railroading, there is no need to abuse batteries in the manner that RC modelers do. We need a couple of amps of current and can charge them for a few hours. Being kinder to the batteries allows us to take advantage of electronic safeguards within the battery pack, such as over charge, over discharge, and short circuit protection. These are referred to as “protected” packs. Always use protected packs in model railroading. This kindness translates into longer life of many hundreds of power cycles, frequently about a thousand. The cells are of higher quality and the cost is higher. But the safety is worth the cost, in my opinion.

Using a trailing battery car or a quickly changeable battery will allow a modeler to have one battery for each simultaneous

operator, with one, or a very few, standby spares. One need not have one battery (or more) per loco owned -- too many batteries. I'll discuss the battery cars I built for the PCMRC garden layout later in next month's column.

Size your needs

I found that I was overestimating how much battery capacity would be needed. There are two basic methods of running model trains: around in circles at a relatively constant speed or the back and forth, start and stop of operations. My observation is that operations-style movement takes about 1/3 of the energy that constant running needs. Said another way, if a battery lasts an hour in constant running, it will probably run about 3 hours in an operations scenario.

ADVERTISEMENT



ANE MODEL
Navigator of Turnout & Digital control

LD101
Coming Soon

www.anemodel.com

The advertisement features a white digital controller with a display showing '8.888' and several buttons. To the left is a cartoon character of a yellow and black train engine. The background shows a model railway track.

ADVERTISEMENT



WAY TO GO, TRAINTEK!
Already great prices
and NOW ...
**FREE SHIPPING
ON ORDERS OF
\$79 or more***

Start saving now!

Traintek

*some exclusions apply

The advertisement features a smiling man with a grey beard and a blue shirt. A mouse cursor points to a purple button that says 'Start saving now!'. Below the button is a blue train engine. The background is a light blue gradient.

DCC IMPULSES | 8

It is easy to calculate battery capacity for constant running. Measure the DC current being drawn from the battery when the loco is running as you desire (speed and load - number of cars).

Multiply the number of amps (A) or milliamps (mA) times the number of hours you want the loco to run. That number is the battery capacity needed. For example, if your loco draws 1-¼ amps and you want it to run for 3 hours, you need a battery with at least 3-¾ amp hour capacity (3.75 Ah = 3750 mAh).

Think of battery capacity just as you would fuel tank capacity. If your car burns 3 gallons per hour and you want to run for 3 hours, you need at least a 9 gallon tank. A larger tank will cost more to build and to fill and weigh more when full. It will work just fine. Batteries are the same: higher capacity means higher cost and weight, but you will be able to run longer, too.

I built an adapter to do this testing. It has a connector on each end: one to mate with a battery and the other to mate with the loco. One lead has two banana plugs, allowing me to send the loco power through my digital multimeter, set to 10 A DC. I put the battery and my multimeter in a gondola car and ran it with each loco. I could read the running current while running around the layout [3].



3. Battery pack and multimeter set for 10 amps running in trailing gondola to verify locomotive current draw. *Bruce Petrarca photo*

ADVERTISEMENT

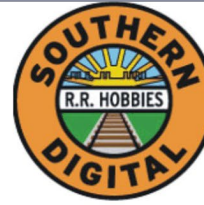

Southern Digital

Digitrax Throttle Super Sale while they last

<p>DT402 SALE!</p> <p>MSRP \$185.00 Your Price \$148.00 Your New Price \$125.00</p>	<p>DT402R SALE!</p> <p>MSRP \$235.00 Your Price \$188.00 Your New Price \$165.00</p>	<p>DT402D SALE!</p> <p>MSRP \$250.00 Your Price \$199.95 Your New Price \$179.00</p>	<p>UT-4R SALE!</p> <p>MSRP \$129.95 Your Price \$99.00</p>
---	--	--	---



DCC Conversions, Service & Support

Orders Received by 3:00 pm EST ship the same day

WWW.SODIGI.COM

E-mail: sales@sodigi.com

(770) 929-1888

(Photo's are from our N-Scale layout)

DCC IMPULSES | 9

My club's garden layout [4] (pcmrc.org/garden.html) runs a few times a year for our open houses. For that we need two hours of reliable operation running around in circles, plus set up and check out time.

I was shooting for three running hours and I wanted to use the same battery size for every loco. Off hand, I thought the big LGB F7A & F7B pair would take about 3 amps (3000 mA). So that told me that I needed about 9000 mAh or larger batteries. When I looked at the price to buy three of these brutes, I decided to measure my needs and see what I really needed.

Guess what? None of our locos drew over 1.5 amps running. Most were under an amp. So, much less expensive and more available 6000 to 6800 mAh packs will give us over 4 hours continuous running on any of our locos.

The lesson to take away from this, is don't guess. Measure and calculate.



4. PebbleCreek Model Railroad Club's (earlier) battery car (UP stock) and LGB loco preparing for the Thanksgiving open house in 2016. Bruce Petrarca photo

Litchfield

STATION

Model Railroad Technologies Accutrack Speedometer 2

NCE
The Power of DCC

DiGifrax
Complete Train Control

Tsunami 2

LOKSOUND
SELECT

TRAIN CONTROL SYSTEMS

Wow!
Only \$64.95



- Click here to visit our website -

www.LitchfieldStation.com
623-298-7355



5. Charging a lithium pack on a nonflammable surface.
Bruce Petrarca photo

Charging

Poor quality cells or improperly charged lithium batteries can lead to explosions and fires. Remember the 2016 debacle with the Galaxy Note7 smart phone that cost Samsung billions of dollars? If you don't want something like that to happen in your loco, pay attention.

I follow a few simple rules:

- Buy the best quality cells or batteries.
- Make sure they have built-in protection boards.

Great control in a tiny package





- Touch Toggle™ plug in controls
- Bright clear indication
- Easy setup
- Flexible system

Stall Motors, Twin-coils, Power, and Servos

Now for Tam Valley Depot and MRservo too!

BERRETT HILL TRAINS



Made in the USA 

What will they think of next? www.berretthillshop.com

ADVERTISEMENT

ADVERTISEMENT

IOWA SCALED ENGINEERING

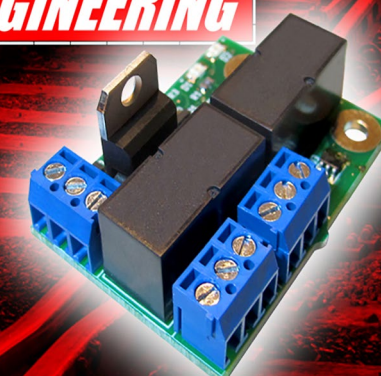

MRServo Slow Motion Turnout Controller

[LEARN MORE >](#)

TamValleyDepot.com



Frog Juicers

Automatic DCC polarity reversers for frogs on turnouts and crossings.

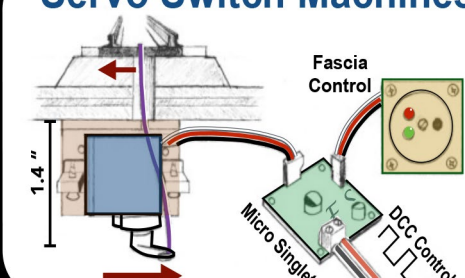

Servo Switch Machines

1.4" Fascia Control
Micro Singler
DCC Control

DCC IMPULSES | 11

- Charge them with an appropriate charger designed for lithium batteries.
- Don't charge any faster than ½C - this will mean a few hours to fully charge a depleted pack.
- Charge the battery on a nonflammable [5] surface (old floor tile works).
- Don't leave the battery unattended during a charge cycle. Don't mow the lawn or go to the grocery store.

I found a charger that I like. It is not inexpensive, but you may only need one. My friend is the **HiTEC multi charger X1AC plus** [6]. Wow, what a mouthful. I bought mine from Amazon

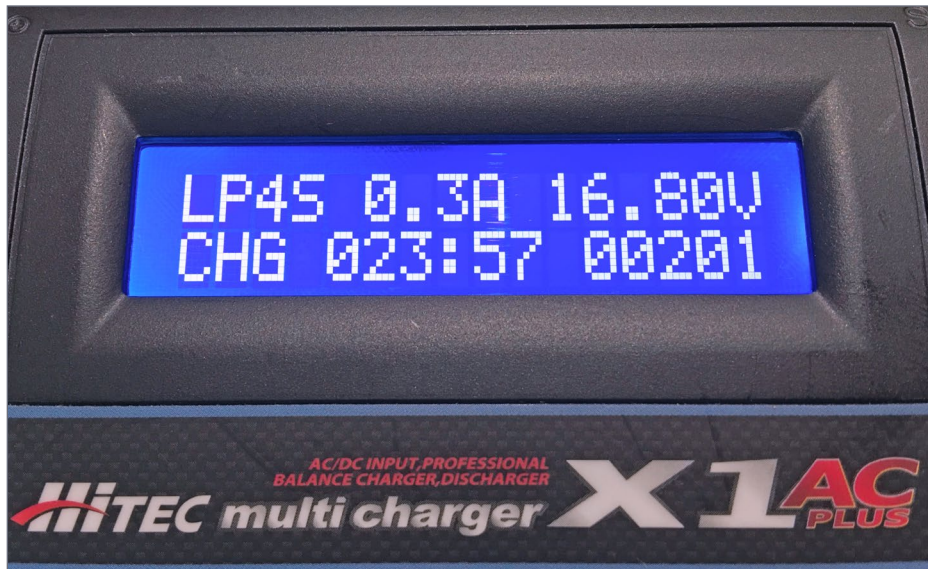

6. HiTEC multi charger X1AC+ topping off the charge in a pack. This display shows: Lithium ion 4 cells (LP45); charging at 0.3 A; with a battery voltage of 16.80 V; it has been charging (CHG) for 23 minutes and 57 seconds; 201 mAh have been added to the battery. *Bruce Petrarca photo*

DCC IMPULSES | 12

([amazon.com/dp/B005LH3392](https://www.amazon.com/dp/B005LH3392)). It will run on AC power mains (100 to 240 volts) or DC (car battery) and charge almost any battery you can throw at it. It MUST be adjusted for battery chemistry and number of cells and maximum charging current. However, once it is set (in my case Lithium ion, 4S, 3 A for the 6800 mAh garden battery packs), it is plug and play. Connect the battery to the charger; plug the charger in; press and hold the start button. After the system verifies that its settings match the pack connected, press the start button again.

The X1, as I call it, not only charges things well, but does a great job of letting you know what it is doing along the way [6]. Many chargers expect you to understand what they are doing by a few LEDs that blink or change color depending upon what the

ADVERTISEMENT

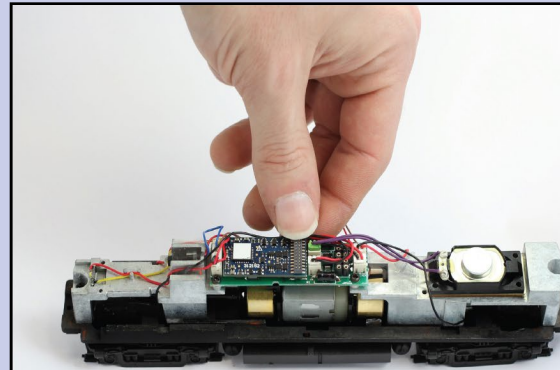

Easy Installation Amazing Sounds Tsunami2™

Tsunami2 21PNEM digital sound decoders simply plug into models that are equipped with a 21-pin connector. With this decoder, you can have your model running with our massive sound library and top-of-the-line motor control in as little as 5 minutes!

Compatible with Bowser, InterMountain, Atlas, Scale Trains, Rapido, Fox Valley Models, and other model manufacturers

SOUNDTRAXX™
www.soundtraxx.com

Click now to watch the full install!

Watch Now ▶

charger is doing. The engineer in me likes data better than blinking lights.

Another good charger is the Imax B6AC charger. I understand that it is available on Amazon and eBay. The menu is exactly the same as the X1. While I cannot comment on this product from personal experience, I have a high recommendation for it.

Between garden railroading and smaller scales, there are differing needs. The garden folks would like charging capabilities up to 5 amps. For the smaller scales, 200 mA (0.2 amps) is a very convenient and safe level. Both the X1 and the B6AC are adjustable from 0.1 amps to 3 amps.

You may have a preferred charger. Perhaps you'll share your find with other readers by clicking on the Reader Comments buttons at the beginning and end of the column.

Polarity

One issue in the garden that doesn't raise its head so high other places is battery polarity. Most garden installations have trailing battery cars. Some with the DCC receiver in the car, some with it in the loco.

There is a semi-standard created by Aristo-Craft's early entry into battery powered garden locos. They equipped many of their models with a battery connector [7]. Many modelers use these connectors on all their battery powered locos, regardless of manufacturer.

Unfortunately, not all folks who are putting these connectors on their locos use the same side for positive and negative. I recommend you choose to follow the Aristo-Craft standard (red and black [7]), or the opposite, and make all your locos the same. At the club, we started with the standard and will adjust future installations to comply.

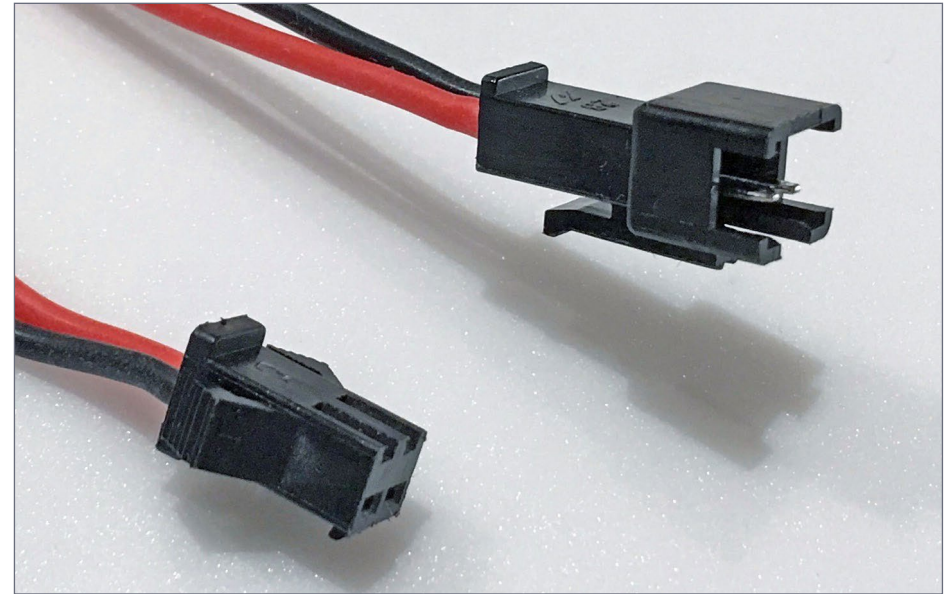

7. Aristo-Craft connectors, both battery (left) and loco (right) side. *Bruce Petrarca photo*

Sources

Where to get the batteries you need? Here are some sources I've found. Feel free to share yours with readers by clicking on the Reader Comment links at the beginning and end of the column.

For the garden, some folks want high speeds which translates into voltages around 20 volts. I haven't chased after these high values. They are available from garden railroad specialty retailers, such as Reindeer Pass (reindeerpass.com). Alas, we have no dedicated garden railroad retailers advertising in MRH.

However, I find that the 14.8 volt (4S) packs are just fine with any of the locos at our club or my layout. CVP sells, through their dealers (cvpusa.com/airwire_dealer.php) and directly on their web site, both 3400 mAh and 6800 mAh 14.8 volt packs. My

DCC IMPULSES | 15

only issue with this product is that it's polarity is reversed to the Aristo-Craft standard. However, with care, the pins can be slid out of the housing and reinserted in the opposite side. Be very careful not to short the two leads together in the process.

Quality packs in the smaller capacities are a bit harder to find.

Through the NMRA, I've come to know Pete Steinmetz. Pete was one of the co-founders of Dead Rail Society (deadrailsociety.com) and is currently the director of the San Diego division of the NMRA. He also has a business called Dead Rail Installs (deadrailinstalls.com), based in part on his prior career sourcing rechargeable batteries from around the world. A lot of what I've learned about present-day battery technology has come from Pete.

Pete has become my go-to guy for batteries (deadrailinstalls.com/battery-sizes-and-capacities). He stocks, or has available in a very few days, many sizes of the smaller batteries. Because of his prior work, he is fanatical about cell quality and protection. In addition, he is a dealer for CVP's AirWire, BlueRail Trains, SoundTraxx and Tam Valley Depot. Pete even makes kits for installations in what I call "mid-scale" locos, such as On30.

I realize this column is a snapshot of where I am in this process just now, aimed mostly at the garden. I'm planning some work in the smaller scales and hope to share that later this year.

Please share your experiences and ideas. Just click on the Reader Feedback icon at the beginning or the end of the column. While you are there, I encourage you to rate the column. "Awesome" is always appreciated. Thanks.

Until next month, I wish you green boards in all your endeavors. At that time, I'll discuss the battery cars I've been building for our PCMRC garden railroad with full-time voltage metering.



**Click here for
reader comments**

TONY'S TRAIN XCHANGE

Committed to your DCC support!

DCC Specialties Cross Hare!



Everything You Need To
Install Fully Automated
Crossing Gates or Signals!

Starting at \$69.95

Order Yours

Intermountain HO Paducah GP10



They're Finally Here!

ESU Dual Mode DCC/DC
Decoders On Board, Excellent
Detail, Multiple Lighting Effects,
12 Different Road Names!

Starting at \$149.95

Order Yours

NCE Power Cab & NCE USB



Pair Them For The Perfect
DCC and Programming System

See our website
for Tony's Low Price

Order Yours

**Do you need a Sound or
DCC Installation done?**

Get a quote!



Providing unmatched person to person
DCC support for more than 25 years, the
kind of service that has made us #1 in DCC.
DCC questions? CALL US! 1-800-978-3472

We'll get you on the right track!

April 2017



From first train set to railroad empire...

*Our complete line of DCC products
grows with you. Discover the fun!*

- Designed and manufactured in the U.S.A.
- Preferred for ease of use and ergonomic design
- Unlimited scalability for any size model railroad
- Plug-and-play means more time running trains
- Great customer service and excellent support



Visit our new and improved web site for all your DCC needs!

- Get the latest new product announcements
- Watch our detailed how-to videos
- Browse the all-new Information Station
- Enjoy secure online sales, day or night!



See your dealer

Visit ncedcc.com



The MRH Media family

**Model Railroad
Hobbyist magazine™**

mrhmag.com

store.mrhmag.com

**Model
Railroad
Hobbyist
Store**

Brought to
you by
MRH
MEDIA

trainmasters.tv



Shop the MRH Store ...

**Model Railroad
Hobbyist
Store**

Helping you achieve your model railroading dreams

Search

**Welcome to the
Model Railroad
Hobbyist
Store**

Problems with an order? Call 800-920-6020 for help during US business hours.
Or email store@mrhmag.com any time.

Select the category you want to browse:



Model Railroad Hobbyist | April 2017 | #86

GETTING REAL

column

JACK BURGESS



Click here to rate or
comment on this article

FINALLY GETTING IT RIGHT

IF YOU MODEL A POPULAR PROTOTYPE RAILROAD, such as the Southern Pacific Railroad or Pennsylvania Railroad, building models of their major structures such as stations and water tanks could be a relatively simple project given the variety of model structure kits currently available. If kits aren't available, scale plans and photos are most likely available for many of the standard structures.

Modeling a less popular railroad, such as my Yosemite Valley Railroad which didn't have such standardization, can be more challenging. Such was the case with the brick oil house in the Merced yards [1]. The oil house was used to store lubricants, flammable liquids, and such.

I didn't even know that the YV had an oil house until I obtained a complete copy of the *Liquidation Notice* issued by the railroad scrapper when the railroad was being dismantled in 1946. That *Liquidation Notice* listed the locomotives and freight cars for sale, as well as various buildings and machinery. [2] The listing for the oil house read simply "Oil House - 19'x25' Brick; Equipment." None of the published photos at that time included even a glimpse of a

► **MODELING REAL RAILROADS AND WHAT THEY DO**



1. Looking down the turntable lead late in the day. On the right are the Stores building, the breezeway, and the brick oil house. On the left is a portion of the Bunker C fuel oil settling tank and the gray-painted oil tank. In the background, one of the YV 2-6-0s is on the lead into the Paint House on the other side of the turntable.

OIL HOUSE

19'x25' Brick; Equipment

2. This portion of the Liquidation Notice issued when the YV was being scrapped listed just the basic dimensions of the brick building and the fact that it included some "equipment." How the scrapper expected to move a brick building if it was sold is unknown. It was eventually scrapped in place.

brick building in the Merced yards. My own collection of YV photos had grown to over to 500 or so by then but none included a hint of this elusive building.

Fortunately, many of the railfans from the 1930s and 1940s were still around in the late 1960s when I decided to model the YV, and I was able to visit several of them in Northern California and either purchase copies of their YV photos or even borrow their negatives and print my own copies of their photos. Ted Wurm was one of those in the latter group. While he had taken over 45 photos of the YV when it was in operation and shortly thereafter, he had never printed any of his negatives. While visiting Ted, he offered to lend me his negatives with the only condition being that I make him a print of each negative. What a deal!

My first effort

It was after I had finished making the prints of his negatives and was studying them that I noticed a brick building behind locomotive No. 28 in a photo Ted had taken in January 1937. [3] That brick building had to be the oil house since brick was a very unusual construction material in quake-prone California. It was on the lead track to the turntable, and the wood platform around the building on the track side was obvious, as were the corrugated roof and brick eave details. I felt at the time that my own collection of YV photos would not continue to grow much beyond its then-current size. Assuming I would never get another photo of the building, I used the size of the building and this one photo to draw up plans, and then started construction of a model of the building. When drawing my plans, I assumed that there would be a sliding door on the track side of the building (which was hidden by the locomotive) since I presumed there needed to be a way to directly load drums of lubricating oil from a box car into the building. I also assumed a person door would be on the wall facing the turntable to the left.

GETTING REAL | 4

Based on this limited information, I built my first (of three) versions of the building. [4] My plans and an article on building this version of the oil house were published in the February 1983 issue of *Railroad Model Craftsman*.

Fortunately, I was mistaken about the size of my YV photo collection. It continued to grow (now over 3,300 photos) and several years later I obtained two more photos of the oil house. [5-6] I was also able to obtain a *California Railroad Commission (CRC) Inventory* of the railroad that was prepared in 1917. This detailed report was developed to determine the cost of building the Yosemite Valley Railroad, since the original construction records had been destroyed in the 1906 San Francisco earthquake and fire. Shipping tariffs on the YV were required to be

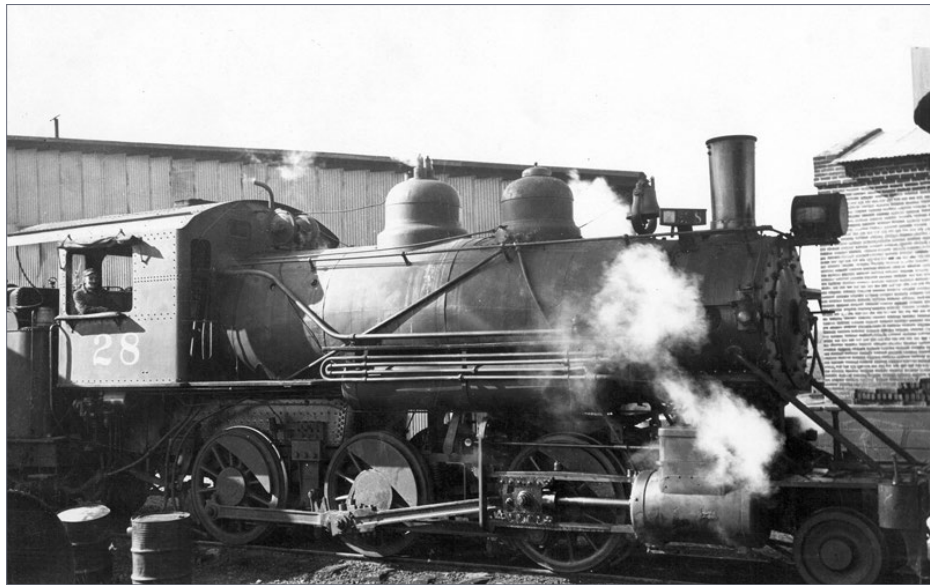

3. This was the first photo I obtained that showed even a portion of the brick oil house. The wood platform around the building and the corrugated roof and eave brick details are obvious in this photo. *Ted Wurm photo*

GETTING REAL | 5



4. My first effort at modeling the oil house in the YV Merced yards was based on the single photo I had, together with the dimensions from the *Liquidation Notice*. It was constructed of styrene with Holgate & Reynolds embossed brick styrene. But the sliding door on the long side of the building, as well as the door on the other side and the round vent, were later found to be incorrect.

based on the cost of original construction, and the CRC was thus obligated to quantify that cost in order to set shipping rates. While that abbreviated *Liquidation Notice* was valuable, this *Inventory* was even more detailed. Every piece of equipment, building, machine, and even grade crossing planks were measured, quantified, and the reproduction cost listed. The description of the building in the CRC report [7] includes many valuable details. But it also proved that my first rendition of this building had some significant errors, the major one being the wide sliding door on the side of the building facing the tracks. Instead, the building had a single 5'x6' iron-shuttered window and a 5'x7'6" door.



5. This photo was taken as the YV Merced yards were being scrapped, but it provides a fairly good view of the side of the oil house that faced the turntable in the foreground.



6. This photo was also taken during scrapping of the railroad. The steam crane is on a track parallel to the turntable lead and the corrugated building to the left is the sand house. This view of the oil house clearly shows both the wall toward the turntable and the blank wall along the turntable lead. *Al Rose photo*

Merced	Brick Oil House 19'9"x25'5"	Excavation and foundation 41,593 cu. yds.	11.90	494.96	
	on conc. found., floor 4" conc.	Common brick - 19, M.	20.00	380.00	
	Roof galv. iron on 10-2"x2"	Structural steel- 3200#	.05	160.00	
	LS on 10-8" I-beams. Bldg.	Corrugated iron- 4,86 sqs.	9.00	45.55	
	has 1-5'x6' wdw. with iron	Flooring- cement 414 sq. ft.	.15	62.10	
	shutters & 1- 5'x7'6" dbl.				
	door. Massive found. of				
	concrete, extending 6' above				
	ground and carrying brick				
	walls of building.				
		Total	1907.86	1140.71	991.01

Note—Show cost in as much detail as possible

7. This description of the oil house from the 1917 (CRC) *Inventory* reads "Brick Oil House 19' 9" x 25' 3" on conc. found. [foundation], floor 4" conc. Roof galv. iron on 10-2"x2" LS on 10-8" I-beams. Bldg. has 1-5'x6' wdw. [window] with iron shutters & 1-5'x7' 6" dbl. [double] door. Massive found. [foundation] of concrete, extending 6' above ground and carrying brick walls of building."

Use our custom
Google search on the
MRH website to find
topics of interest

CLICK TO FIND OUT MORE

My second effort

I drew up new plans for the building based on these new photos and the CRC report, putting the window on the side of the building facing the turntable (as shown in the photos) and moving the door to the side opposite the tracks.

Like my earlier version, this model was built with sheet styrene faced with Holgate Reynolds embossed brick styrene. [8] I used this technique on both of my models and treated the embossed brick styrene with a method Noel Holley described in an article in



8. My second attempt at building the oil house in the Merced yards. This is the side toward the turntable.

Did you see this MRH video?



The ultimate “Yes, it’s a model” video as James McNab switches NW 86th

[Watch the video now](#)

Get the latest Model Railroading News, Tips, Reviews & Opinions



Our iTunes feed has changed search for “Mike And Scotty Live” to receive the latest episodes!

www.themodelrailroadpodcast.com

Hosts:
Scott Mason: www.scottymason.com
Mike Rose: www.mrhobby.com

Don't Miss our Monthly Interviews
& Product Announcements

RMC in the mid-1970s. It involved brushing a coat of water on the painted plastic brick surface and then brushing on a layer of dry plaster of Paris. Once dry, the plaster was brushed off of the surface of the bricks, leaving just the suggestion of mortar between the bricks. But I never felt that my efforts on either building were very successful but accepted them as “good enough.”

Once it was completed, I installed the finished building on my layout. By 2011, I had built all the structures needed for my layout, had installed all the details needed, completed all the scenery, and declared that my layout was “finished.”

More information

There are over 100 structures on my layout, all scratchbuilt. I have drawn plans for all of these buildings using CAD (computer-aided design) software and I sell CDs of these plans on my website (yosemitevalleyrr.com). A few years ago, another YV modeler/friend bought the CDs and started building a mockup of the oil house from my plans to determine if he would have room for it on his layout. But after studying his mockup and a mockup of the adjacent Stores building, he thought something was wrong and emailed me about his concerns. I eventually agreed that he was correct.

The oil house was a simple design with peaked ends. The logical approach when designing a rectangular building with peaked ends is to have those peaks on the shorter sides of the structure. That reduces costs for building the walls and generally is the most economical design.

By now I had several other photos in my collection which showed at least a portion of the building. An exchange of emails over the next couple of months included reviewing a Sanborn map [9] I had of the buildings in the YV yards. This Sanborn map showed both the oil house and the adjacent Stores building (identified

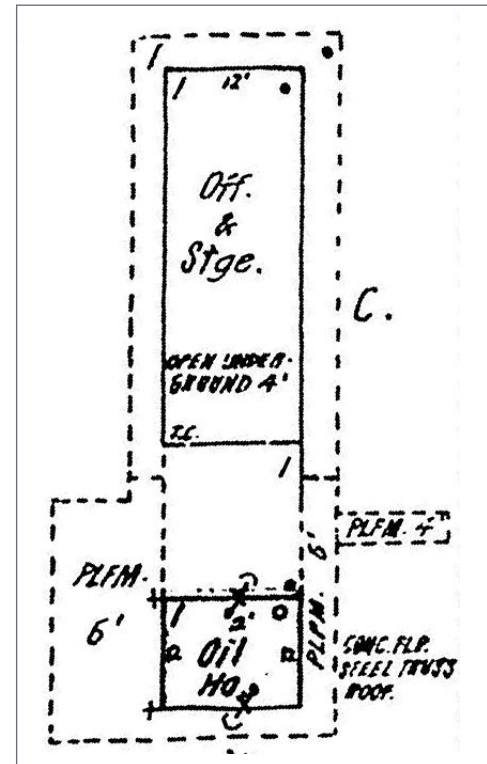

9. This portion of the Sanborn map for Merced proved that the longer wall faced the turntable (toward the bottom on the map). The space between the oil house and the Stores Building was covered by a breezeway.

as “Off. and Stge.” or “Office and Storage”). It was obvious from this map that the side of the building facing the tracks was the “short” side and the peaked ends were on the longer side facing the turntable. That meant that both my model and drawing were incorrect.

A Sanborn map legend [10] also showed that the door was on the side facing the Stores building and the shuttered window was on the opposite side facing the turntable. A 6-foot-wide platform surrounded the Stores building and the track side of the oil house. A 4-foot-wide walkway extended out to the adjacent turntable lead track. I’m not sure why the platform on the other side of the building was also shown as 6 feet wide since it was drawn larger.

GETTING REAL | 11

Based on this new information, I redrew my plans for this building. I first swapped the orientation of peaked ends and other sides, then continued to make other changes and refinements. I had been able to measure the Stores building in the early 1980s before it was burned, so I used historic photos which showed both buildings to determine the height of the oil house compared to the Stores building. A photo [11-12] clearly shows the I-beam rafters listed in the *Inventory* which I had previously ignored. The size of the window on my original drawing (based on the *Inventory*) seemed too small compared to a photo of that side of the building. [6] But a very early photo proved that the measurements in the *Inventory* were for the actual window and not the iron shutters that covered the window. With that final question answered, I finalized my drawings and realized that I would need to build another, and hopefully a final, model of the oil house for my layout.

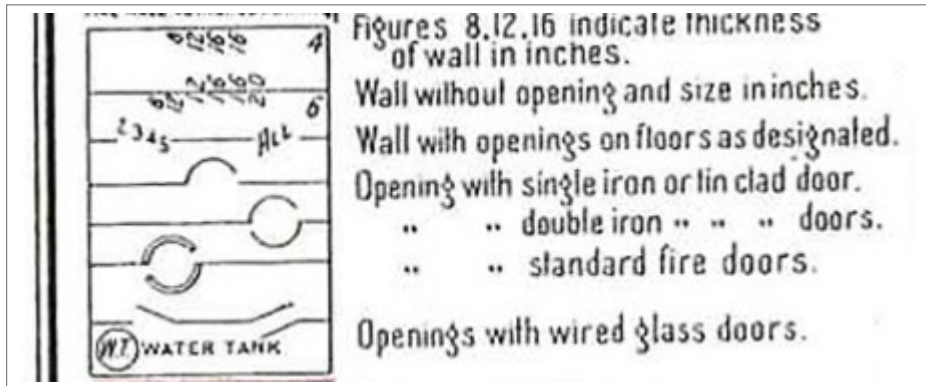

10. The Sanborn map legend shows the door symbol as a half-circle (listed as “Opening with single iron or tin clad door”) and that it was on the side of the building toward the breezeway and adjacent Stores Building.

GETTING REAL | 12

My final effort

The embossed brick styrene I used on my first two models of the oil house was no longer available, which led me to think how I might build this new version. About this time I also started thinking that this relatively simple structure might make a good “kit” for other YV modelers too. I like to encourage model building through articles and clinic presentations, since I feel that we get personal satisfaction from a hobby only if we continually work at it, whether laying track, constructing scenery, building freight cars or structures, or holding operating sessions.

So I asked those on our YVRR Yahoo chat list if they might be interested in buying a kit for this oil house. A dozen modelers responded in the positive so I started work on “producing” a

ADVERTISEMENT

Floquil/PollyScale stash running out?
MRH has mapped the old familiar colors to new readily-available acrylic paints.



Floquil / PollyScale Color Name	Color Number	Model Master	Valley	Minicolor	Model Color	Color Name
Primer Grey	MRH 4043	YVA F1000	16-01			
Engine Black	MRH 4055	ML 2000 YVA F101	16-01			
Steam Engine Black	MRH 4056	YVA F1007	16-01B			
Oil Black	MRH 4057	YVA F1021	16-007			
Weathered (Charcoal) Black	MRH 4020	ML 2002 YVA F1004	16-02			
Redder Grey	MRH 4057 MRH 4211	YVA F1044	16-04			
Redder White	MRH 4012	ML 2004 YVA F1001	16-02			
Going Black	MRH 4017	ML 2002 YVA F1003	16-02			
Colored Red	MRH 4017 MRH 4211	ML ... YVA F1002	16-02			

Floquil / PollyScale Color Name	Color Number	Model Master	Valley	Minicolor	Model Color	Color Name
Tan	MRH 4057	YVA F1006	16-01			
Redder Orange	MRH 4057	YVA F1003	16-01B			
Redder Yellow	MRH 4019	YVA F1016	16-01			
Redder Brown	MRH 4024	ML 2009 YVA F1049	16-01B			
Redder Tan	MRH 4025	ML 2009 YVA F1019	16-01B			
Red	MRH 4027	ML 2002 YVA F1020	16-01			
Red	MRH 4015	ML 2005 YVA F1007	16-01			
Concrete	MRH 4016	ML 2007 YVA F1012	16-01			
Agged Concrete	MRH 4016	ML 2007 YVA F1012	16-01			

Get your copy today! >>>

GETTING REAL | 13

total of 13 kits. While it involved a little more effort on my part, it more importantly opened the door to using more high-tech approaches on the project.

I chose to cut the roofs, plain sides, and platform support structures from 1/8" birch plywood on my miniature table saw. I also decided to have the peaked walls and some brick relief details laser cut from 1/8" material by Monster Modelworks (which does custom laser-cutting). Since correct doors and windows were not available, I drew them in SketchUp and had them 3D-printed by Shapeways.

Assembly of the "kit" went fairly quickly, especially with the laser-cut building sides and details. [13-14] I had already decided

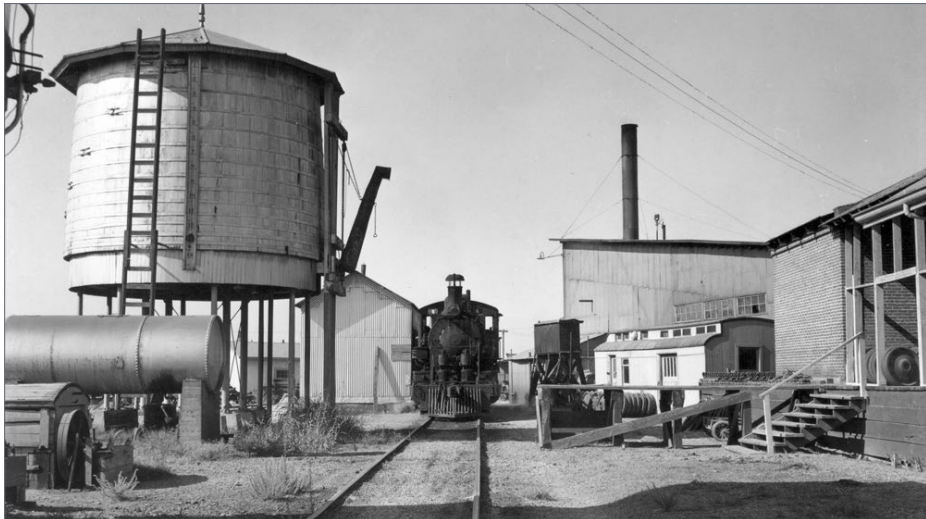

11. This photo is one of my favorites and looks down the turntable lead toward the roundhouse, basically the same view as the photo 1, but taken closer to the oil house. The brick oil house is on the right, with the walkway leading to the tracks as well as the breezeway between the oil house and the Stores building which is out of view on the right. *Al Rose photo*

GETTING REAL | 14

to use paper brick material to cover the model. I'd used printed brick paper from Paper Creek on a couple of other models, but they were no longer in business. There are other firms selling brick paper, but their offerings didn't include bricks with as many varied colors as shown in a color photo of the yard during scrapping taken by Al Rose. [15]



12. A close-up of the previous photo clearly shows the 8"-tall I-beams mentioned in the 1917 Inventory as well as the brick relief on this side of the building. The 2x4 wall construction of the adjacent breezeway is also visible. *Al Rose photo*

GETTING REAL | 15

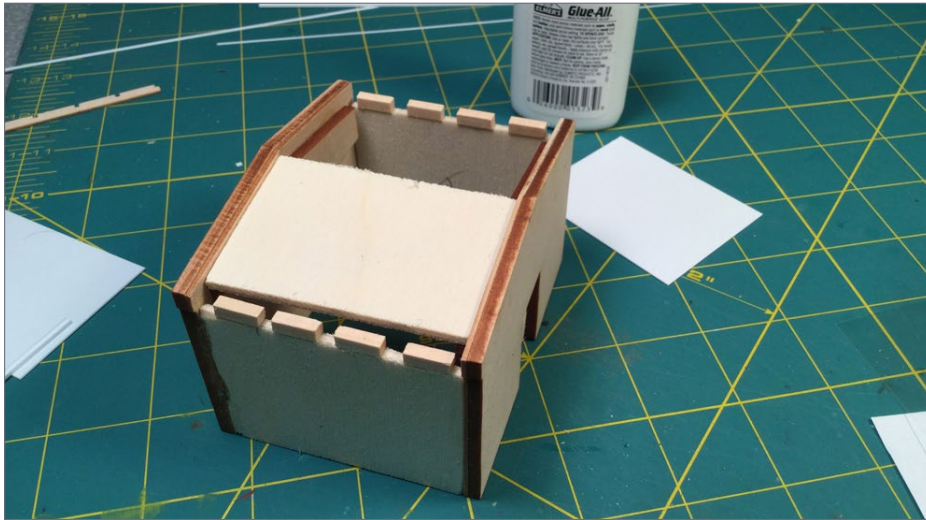

13. My third model of the oil house under construction. The basic “box” is 1/8” birch plywood. The laser-cut sides produced by Monster Modelworks include cut-outs for the I-beam roof supports.

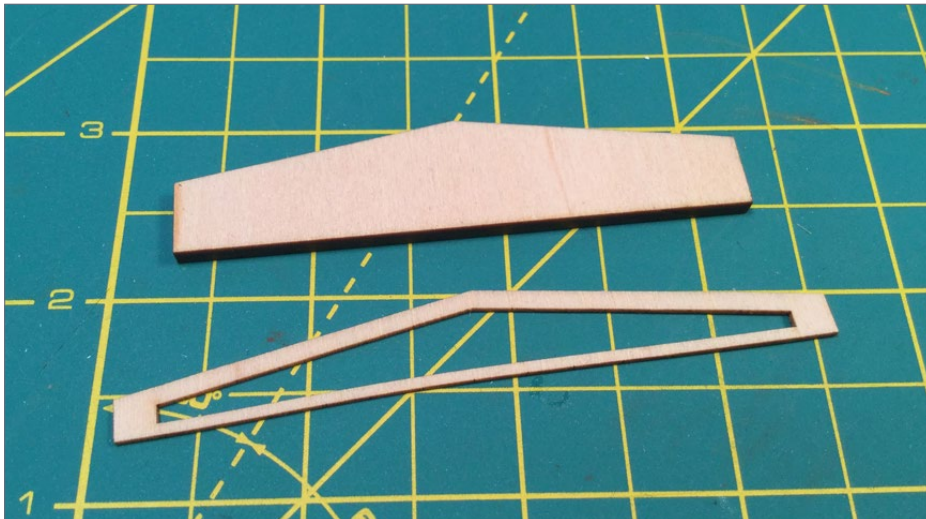

14. Two of the laser-cut parts that duplicate the brick relief on the ends of the building.

GETTING REAL | 16

Using Google Images, I found a straight-on photo of a real brick wall with the color variations I wanted. While it was a high resolution image, it wasn't very large. But I was able to use Photoshop Elements to “cut and paste” enough copies of the wall together to finally produce an 8-1/2” by 11” wide sheet of brick paper. [16]

I used Campbell's corrugated aluminum for the roof that I bonded to the styrene sub-roof with Bron industrial-strength double-sided tape (called Bron Killer Red, brontapes.com/product/bt-3854-original-killer-red). When I first learned of this tape, the minimum order from the factory (the only option) was \$100. But it was easy to find 10 modelers who also wanted to join in on



15. Al Rose stood on a locomotive to take this photo of the yards in 1946 as the railroad was being scrapped. A portion of the oil house is partly visible beyond the nearly demolished roundhouse. The shuttered window is painted black, and the brick colors are somewhat subdued. *Al Rose photo*

GETTING REAL | 17

a group purchase. (As modelers in our area heard about this tape and tried it, we ended up putting together three group orders.) This tape is extremely strong and has many uses. Tap Plastics sells what I think is the same tape (online only) which they call “Clear Double-Sided Permanent Bond Tape.”

Rather than airbrush the corrugated roof with a light gray as Campbell suggests, I first applied several light coats of Dullcoat. A light overspray of a gray can then be added to provide some color variations, although I usually skip that step and provide the color variations using pastel chalks. I think that the resulting color is more representative of actual corrugated iron.

Additional photos added to my collection after my second effort at building the oil house showed a “breezeway” between the building and the adjacent Stores building. [17] As part of my second building effort, I somewhat replicated this structure using strip styrene. For this, my last effort, I drew the simple structure in SketchUp and had it 3D-printed. Not only was this effort less time-consuming, it was also more accurate.

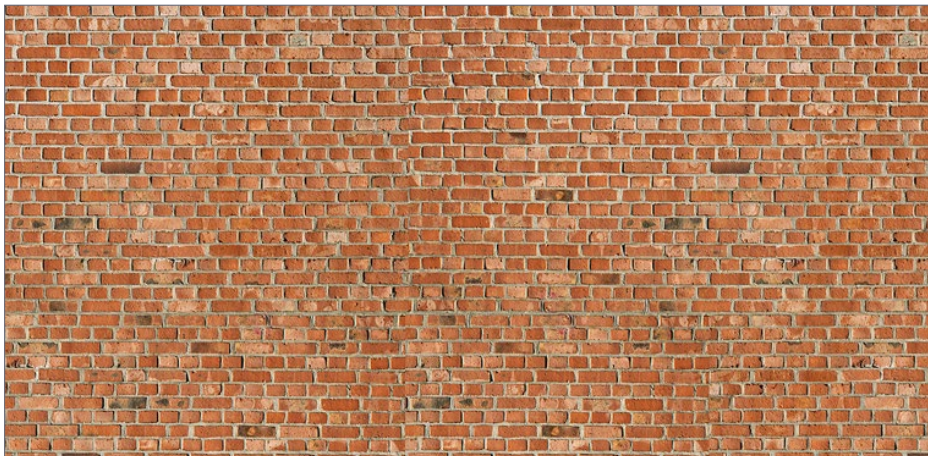

16. A portion of the 8-1/2” by 11” wide sheet of brick paper I created from a single Google image of a real brick wall.

GETTING REAL | 18



17. This photo shows the breezeway between the brick oil house on the left and the Stores building on the right. Locomotive 22 is on a track parallel to the turntable lead where the two buildings were located. *Charles Givens photo*

With construction complete, the oil house and breezeway were installed on the layout. [18] The Al Rose photo [11] shows some wheels in the breezeway, along with what might be brake shoes on the outside platform. I duplicated the wheels with Tichy items and the brake shoes with some brass castings from Precision Scale. Hopefully, another photo will not turn up that exposes errors in this third attempt, but I am very comfortable that I got the details correct this time.

Conclusions

No, I won't be going into the “kit business,” and no more of these “kits” are available. However, putting together kits for a dozen

GETTING REAL | 19

YV fans, some of whom I have known for years and others who I met online, was very satisfying and part of the “giving back to the hobby” I like doing.

I would guess that very few modelers actually need to build a similar railroad prototype structure that isn't already available as a kit. But what if you need to build a row of six or eight company houses and nothing close is available? You could approach that project as a bunch of custom kits which might help automate the process. What if you have all of the building sides custom

GETTING REAL | 20

laser-cut? Instead of compromising on the windows you need by just using the closest available styrene castings, you could draw up those windows and have the 30-40 windows you need 3D-printed, possibly cheaper than buying those “close enough” commercial ones. Or what if you know a couple of friends who model the same prototype as you do, and you all need to build the same structure? Maybe the kit approach would not only be cheaper and easier, but would let each of you check that structure off of your bucket list.

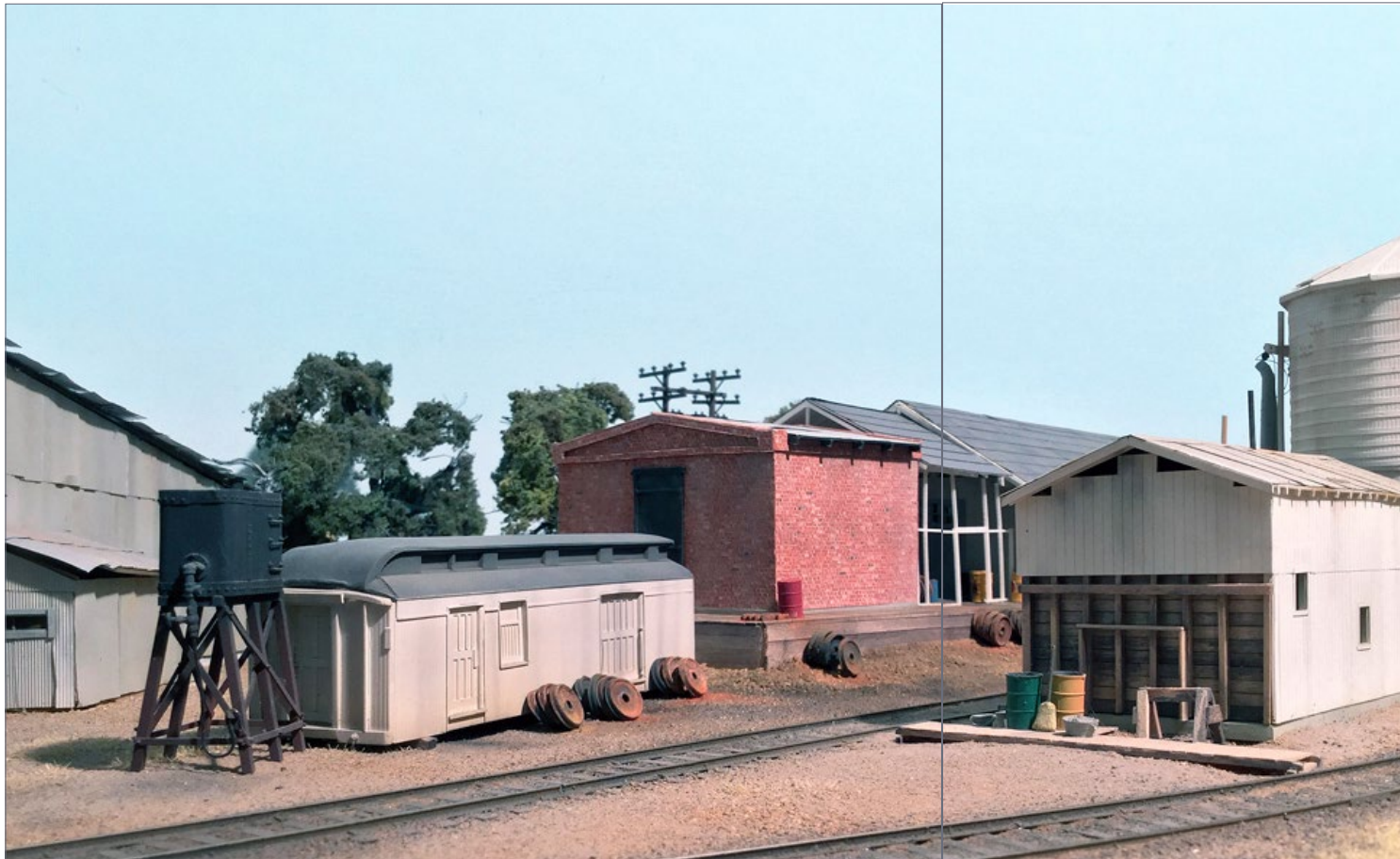

18. The view of my completed, and hopefully the last, model of the oil house. This is the end of the building that faces the turntable (out of view to the left) with the window with the iron shutters. The building next to the oil house is a tool shed built out of the remains of combination car 105 after it was partially burned in 1937. On the other side of the turntable lead are the sand house and the 25,000-gallon water tank. The wheels propped up against the tool shed and the platform around the oil house are based on the prototype photos.



[Click here for reader comments](#)

FAST TRACKS BUYS MT. ALBERT SCALE LUMBER CO.

Fast Tracks is helping the world build EVEN better railroads with the addition of Mt. Albert Scale Lumber.

New Mt. Albert products and model kits coming soon.

FAST TRACKS
MT. ALBERT

SCALE LUMBER CO.

Easy ordering • Live online support
Earn Waypoints with every purchase

shop online 24/7

handlaidtrack.com

1-888-252-3895

service@fast-tracks.net

MRHMAG.COM



KEN PATTERSON

Model Railroad Hobbyist | April 2017 | #86

WHAT'S NEAT WITH KEN PATTERSON

column



Click here to rate or
comment on this article

KEEPING IT ALL TOGETHER: GLUES AND SCREWS FOR FOAM-BASED LAYOUT CONSTRUCTION, TSUNAMI2 EXHAUST PROGRAMMING, AND MORE ...

THIS MONTH WE EXPERIMENT WITH VARIOUS glues and screws for an addition for a runaround siding track to my home layout. We also build a wood railroad crossing and its surrounding scenery to make a pretty interesting layout construction segment this month.

For DCC this month we talk about programming Tsunami2 Dynamic Digital Exhaust (DDE) from Soundtraxx. I filmed and edited a video on the subject. You will see every step in the process as I make it easy to understand.

We end this month's video with an Athearn trade show video that took four years to make. It includes over 100 modeled photo set-ups along with 50+ video clips of very carefully modeled runby scenes in HO scale.

► PHOTOS AND VIDEO OF SUPERB MODELS

• INDEX

• TABLE OF CONTENTS

Layout construction



1. (Above) For this month's layout construction segment, I wanted to add space to my layout for a runaround track where I could place trains on the layout near the storage drawers that sit under the layout. I avoided this project for about six months simply because I did not know of a way to glue foam to the edge of my layout, and have it hang over and be strong. I need a set-up that is unbreakable when I carry the module outdoors for photo shoots.

2. (Top right) The plan was to figure a way to glue two sections of foam together, straight on with a butt joint, and see if the glue would hold. Would you build a craftsman structure over a glued base like this, and depend on the joint to hold?



[Click here to rate or comment on this article](#)



April 2017 -
What's neat ...

Playback problems? [Click here ...](#)

WHAT'S NEAT | 4



3. To test the idea, I glued two sections of 2-inch pink foam together with the Great Stuff Foam Pro we always use on the show, and weighted the assembly down to cure.

WHAT'S NEAT | 5



5. Six hours later I came back to test the glued sections of foam. I set up the glued panels between two paint cans and tested each glue joint by dropping a 15-pound dumbbell weight on the foam from a height of about two inches. Both glues held up to this abuse.



4. I also glued two sections of foam together with Gorilla Glue and water, setting this aside under weights to cure and expand to fill imperfections in the foam to create a tight joint.



[Click here to rate or comment on this article](#)



6. I then tested the Gorilla Glue joint by setting a 30-pound dumbbell on the bridged foam. This held, to my total surprise. No cracks, just a little bend in the glued foam section.



7. I wanted to break the glue joints to understand the strength and pressure required. so I placed the Foam Pro section on top of a dumbbell and pushed the sides down, breaking the glued joint fairly easily.

**Want to help keep
MRH free?
Then *click* on ads!**

 [Click here to rate or comment on this article](#)

WHAT'S NEAT | 8



8. The Gorilla Glue joint was much harder to break. I am sure it took more load to break than a modular layout would ever see, making this Gorilla Glue a sure bet to allow me to move forward with this project.



Click here to rate or comment on this article

Have you seen this?



click to play video

CHECK IT OUT!

kenpatterson.com

click here to ...

Visit Ken's website

Ken Patterson reveals his modeling secrets on video!



9. The next hurdle to figure out was how to control the Gorilla Glue's expansion as it cured, without the new foam being pushed away from the layout and leaving a gap. I thought about using 2x4 studs at an angle against the foam, or using bar clamps to clamp the foam in place. 2x4s would add too much weight to the cantilevered scene, and bar clamps would require removing the modules from the wall. I cannot do this yet as the final rail cuts between modules will not be made until all the track and wiring in the scene is complete. So, I thought of using wood screws to hold things in place until the glue cures.



10. I tested a section using one 2.5-inch-long wood screw to hold the Gorilla Glue joint together.

Please tell your buddies about MRH!

WE RELY ON WORD-OF-MOUTH TO GROW AND A BIGGER CIRCULATION MEANS MRH IS MORE LIKELY TO STICK AROUND FOR A LONG TIME TO COME!

WHAT'S NEAT | 11



11. After 15 minutes, this joint shows signs of failure as the glue pushes the two foam sections apart.



12. After thinking about it overnight, I picked up some 4-inch wood screws with large half-inch round pan heads. Using these larger screws, I repeated the experiment of gluing two sections of foam together using Gorilla Glue. After 30 minutes, the glue was hard with no visible expansion between the foam sections. I now had a good way to clamp/screw the foam in place while the glue cures and expands.

WHAT'S NEAT | 12



13. Measuring 6 inches wide, I cut a few sections of foam. These will create a 10-foot-long by 4-inch addition for the layout. I cut this with a thin Chinese style pull saw for a clean cut.

 [Click here to rate or comment on this article](#)

WHAT'S NEAT | 13



14. I attached a saw blade to my oscillating sander to cut the plywood fascia. The new foam will intersect the plywood at an angle. No other type of saw on the planet, that I am aware of, could make this cut without removing the module or cutting into the table-top benchwork. I am always finding new uses for this oscillating tool. It worked well and I did not have to remove the module. Note, I am using a steel ruler to protect the table's top from the saw blade.



[Click here to rate or comment on this article](#)

WHAT'S NEAT | 14



15. I used a pizza cutter to roll plastic under the layout to protect the top and sides of the layout table from the glue and water drips that are sure to follow in the next steps.

TrainMasters TV is part of the MRH product family.

TMTV members not only get great network TV level videos, they help pay for MRH and keep it free ...

WHAT'S NEAT | 15



16. I sprayed water on the sides of my layout and on the first layer of foam. I had to cut a hole in this foam section and the next to run block wires for the engine house. I then applied an even layer of Gorilla Glue to this and used the 4-inch screws to locate and clamp this foam section to the side of the layout.



17. I used about 20 screws to hold the foam strips in place as the glue expanded and cured. It usually takes 30 minutes for the expansion to stop and the glue to harden. The screws held tight and you could hear the glue bubbling and pushing up through the joint.

WHAT'S NEAT | 16

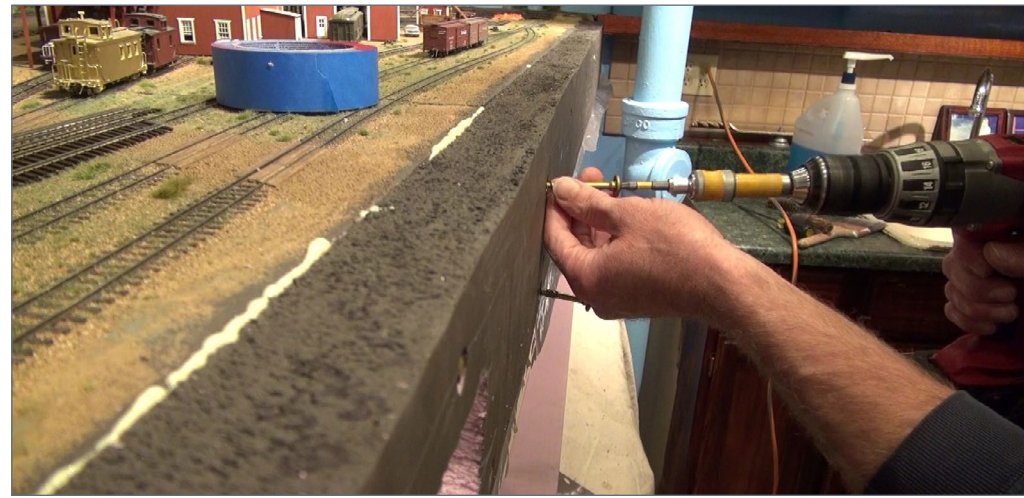

18. You can see how the glue squeezed up through the foam joint. This expansion fills any gaps between the foam panels, ensuring a solid, hard, strong bond. It is simply amazing glue. With the glue set, I removed the screws to use them on the next section.

**Did you know
there's an
MRH index
available?**

[CLICK TO FIND OUT MORE](#)



19. (Above) I immediately started on the second 2-inch foam layer, wetting this and applying a liberal coat of Gorilla Glue to the foam section.

20. (Top right) Securing the foam in place with 18 4-inch wood screws, I worked quickly until I had the whole section attached, overhanging the side of the benchwork by 4 inches. The glue and water drips onto the plastic protecting the finished wood work. I use drop cloths to protect the carpet and bookshelves under the layout. This process is very messy.

21. (Bottom right) I used a Stanley Surform to smooth the top scenery where the track and service road will be placed. I sealed this area with brown latex paint. When carving contours, it's easier to clearly see the topography with the brown paint, as opposed to looking into the glare of the pink foam.



WHAT'S NEAT | 19



22. (Above) Now I could figure out how the track would lay and flow through this area, bridging from the wall above the sink through a 26-inch radius/transition curve onto the module, allowing space for an access road running along the track.

23: (Top right) After soldering the track together and rolling a few freight cars through the scene. it was apparent that my track leaned a little. I corrected this with a 17-inch-long Auto body sander with 36 grit sand paper. To smooth the area where the track transitions down from the main line grade and back up again to meet the mainline at a switch 14 feet further along.

24. (Bottom right) With everything carved and smoothed I sealed the area with more brown latex paint and proceeded to glue the track in place with Liquid Nails spread by a putty knife.

WHAT'S NEAT | 20



WHAT'S NEAT | 21



25. I built a railroad crossing for a service access road by filling the track area with a lot of wood glue. Now, I know this looks like a mess but it will make sense in the next step.

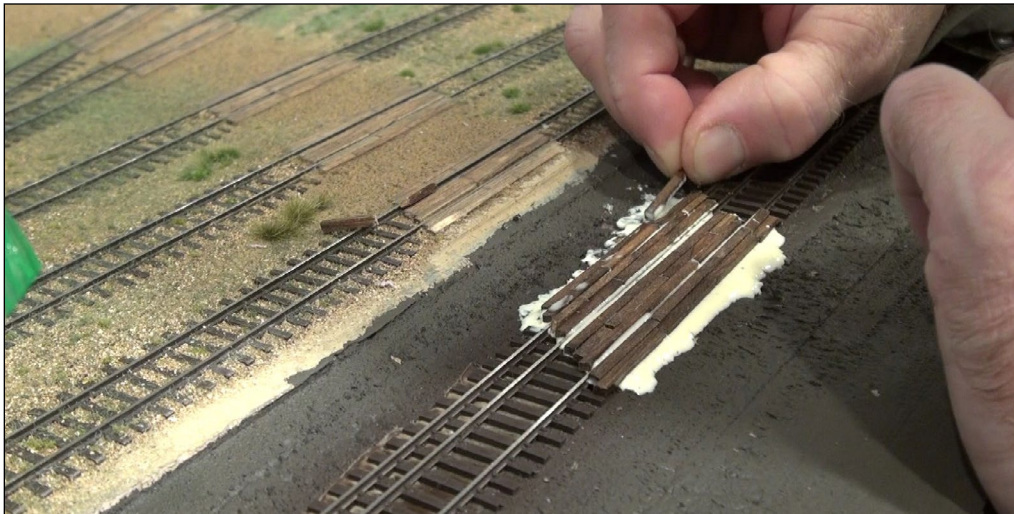

26. I then placed HO scale wood railroad ties into this glue, forming the crossing surface. I let this dry for about four hours.

WHAT'S NEAT | 22



27. I used my oscillating sander to sand flat the tops of the railroad ties that form our crossing, stopping when I reached the top of the rails. I used to do this by hand with a wood block and sandpaper but the oscillating sander speeds up this process.

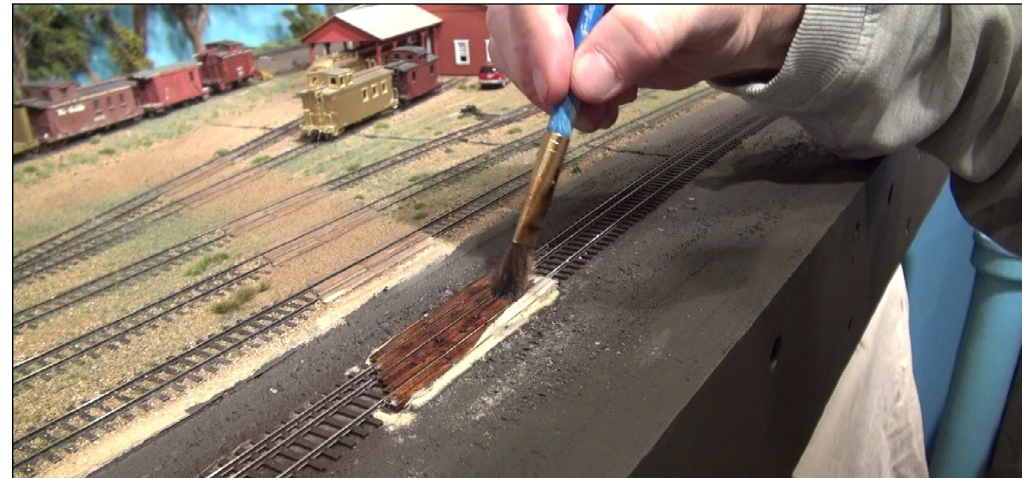

28. I stained the wood crossing with dark wood stain. When this is dry, the dirt added to the road area will weather the wood crossing to blend the scene.

WHAT'S NEAT | 23



29. (Above) While the wood stain dried, I built and stained the benchwork supporting the 26-inch radius approach track. It's more like a small shelf with a protective wood trim edge, from the wall over the sink. This is stained and polyurethaned to match the color scheme in my layout room.

30. (Top right) I ballasted the scene with creek rock sifted through a screen. The road was made from simple sifted dirt. Woodland Scenics ground foam was also added to the scene. The ballast and dirt are worked into the track and the surrounding scene with artists fan brushes.

31. (Bottom right) I glued the dirt and ballast with Woodland Scenics Scenic Cement, using cardboard to protect the finished areas from the glue until everything was soaked.

WHAT'S NEAT | 24



WHAT'S NEAT | 25

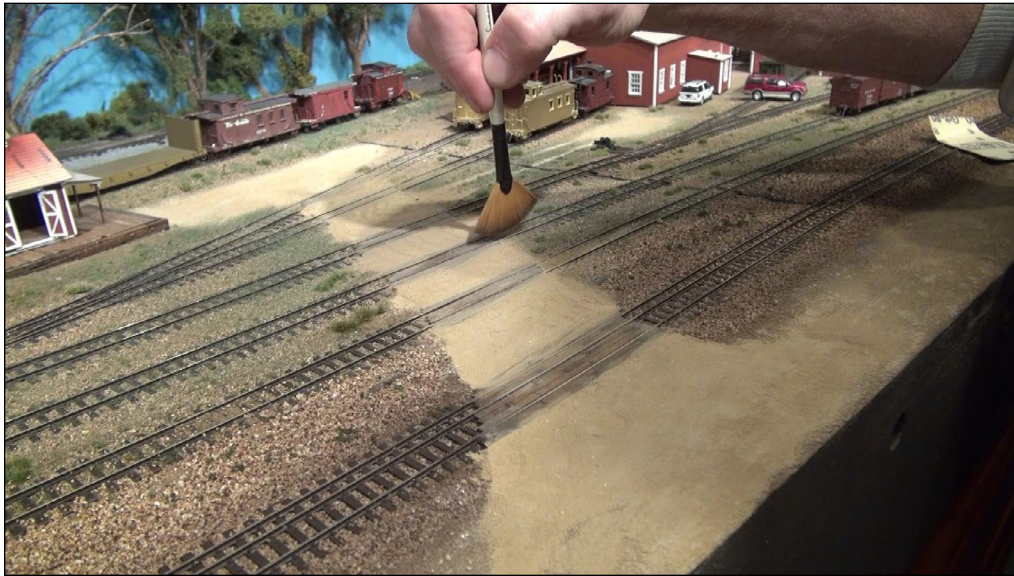

32. (Above) After the glue dried, I finished the service road with a raised even coat of dirt brushed into position between the wood crossings with artist brushes. This too was soaked with a spray of scenic cement.

33. (Top right) I let the scenic cement dry overnight, then I cut the grooves on the wood crossing ties for wheel flange clearance, using a 6-inch hacksaw blade. The hack saw blade is just the right width for performing this task on wood-planked surfaces around track.

34. (Bottom right) After planting a few Silflor weeds, adding a plywood fascia and finishing a new background hill with trees, this area of the layout is ready to use. Now I have a run around track which adds a 14-foot-long siding to the layout. I can now place freight cars onto the layout easily, from my storage drawers located underneath. It went together smoothly and adds more operating potential.

WHAT'S NEAT | 26



Soundtraxx Dynamic Digital Exhaust



35. This month we look at the Soundtraxx Tsunami 2 diesel decoder and study the Dynamic Digital Exhaust and how to program it to display your locomotive's specific running characteristics. It will then be able to produce sound in sync with various grades the model may encounter, or vary the sound effects when pulling a light train or heavy consist of cars through the hills on your right of way, all automatically. I use my Digitrax system to set the DDE programming CV's while the model is moving, so the decoder can sense the load on the motor in real time.

In the original Soundtraxx Tsunami decoders, you will recall we used CV's 177-188 to program the DDE. In Tsunami 2 we program the decoder in a different manner. We use what the NMRA refers to – in their standards adopted more than 25 years ago, as the page 2 level (2.xxx) of CV's. In Tsunami2 we get to this paged or "Two dot" level by setting CV 32 to 2. Now we can program the DDE by setting CVs 2.503 and 2.504



36. First, we set CV 2.503 while the model is running on the layout in speed step 1 on the DCC throttle. While the model is moving, program the CV to around 255.



[Click here to rate or comment on this article](#)



37. The next step is to set CV 2.504 while the model is moving in speed step 30. This process lets the decoder draw a graph in its internal memory, understanding the gear drag and pull weight of the locomotive when running light. This will allow the decoder to differentiate and understand when it is running light or heavily loaded, changing the tone and performance of the sound effects to match what the locomotive is doing.

You can further adjust the sensitivity of the DDE, i.e. – how sensitive the decoder is to changes in its running load on the motor – by setting CV 2.512 to say 35. You can play with these numbers to see how the locomotive performs on your layout and adjust the CVs to your taste.

To get further realistic performance while starting and stopping, adjust CV's 3 and 4 to add a little or a lot of momentum to your train. I like to set CV 3 to 75 and CV 4 to 150 when switching cars and using F11 to brake the train with full braking sound effects. In this month's video, I show the process and explained in about four easy-to-understand minutes.

Athearn trade show eye candy

To end this month's What's Neat video, I'm sharing an Athearn video I put together a few months ago to run as a trade show loop in the Athearn booth. The photos and video runbys that run in this month's video were shot over a four-year span. It is packed full of scenes shot both indoors, and outdoors in real sunlight, with close attention paid to all the details in each scene. Some four-second clips took a full day to set up and shoot. Some still photo scenes took 10 days to build and shoot. They add up to what I believe is a total modeling eye candy in HO and N scales. Pour a hot cup of tea and prepare to be entertained.

View more photos on the following pages ...



38. Somewhere out west on Southern Pacific tracks we find these beautiful Amtrak units being inspected for their continuing journey.

ARE ZERO DERAILMENTS POSSIBLE? YES! First trackwork, then rolling stock.

Make it run like a

Dream VOLUME 2 ... ROLLING STOCK BOOK

100 pages (est.)

By Joe Fugate

Pre-Order NOW!

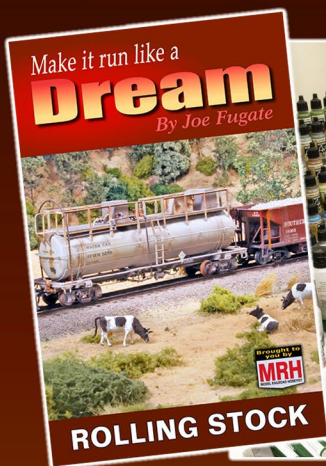

Sneak peek 2 coming soon!

Expected release date: June 2017

Click me to
PREORDER eBook >>
\$11.49

Preorder and get regular sneak peeks plus bonus materials

Click me to
PREORDER PAPERBACK >>
\$27.49 + S&H

Paperback preorder includes regular sneak peeks plus bonus materials too!

~~\$29.99~~

\$27.49

+ S&H
Paperback

~~\$12.99~~

\$11.49

eBook

Chapters include ...

- Refining the dream
- Setting appropriate standards
- Make a conformance test track
- Wheelset and truck issues
- Coupler issues
- Carbody issues
- Car weight considerations
- Better maintenance procedures
- Problem diagnosis / debugging
- Often overlooked considerations

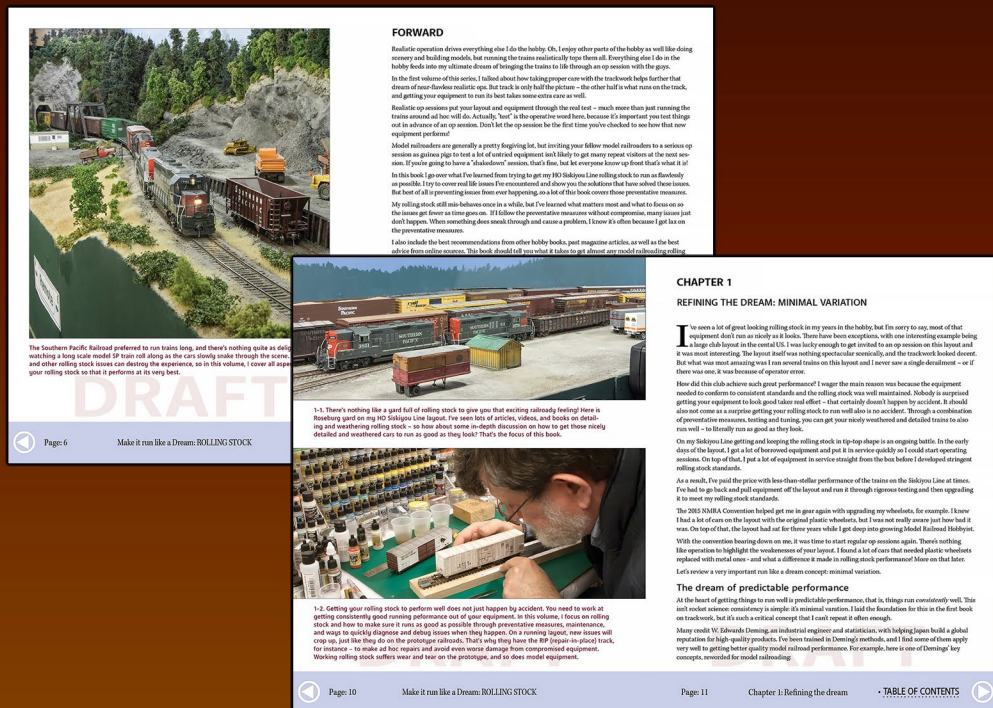



39. Dirk Reynolds built the yard tower in this shot of a hump yard at sunrise.



40. Union Pacific power pulls a freight through very arid territory. In the video, I run trains through this scene in real sunlight.



41. This is a fun mix of models to set the era of the photograph, some time around this country's bicentennial celebration in 1976.



 [Click here to rate or comment on this article](#)

42. This handsome set of Conrail units basks in the light of a partly sunny day, waiting for their next road assignments. ☑



MRH MARKETPLACE

Where the Rail Meets the Sea...



CRAFTSMAN KITS & BUILT-UPS
HO - O - N Scale



53' Passenger Steam Ferry Kit - H136W-HO

www.seaportmodelworks.com

Click here for our website:

Port Costa
R.H



2 stall R.H
in HO scale all
laser cut wood
#2097 \$170

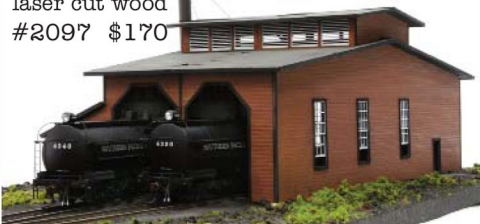

421 Hopkins Road, Dummerston, VT 05301

802-258-3869

See all of our fine products from HO to F/G scales at:

www.bantamodelworks.com

**NEW #8 HO/HON3 DUAL GAUGE
LEFT TURNOUT TEMPLATE**



Anyone can
build track with
Oak Hill.

Template Kit comes with everything
cut, filed, gaped, and formed to make
5 turnouts, plus 1 free tube of Pliobond.



See Ken Patterson's What's Neat to
see just how easy it can be!

Click to see video

www.ohrtracksupply.com

PRECISION DESIGN CO

Chains
Flat Car loads
Joint Bars
Signs & Posts

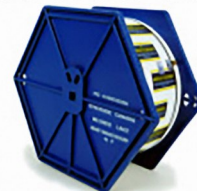

FREE SHIPPING



clever models LLC
Cardstock models & materials

Try one today!

www.clevermodels.net

MODEL RAILROAD
BenchWork

Affordable built to order Benchwork
starting at only \$20 a Sq Ft.



Yarmouth Model Works
HO scale resin kits and detail parts

U.S.A. MAILING ADDRESS
3560 Pine Grove Ave. Unit 617
Port Huron, MI 48060

TEL: 519-633-7574
pierre.oliver@start.ca

CANADIAN MAILING ADDRESS
85 Hiawatha St.
St. Thomas, ON N5P 2T5

www.yarmouthmodelworks.com

Trees

coastmans.com HO

Imagine that!
Laser Art Products

ITLA Scale Models

Olympia Tool & Die
HO Scale Laser Cut Wood Kit

CLICK HERE FOR MORE INFORMATION
www.itlascalemodels.com

LOOK
at what's new at
Black Cat this month

Click here for
our website

**CPR & CNR
Caboose Storm doors**

etched brass with plastic glass

Black Cat Publishing
(204)489-5005
ajfergus@mymts.net
blackcatdecals.com

LOGIC RAIL™ TECHNOLOGIES "Sophisticated Model Railroad Electronics"

Please visit our website and online store!

21175 Tomball Pkwy Suite 287 Houston, TX 77070 Phone: (281)251-5813 <http://www.logicrailtech.com> info@logicrailtech.com

FEATURING **America's Historic Main Street Architecture**



O-Scale model shown (HO available)

MAIN STREET HERITAGE

www.mainstreet-heritage.com

BenchWork .com



Affordable Modular (domino) Benchwork in 200+ sizes
Custom built to order benchwork also available!

PRE-SIZE MODEL SPECIALTIES

P.O. Box 6 Paonia, CO 81428 Ph. 970 527 4586 Made in The USA

Cast resin items for All Scales. Tunnel portals, bridge piers, abutments, culverts, and retaining walls. Trackside details and sage brush tree armatures.

"FREE SHIPPING see website for details"

TAM Industries
"Preserving the Romance"

The highest quality in Display Cases for sharing your excitement of Model Railroad. We manufacture Display Cases for all gauges of Model Railroad, from "G" to "N". Custom Sizes are available for some styles.



Visit us today at: www.TAM-IndustriesOnline.com

WESTERFIELD GOLDEN AGE LINE MODELS, LLC

New Kits Available:
S-40-1 Pressed Steel U/F Stock, LA&SL, OSL, UP



westerfieldmodels.com

GOODDEALSDCC
WWW.GOODDEALSDCC.COM



HOME OF THE PROGRAMMER TEST TRACK SYSTEMS

DC & DCC COMPATIBLE ALL SCALES AVAILABLE CUSTOM ORDERS DEALER INQUIRIES WELCOME

GARY COHN 106 CENTER STREET FOX RIVER GROVE, IL 60021 GARY@GOODDEALSDCC.COM

CROW RIVER PRODUCTS

"O" Scale Kit 325
The Automatic Steam Engine Stationary Power for multiple uses.
3 1/2" L, 2 1/4" W. Flywheels 1 5/8" Dia.
\$70.00 made in USA



HO & O Scale Machinery, Derricks, Engines, Hardware & Waterfront Models
Pawtucket, RI 02861 Tel 401-723-0065 www.crowriverproducts.com

?

DID YOU KNOW MRH SUBSCRIBERS GET FREE BONUSES?

CLICK TO SUBSCRIBE NOW - IT'S FREE!

HO DIESEL SUPPLY

KATO EMD SD SPECIALIST-REPAIRS-UPGRADES
New and Rebuilt Locomotives
Powered Chassis-Trucks-Motors
Bodies and Parts-Handrails-Electronics

www.hodieselsupply.com
email:kato@hodieselsupply.com

Model Railroad Control Systems

Geoff Bunza Project Boards
DCC Occupancy Detectors
CMRnet Compatible Nodes
Layout Telephone Systems [Click Here](#)
RFID Switchlist Generator
Switch Machines and Drivers

MOUNTAIN SUBDIVISION HOBBIES

www.modelrrsupply.com
FREE USA SHIPPING OVER \$29.00

NCE - SOUNDTRAXX - DIGITRAX - PECO - CIRCUITRON
DCC SPECIALTIES - INTERMOUNTAIN - CMX - ATLAS
BAR MILLS - BOWSER - KATO - MRC - TOMAR - RIX - PIKESTUFF - LOGICRAIL - CENTRAL VALLEY AND MORE!

RULERS-of-the-WORLD

Scale Rulers \$4 each
Over 200+ scales!
Metric or Imperial

www.rulers-of-the-world.com

Great Decals!™

FEC, Interstate, Virginian Railway, & L&N Titles
After Hours Graphics Line
Coupler Gages and More
In O, S, HO, and N Scales

OCEAN SPRAY BOXCARS

BY MICHAEL TYLICK, MMR

*Old-school scratchbuilding
with wood expands a Down
East narrow-gauge fleet ...*





Click here to rate or comment on this article

OTHER THAN A FEW BACHMANN GONDOLAS AND steel hoppers (see MRH for February 2016, #72) my On30 Marshfield and Old Colony Railroad had no rolling stock to fill expanded track construction.

A few boxcars would help fill out the roster, so I began consulting my computer for two-footer drawings and photos. Much to my surprise, bright red “Ocean Spray” boxcars came up on a Bing Images search. I was able learn much more with just a little digging. For those interested in a comprehensive study of these cars, I recommend the book *Bridgeton and Saco River RR/Bridgeton & Harrison RR Boxcars* by Peter S. Barney and Tim Mulina.¹

It is rather remarkable that wood boxcars built over a hundred years ago still survive. The B&SR ceased operations in 1941 and its rails were quickly torn up to supply steel for the war effort.

The cars sat landlocked until after World War II when they were sold to the Edaville Railroad in Southeastern Massachusetts. The owner, Ellis D. Atwood, purchased the equipment for use in

1. Although Peter Barney has written many other books about the Maine two-foot gauge railroads, this book is not available on Amazon. It appears to only be available from their website: quickpicbooks.homestead.com/files/2ft_bks/BSR_Boxcars.html.

A large number of sample pages are included on the website. They included enough information that it was unnecessary to purchase the book for my purposes. It was priced around \$30 with shipping. As I was planning to build the car from the few photos I had, the book was helpful to me mostly for dimensions and history. I know I should support the efforts of researchers but other than building the cars, I really was not all that interested.

his cranberry bog plantation. Since he had also purchased some passenger cars, he started offering Christmas train rides to the locals, and the railroad eventually transformed into a large tourist attraction.

The railroad had its ups and downs, and fell on hard times in the 1990s, when much of the original equipment was sold off. Atwood died in 1950. The railroad went through a succession of managers and owners until the late 1980s when his heirs, who still owned the land, took steps to evict the then-owner and operator of the railroad. Edaville has recently been extensively renovated into “ThomasLand at Edaville USA”, which shows all signs of becoming a success.

Trains still ply the original two-foot gauge rails but the B&SR equipment is back in Maine where it is owned and operated by the Maine Narrow Gauge Museum in Gray. Although the cars almost certainly carried cranberries during their time at Edaville, it appears they were not painted in the bright red scheme until the early 1950s. I do not recall seeing them in the 1980s.¹

On a real world map the southern end of the Marshfield and Old Colony² is less than 10 miles from the Edaville railroad, so it is feasible the two narrow gauge railroads could have connected.

I was unable to visit the existing cars in Maine, but by scaling the photographs and studying other sources, I believe the existing cars were either the early 26’ or 28’ versions built in the 1880s.

2. My On30 M&OC is loosely based on a long-abandoned branch of the standard gauge New Haven (Old Colony) railroad that ran from Braintree along the South Shore to rejoin the Plymouth Line at Kingston. The northern half of line now sees daily service as the Greenbush Line of the MBTA commuter railroad.

3. Although these cars are nearly identical and are built at the same time, they would count as three scratchbuilt cars for the NMRA Car Builder Achievement Award.

OCEAN SPRAY BOXCARS | 5

Since there is never enough room on a model railroad, I chose to build the shorter cars for my models.

Wood or styrene? Styrene is neater and faster, but wood is a natural material and is, after all, what the prototypes were built from. And it's fun to go back a little in time to the way freight cars were modeled in my younger days. I decided to build three cars, enough to take advantage of mass production methods to expand my roster more quickly but not so many as to make construction tedious.³

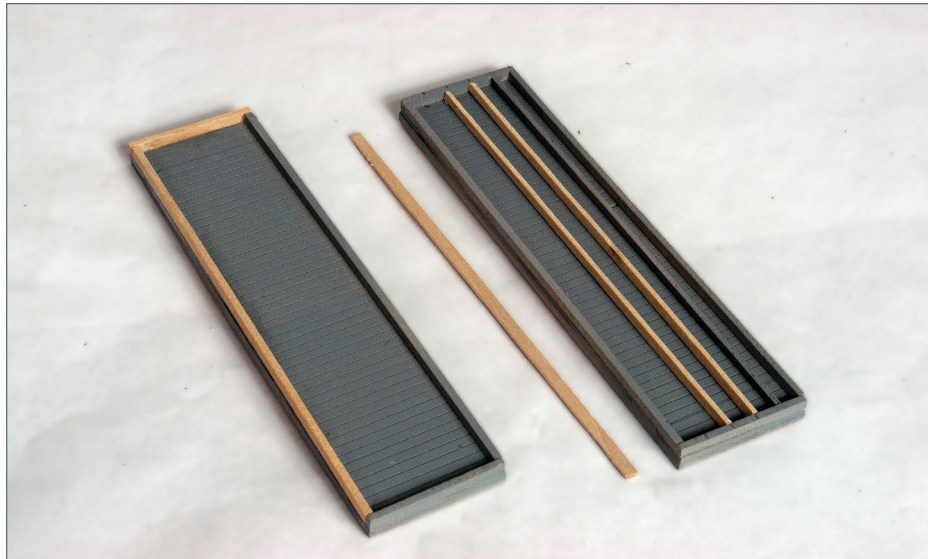

1. The floor is a 1/8" thick subfloor laminated to a scribed 1/8" x 1/16" thick visible floor. Although the underside will never be seen in everyday use, I used scribed siding in case I decided to detail the underframe at some point. To this end I also included the wood framing beams. It's really not much extra work, and doing this will garner extra points over a blank floor for a model contest or an NMRA achievement award³. It is often said by those who take the time to add unseen detail that they know it is there. I find that I quickly forget that which I can't see.

OCEAN SPRAY BOXCARS | 6

If white or yellow glue is used sparingly, it dries quickly enough that the first car is dry enough to handle by the time the third car is done. The assembly is almost as quick as if styrene were used, without the need for toxic solvent cements.

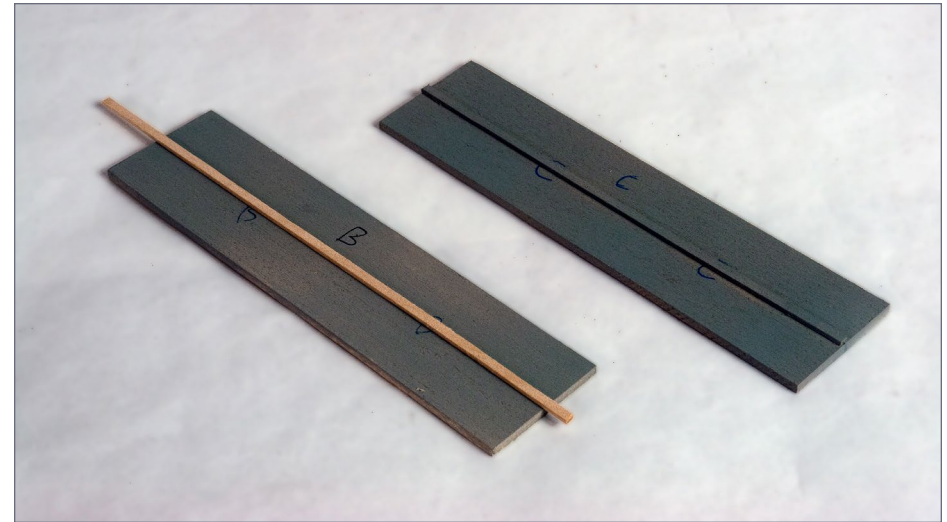

2. Milled roofing and flooring is not commercially available for two-foot gauge models so I cut my own. To insure accuracy, I cut the end and roof stock with the saw fence at the same setting. A 1/16" x 1/32" strip serves as the riser for the roof peak. All wood was cut from appropriate thickness basswood "blanks" from Midwest Models on a light duty Micro-Mark table saw. This saves multiple trips to the hobby shop or Amazon to try to find the correct size lumber. No matter what I do, I always forget something – this way I always have the correct size immediately on hand. I always cut at least fifty percent more of a size than I think I need. I rarely have much left over.

OCEAN SPRAY BOXCARS | 7

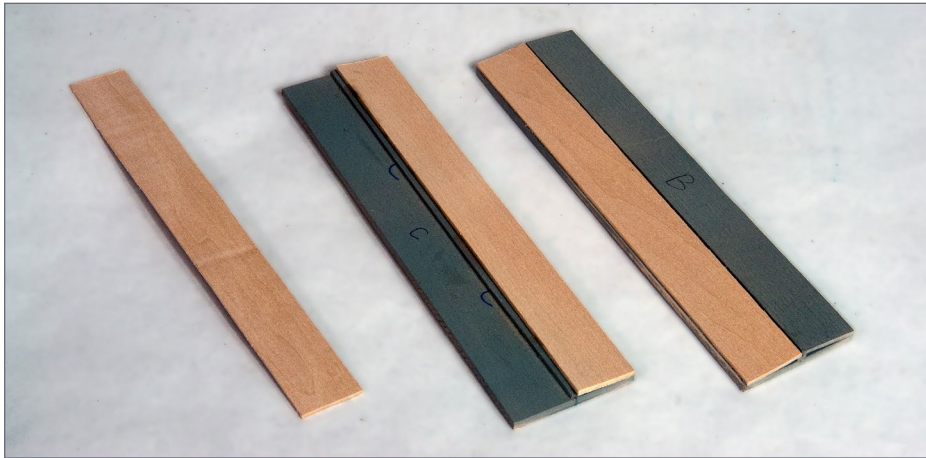

3. 1/32" wood is installed to create the peaked roof. This is a sub-roof. The sides and ends are trimmed flush with the base.

OCEAN SPRAY BOXCARS | 8

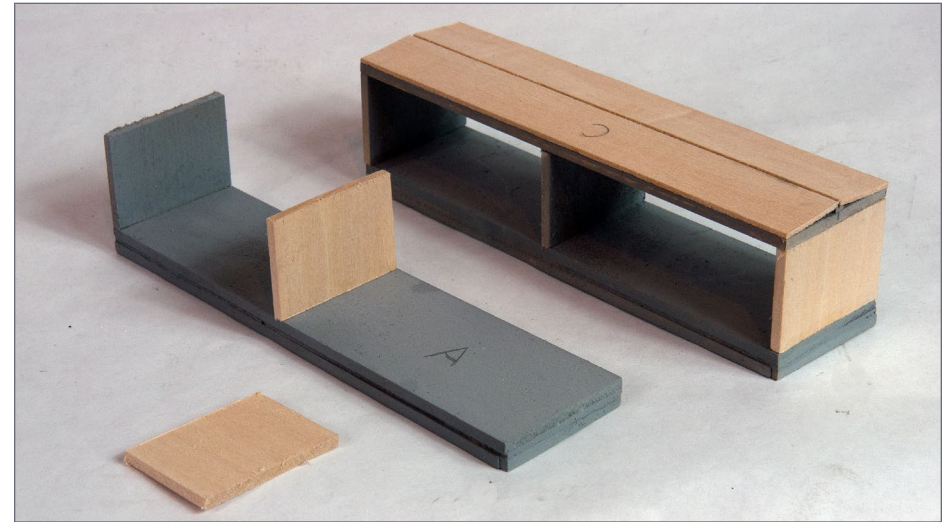

4. The end and center blocks are glued in place. Use squares to check the accuracy. Also be sure to take the depth of the floor and roof stack into account when cutting the vertical blocks to the correct length. Some pieces are primed for photographic purposes. If wood is primed on both sides, warping is essentially eliminated. Yellow carpenter's glue is usually recommended for wood assembly but this glue does not adhere well to painted surfaces. White Elmer's glue does, and is plenty strong enough for model work.

~125,000 have seen this MRH video - *have you?*

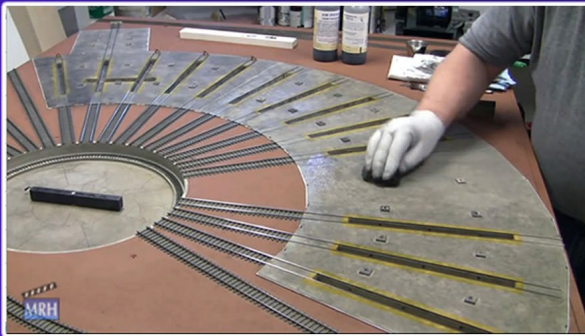

Watch the
video now



Click here to rate or
comment on this article

OCEAN SPRAY BOXCARS | 9

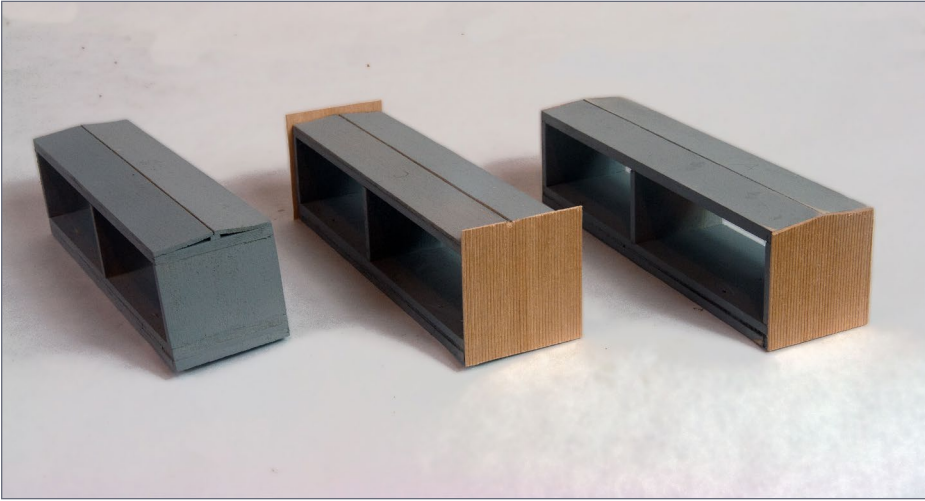

5. $3/32'' \times 1/16''$ thick scribed siding is glued to the end blocks. I find it easier to cut finished parts oversize, then trim and sand them to the correct size.

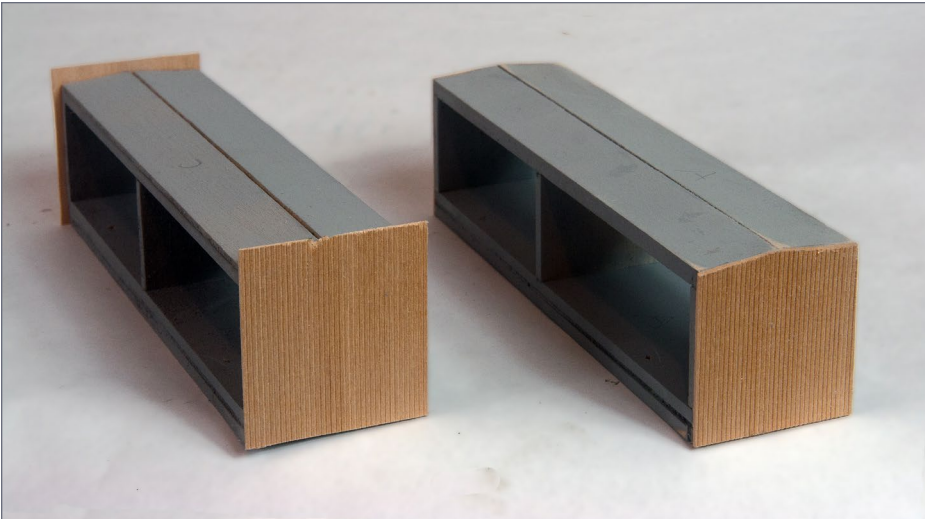

6. A closer view of the end siding. Since they will be covered by fascia boards, minor flaws are acceptable on the upper edges.

OCEAN SPRAY BOXCARS | 10

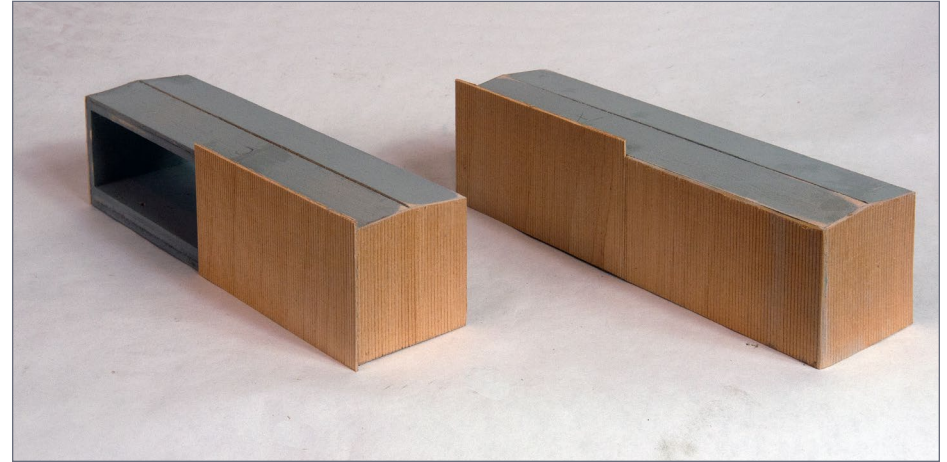

7. Siding is applied to one side of the car. The pieces are not wide enough to cover the whole side, but the joint can be placed in the center so they can be securely glued to the center block. The freight car door will also assist in hiding a joint which is rarely perfect. Note that the cars are now marked with letters. Despite my best efforts, variations inevitably creep into each car. Marking helps me make the parts to better match each car.



[Click here to rate or comment on this article](#)

OCEAN SPRAY BOXCARS | 11

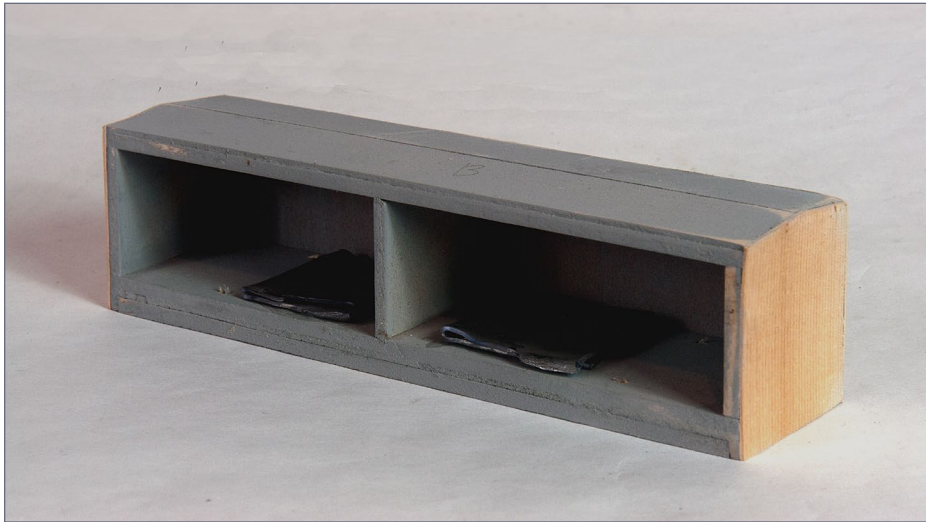

8. Wood car models are very light so they will never track well unless weight is added. Interpolating the NMRA standards between HO & O scales, I arrived at a weight of 5.3 ounces. The car and all of its hardware was placed on an old balance scale from a science kit. Lead chimney flashing (available at lumber yards) was added until the correct weight was reached. Fastening with five-minute epoxy makes sure the weights will never shift.



[Click here to rate or comment on this article](#)

OCEAN SPRAY BOXCARS | 12

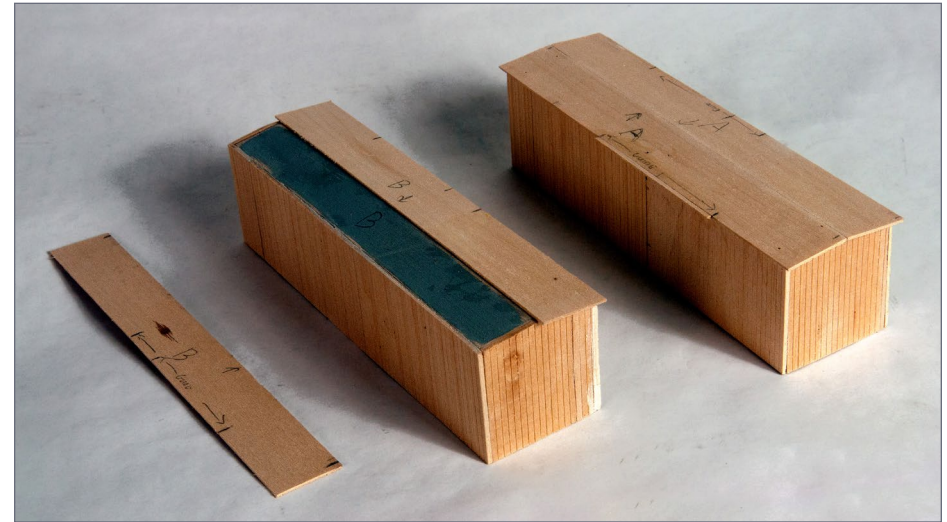

9. Now that the true thickness of the walls is established, the outer, overhanging roof is attached. Allow about 1/16" overhang since half of that will be taken up by the fascia boards. Careful observers will notice that a 1/16" x 1/32" strip has been attached to the sides to accommodate the freight door tracks.

**Did you know
there's an
MRH index
available?**

[CLICK TO FIND OUT MORE](#)

OCEAN SPRAY BOXCARS | 13

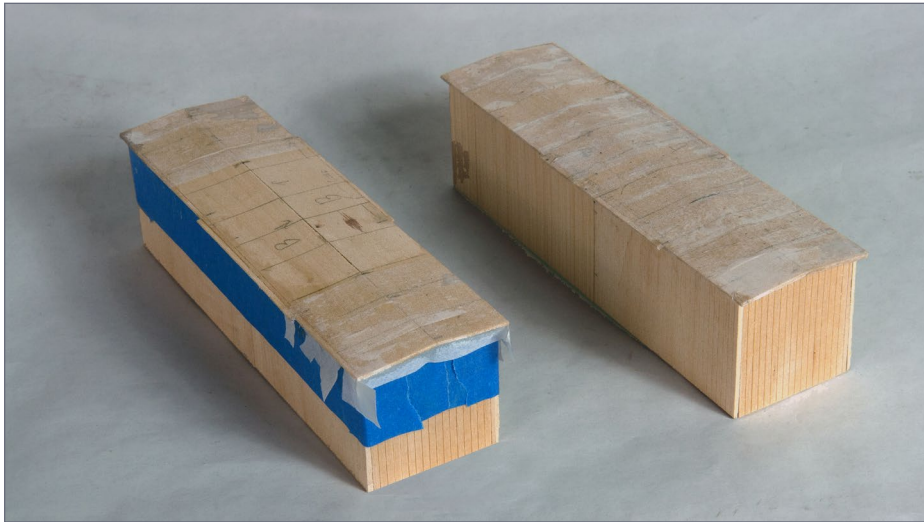

10. Many older cars had their roofs protected with canvas, and this seemed a simple way to finish mine. I used an old HO scale method of gluing tissue paper strips to the roof to simulate the canvas. It seemed easiest to cut the strips oversize, trimming them when dry. The blue tape prevents the strips from being glued to the siding. Although it did not become apparent until painting and weathering, I thought the canvas was too fine. I had tried muslin strips on a trolley car years ago, and this seemed a little coarse. I am not certain what I would use next time; perhaps copy paper.



[Click here to rate or comment on this article](#)

OCEAN SPRAY BOXCARS | 14



11. The fascia boards will fit better if they are attached after the roof and sides are joined together. Again, it is easiest to cut the pieces oversize, and cut and sand to length.

Did you see this MRH video?



**A full-sized F7
cab in the
layout room?**

Watch the video now

OCEAN SPRAY BOXCARS | 15



12. Showing where the door will go: I was not able to show all the steps in one photo, so there are three.

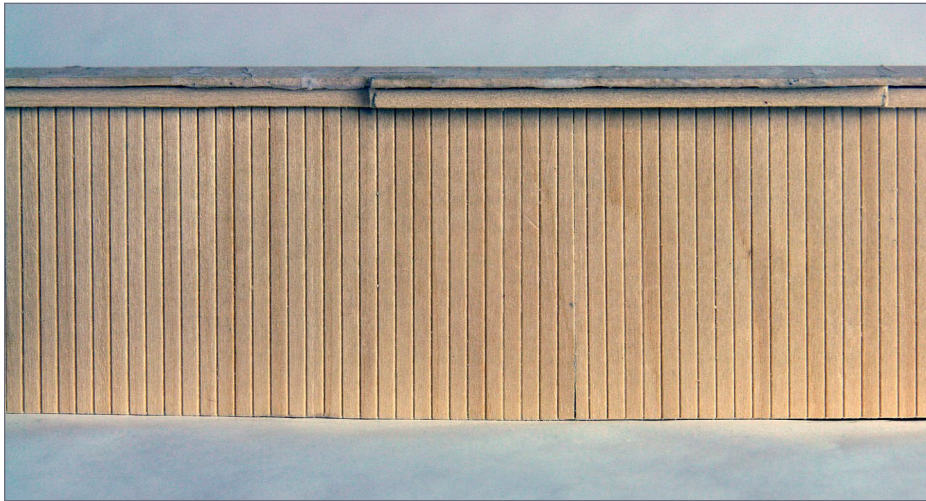

13. The door track is installed. Mine is merely a piece of 1/16" x 1/32" stripwood. A correct system of rollers, tracks, and covers will never be seen, but would gain points for a model contest.

OCEAN SPRAY BOXCARS | 16

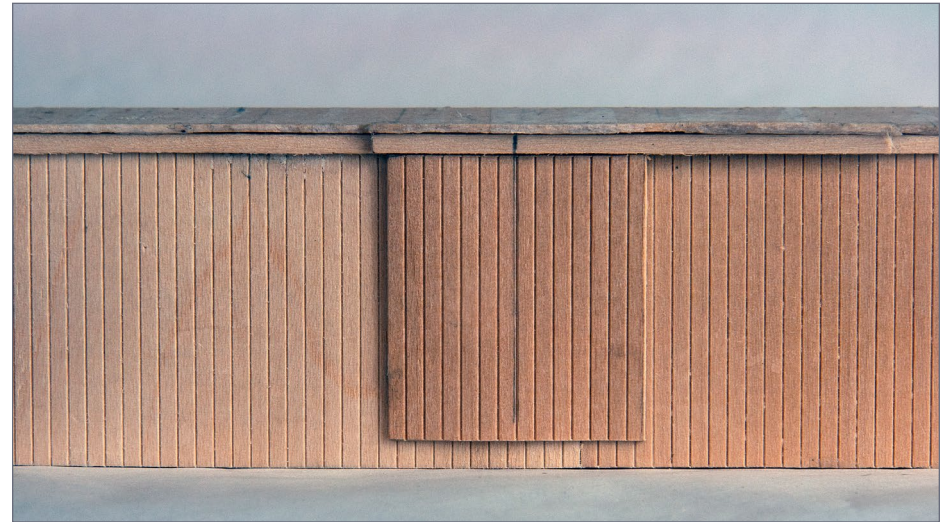

14. The door is cut from 1/32" x 3/32" scribed sheet. Center lines assist in aligning the door to the correct location on the track.



15. My next decision was whether to complete the roof or the underframe first. I picked the underframe. I think it was a good choice. I feel certain I would have damaged the fragile roof walk and brake wheels had I done the opposite.

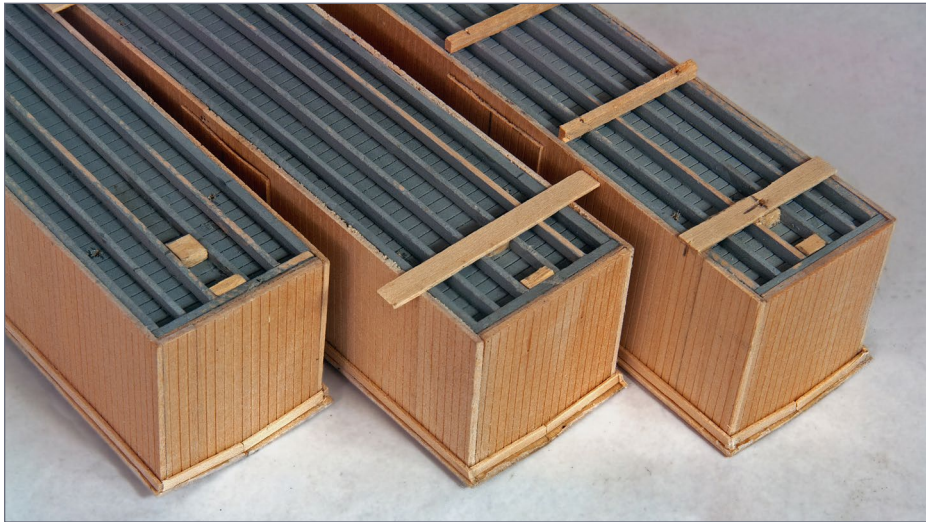

16. The prototype photos provide no information on the underside, so my plans are based on the details of a Bachmann gondola car. This is probably typical of wood car construction. A wood block was placed under the coupler pockets and the truck centers to provide material to hold the screws. A 1/32" x 1/4" bolster came next. The queen post beams are 3/32" x 1/8". It is much easier to drill locating holes before detail is added to the sides.



17. A closer view of the underframe details. A 1/8" thick block has been glued in place to bring the couplers to the correct height. Since all of my locomotives are from Bachmann I copied my truck and coupler standards from their gondola.



Click here to rate or comment on this article

Want to help keep MRH free?
Then *click on ads!*



18. Ironwork is added to the car ends. The coupler buffer pad is first, followed by corner angles and reinforcements for the truss rod ends with nut-bolt-washer castings. Styrene would be a good choice for metal components, but I find it difficult to glue styrene neatly to wood. Index cards are attached neatly and dependably with white glue. For a small area, they provide a smooth, "metallic" surface. "Rivets" are embossed from the rear with a push pin. Not contest quality work but more than adequate for layouts and even NMRA achievement awards.



19. Side and end detailing is completed with bent .019" wire and Grandt Line ladders. I simplified the process by making some simple styrene drilling and bending jigs for the wire. They lasted just long enough for the three cars. For contest models I probably would probably have carefully drilled the 32 additional holes (for each car) for the correct grab irons, but I saw the Grandt ladders in the catalog and they seemed just too good to pass up. The retaining rings for the coupler lift bars are bits of wire insulation. To attach these, I tried a new glue: Loctite Power Grab All-Purpose Interior Construction Adhesive. I think I may have found what I was looking for; a glue that has a long shelf life, that is strong and flexible, but also is neat to apply and easy to clean up. The horizontal board across the left car end was copied from a repair seen on one of the prototypes.



[Click here to rate or comment on this article](#)



20. Details around the door area included a Grandt door latch, some paper and wood bits, and a track spike for the lower retainer. Prototype photos showed ornate metal parts for these. I had considered laser cutting or 3D printing to make these. When I saw how tiny they were on the scale drawing, I decided bits of card stock were more than adequate.

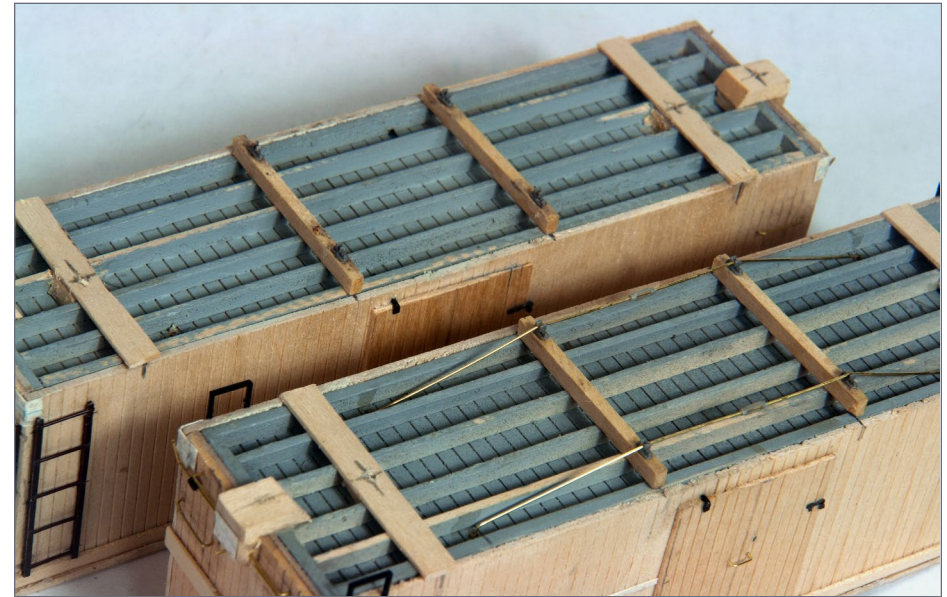

21. Queen posts, .019" wire truss rods, and turnbuckles are added. Bending the truss rods to fit was a tedious job so I was delighted the real cars only had two truss rods each. The two-foot gauge cars I modeled never did have air brakes, and I opted to eliminate the almost invisible hand brake rod and clevis mechanisms. For those who would like to include them, suitable parts are available from Grandt and San Juan Car Co. Were my cars to be used for a contest or an NMRA achievement award I probably would have gone the extra mile.



[Click here to rate or comment on this article](#)

OCEAN SPRAY BOXCARS | 23



22. In some ways, building a model railroad car is much like building a real house. The main shell goes together quickly, but the finish work seems to take forever. Sooner or later, all of the details are added, and it is time to prime the completed car.

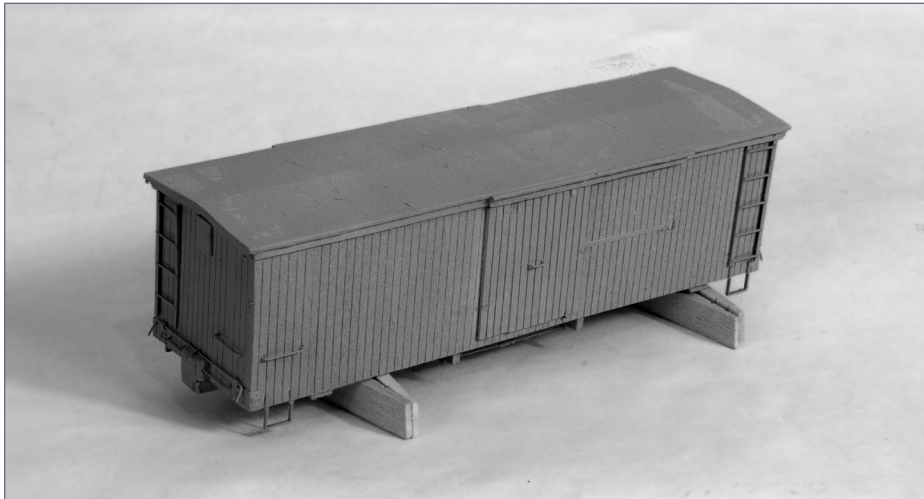

23. Spray the primer from both the bottom and the top to avoid bare spots. I was unsure how I was going to paint the roof walks, so I decided to leave them off until painting and lettering was complete.

OCEAN SPRAY BOXCARS | 24



24. The prototype underframes were painted either gray or box-car red. My photos were inconclusive so I chose the latter and used Americana Burnt Umber acrylic craft paint. After painting the underframe the trucks and couplers will be installed. I used Bachmann EZ Mate couplers in Kadee pockets to match those on my other equipment. I added an .020" styrene washer to the bolsters to bring the couplers to the correct height. The smooth styrene will also make a better bearing for the truck bolster.



[Click here to rate or comment on this article](#)

OCEAN SPRAY BOXCARS | 25

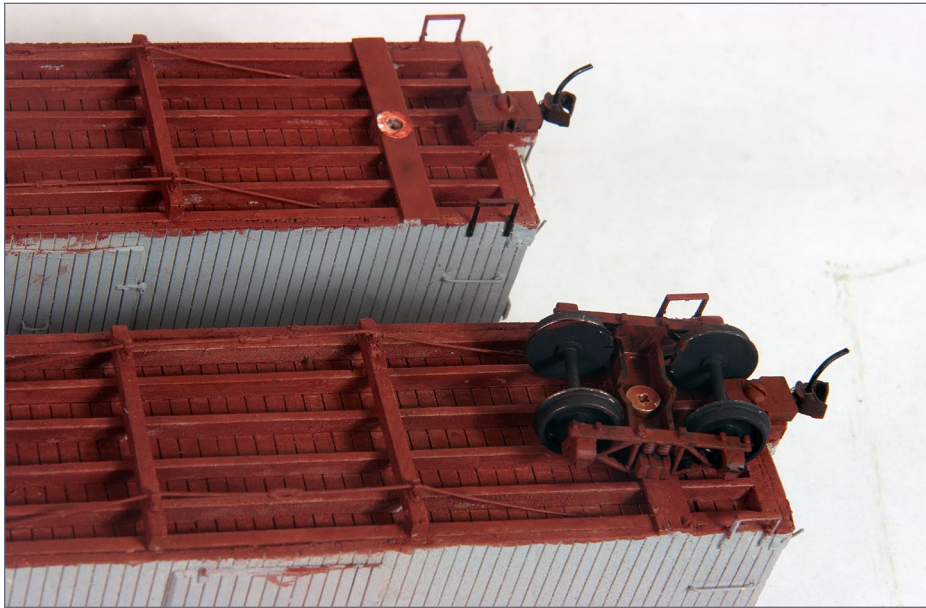

25. The underframe with a second coat of paint and the Bachmann arch bar trucks installed. Painting the wheels and trucks contributes greatly to the appearance. I painted the trucks with Burnt Sienna and the wheels with Delta Ceramcoat Charcoal.



26. Three bright red cars seemed too many, so I decided to paint one car in boxcar red. The photographs show small detail differences between the cars.

OCEAN SPRAY BOXCARS | 26



27. The Cranberry Car sides are painted with Color Traditions Cherry. This paint can be difficult to find but Americana Santa Red is a close match. The gray roofs give the cars a snappy appearance. They looked freshly painted but the color could have carried over from the original B&SR paint. I used Apple Barrel Quaker Grey.



28. The two painted cars are ready for lettering.



29. The M&OC lettering was printed on an Alps printer by a friend, and the logo was printed as part of a custom sheet from Highball Graphics (highballgraphics.com). I had drawn the artwork for the Cranberry Cars so it was a relatively simple matter to adapt the Edaville logo to the M&OC – a fitting logo for a Massachusetts narrow gauge line. There was no dimensional data on the prototype cars, so I was spared that task on the models. I think the cars look much neater without all that cluttered lettering.



30. The painted and lettered cranberry car.

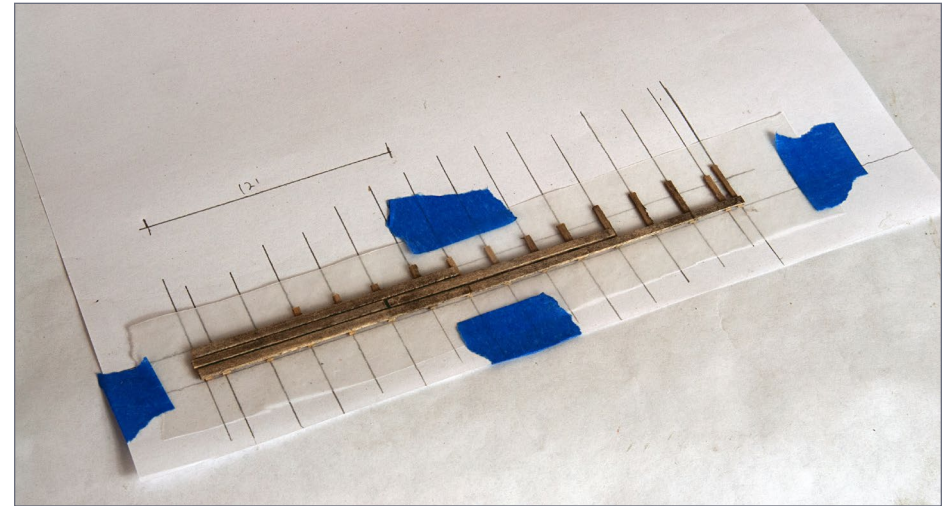

31. The cars still needed roof walks. I am glad I left them for the end. Uncertain on how to proceed, I tried a new method for building them. Using white glue, I lightly fastened the 1/16" x 1/32" supports to a wax paper pinned over my drawing. The 1/8" x 1/32" roof walk strips were glued over this. When dry, everything was trimmed and sanded to the correct length. Since this is O scale, I made sure none of the roof walk planks were more than ten scale feet long- a small detail that is easily included.

 [Click here to rate or comment on this article](#)

OCEAN SPRAY BOXCARS | 29

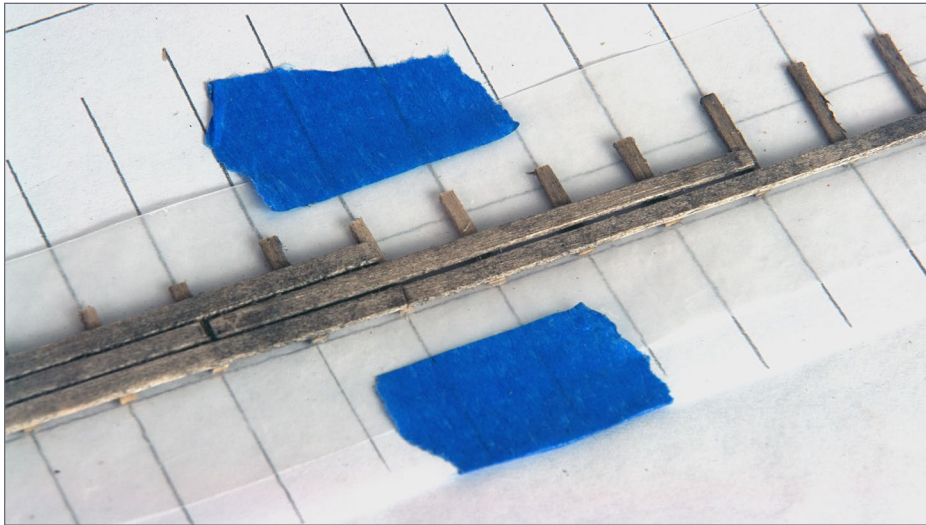

32. A closer view of the roof walk construction. Since I was unsure if the roof walks were to be left unpainted, the wood was pre-stained with an alcohol/India Ink wash.

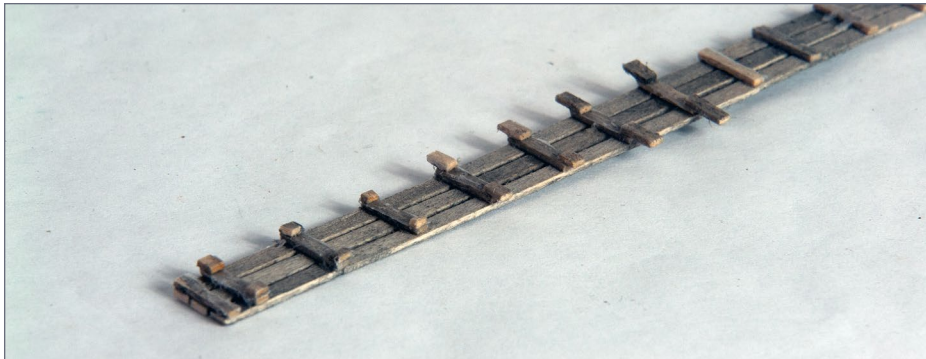

33. I could not think of a good way to cut the roof peak angle into the supports, so I built them from 1/32" thick wood, about half the thickness of the support. I built up the ends of the supports with 1/32" scrap in order to create a space for the roof peak. This is not completely accurate and might cost me points in a contest, but construction was simplified considerably. No one will ever be the wiser.

OCEAN SPRAY BOXCARS | 30



34. I had determined that the boxcar red car would have a matching roof, so I painted one of the roofs that color and tested it on the cranberry cars. Boxcar red may have been accurate. I had no way of checking but it reminded me of the old plastic boxcar kits that always had a black roof walk, no matter what the car color. The unpainted walk just looked wrong against the neat gray roof.



35. The gray roof walk seemed to look the best. Before the bright red cranberry scheme was applied at Edaville, the cars were painted either light gray or boxcar red.

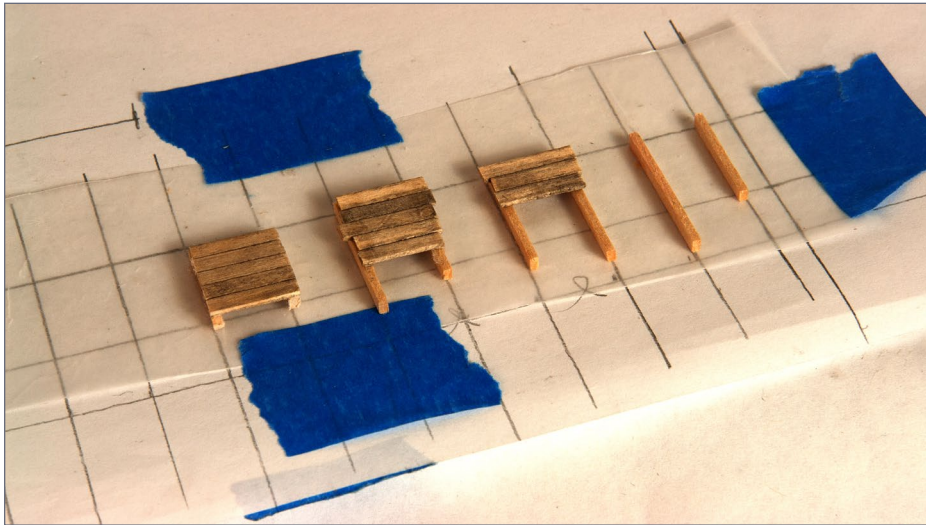

36. The roof end platforms were built the same way as the roof walk.



37. Showing the end platforms in place. Unlike those on most boxcars, the platforms were level and did not slope with the roof.

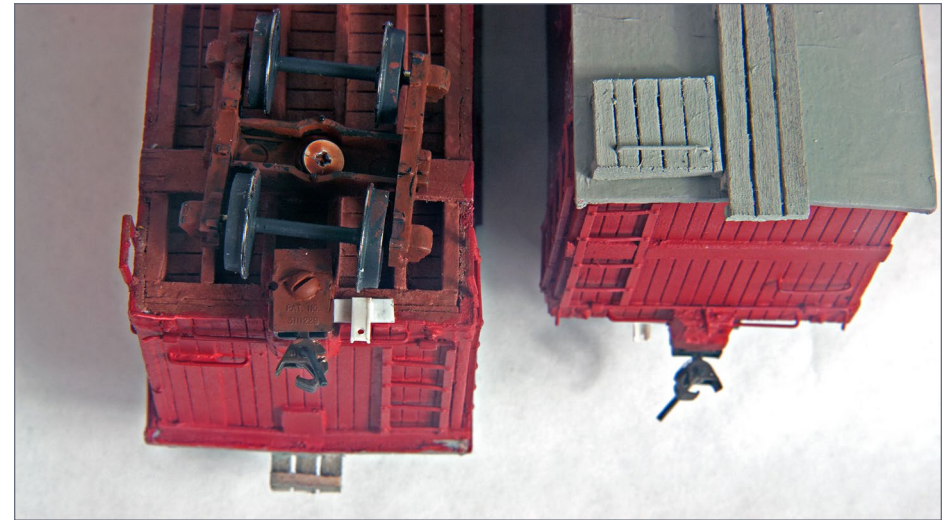

38. A short length of .100" channel has been drilled and glued to the .020" x .125" floor mount.



39. The upper brake shaft retainer is also cut from .020" styrene. Too small to really worry about the detail cast into the prototype.



40. (Above) Cutting and bending the roof walk end brackets from metal strips is frustrating at best, but cutting pre-painted strips from an index card is simple. They are scored and bent to fit. Rather than try to plan the exact angle, it is simpler to glue them to the roof walk end first and then bend them to reach the end of the car.

41. (Left) The completed brake staff and wheel.



42. A complete and freshly painted cranberry car.



43. The completed and freshly painted M&OC car. At right is a size comparison between narrow and standard gauge cars. Both are O scale.





44. New cranberry car on my M&OC layout.



46. To try something different, I weathered the cars with Pan Pastels applied with makeup brushes. As advertised, weathering with this technique proved to be very quick and easy.



45. New M&OC car.



47. I wanted the two cranberry cars to look different, so I used different colors and brushes on each, and I did them on different days.



48. The other finished cranberry car.



49. M&OC Shay 315 pushes a cut of cranberry cars across the North River causeway into Scituate, MA.

Please tell your buddies about MRH!

WE RELY ON WORD-OF-MOUTH TO GROW AND A BIGGER CIRCULATION MEANS MRH IS MORE LIKELY TO STICK AROUND FOR A LONG TIME TO COME!



[Click here to rate or comment on this article](#)



50. Steaming by the South Shore Coal Company trestle in Marshfield Hills.



[Click here to rate or comment on this article](#)



51. At the Parker and Tremont loading dock, kitbashed from a Bar Mills kit.

TrainMasters TV is part of the MRH product family.

TMTV members not only get great network TV level videos, they help pay for MRH and keep it free ...

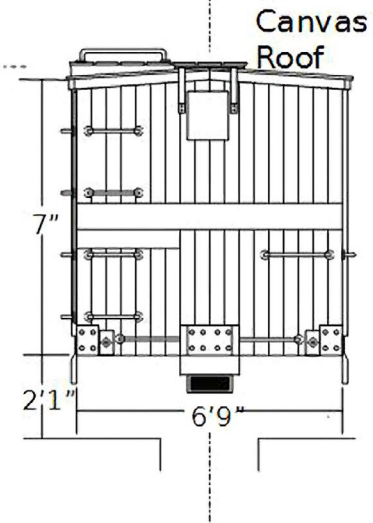
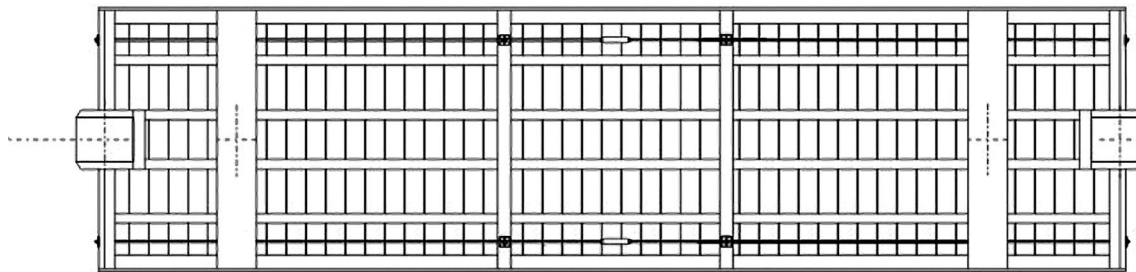
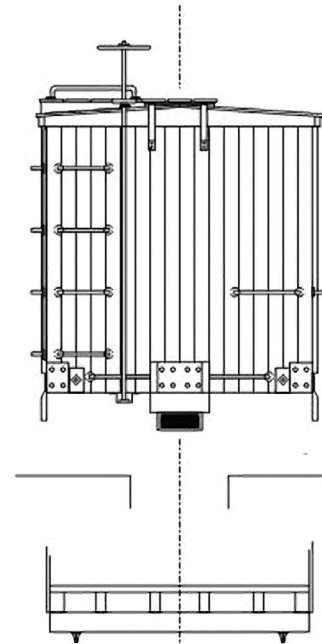
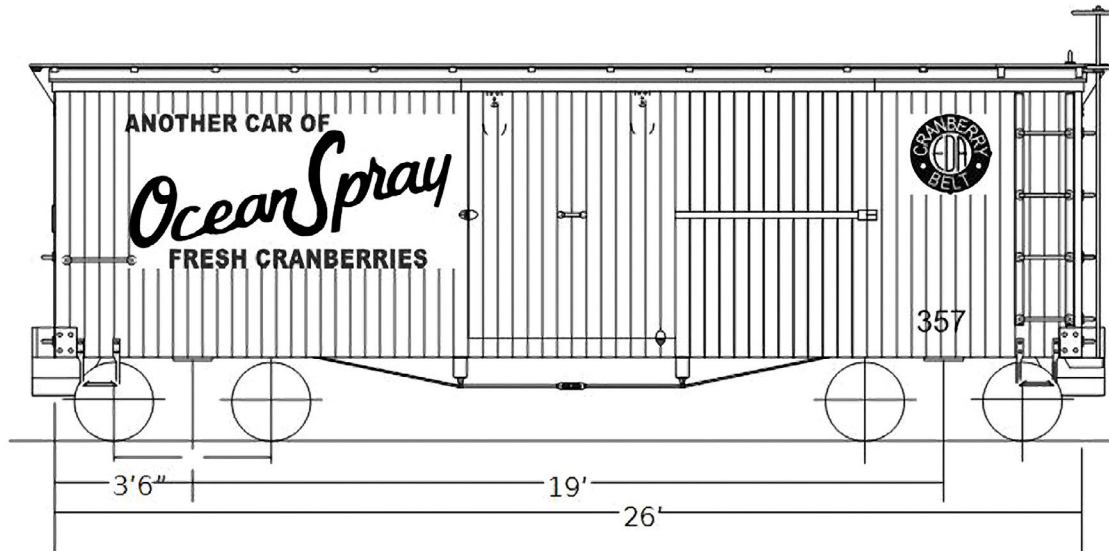

On30 Edaville Boxcar

Michael Tylick



8/15

52. Plans for this car.

OCEAN SPRAY CAR NOTES

“The boxcar is an old B&SR car.

“If I recall correctly, a couple of boxcars were lettered for Ocean Spray products when they were at Edaville. MNG (the Maine Narrow Gauge Museum) repaired or repainted one of them in a nod to the cars’ time at Edaville. Ocean Spray is a good-sized company that produces (among other things) cranberry products. Since Edaville had the largest cranberry bogs, much of their berry harvest went to Ocean Spray.

“As you probably know, Mr. Atwood originally built the railroad to serve his bogs and screen house. It was natural to acknowledge the company that was a major customer. Did the box car ever carry cranberries? Yes, it would have – back in the early years at Edaville. Was the car lettered for Ocean Spray at the time? Probably not, as I don’t think the car lettering was done until later.

“That’s the story in a nutshell.”

– Stewart “Start” Rhine

Wiscasset, Waterville, & Farmington Railway Museum yardmaster

Construction notes

Building wood cars is a dying art, but fun. Many variations on these cars were built over 30 years . Twenty-eight were made, in batches of five or less. The later ones are longer and some have four truss rods.

I primed all of the inner body. Usually I would not except for photos – I never have problems with cars when done but since some parts are primed I am afraid of warping.

Of the wood commercially available, 1/32” scribed siding looks closer to the photos than 1/16” and looks better. It’s much easier to trim and sand nicely. It represents about 2.5” siding; maybe a little small but it looks OK. 1/16” siding just looked too big. For wide boards I changed to 3/32” x 1/16” siding. Four-inch boards look much better, and it’s worth changing. I was visually confused by the size of the O model, which is close to an HO car. Now thicker wood looks better on ends.

Priming was handy to help show the basic construction, but now I worry too many coats will obliterate the detail, so I will give the models one light coat when they are completed.

Real cars had 4 or 5 rung ladders, more on later cars than mine, but I was lazy so I used Grandt reefer ladders with five rungs and saved drilling 96 holes for grabs. Ship model deck trick: wet holes to shrink them shut and become invisible.

– Michael Tylick



53. Photo of an actual Ocean Spray prototype car.

OCEAN SPRAY CAR NOTES CONTINUED...

COMMERCIAL PARTS O SCALE

- Brake Wheel- Grandt #88- C&S spoked
- Couplers- Bachmann #78025- EZ Mate Mark 2
- Door Latch- Grandt #5
- Ladders- Grandt #68- reefer
- NBW castings- Grandt #23- 1 1/2"
- Queenposts- Tichy #2016- 3"
- Stirrups- Tichy #2007
- Trucks- Bachmann- #29901- On30 archbar
- Turnbuckles- Grandt #54- D&RGW



Click here to rate or comment on this article

MICHAEL TYLICK

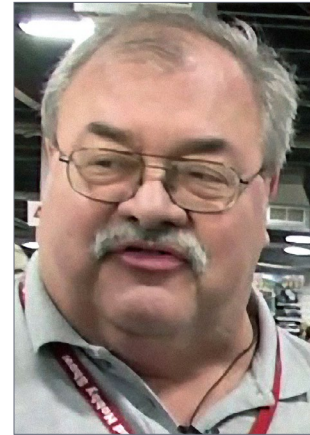

Michael Tylick has built a number of smaller layouts of various types and scales over the years. Mike has been a long time contributor to Model Railroader, Railroad Model Craftsman, the National Model Railroad Association Bulletin, and other hobby publications. He has also delivered numerous clinics and presentations on various railroad and historical subjects.

He now works as a custom builder of railroad structures and rolling stock, and has recently formed RailDesign Services for design and graphic aspects of model railroading.

Mike is a Master Model Railroader (MMR).



Click here to rate or comment on this article

WHAT'S NEW on TMTV!

Non-members: Watch episodes for \$1.49 ea, become a member for unlimited access



THE BACKSHOP CLINIC



DCC DECODED

Loksound "Full Throttle" steam



TOMA

Start Small. **THINK BIG.**

TOMA project layout: Benchwork



Crew Call

NEW Ops Series: Crew Call



Weathering / detailing rolling stock



TRAINMASTERS.TV



YES, IT'S A MODEL

compiled by
DON HANLEY



[Click here to rate or comment on this article](#)



1. Genesee and Wyoming MP15DC #45 spots loaded boxcars at doors 1 and 2 at this very busy vegetarian pet food manufacturer. Loco #45 is on hire while one of VIP Pet Foods' own Alco S2s out of action with turbo problems. Ray O'Neill took the photo on his switching layout "End of the spur."

[▶ MRH'S MONTHLY PHOTO ALBUM](#)

YES, IT'S A MODEL | 2



2. It is a hot summer August day and Railbox 38613 has just been spotted at the dock to receive a partial load of dry goods. The crew of Great Northern SW2 #159 cannot wait to get back to the yard to call it a day! One of the crew said something about ice cream ... The model is an Athearn unit that Jeff Whitney weathered to follow the prototype using acrylic and oil paints for the fade and abuse. Jeff employed pastel chalks to add the grime and grunge. He added Plano cut levers, Hi-Tech rubber air lines, and .088" ExactRail wheelsets and trucks, along with Sergent scale couplers to round out the details. Jeff credits his methods to The Weathering Shop / Rust Bucket forum. Jeff photographed the model outside on a diorama.



[Click here to rate or comment on this article](#)



BEST. BUS. EVERRRRRRR.

ORDER DEADLINE MAY 8TH
CLICK HERE.





3. Seaboard Central SD40-2s pull a cut of cars from the east end of South Yard in Griffin, GA while empty gondolas are spotted at Blaze Recycling and Metals for loading. Tim Garland lettered the engines for Seaboard Central and equipped them with LokSound decoders. Tim weathered these Kato locos from prototype photos of former BNSF units. The Seaboard Central is a Class II Regional railroad that runs between Birmingham, AL and Savannah, GA over former Seaboard Coast Line and Central of Georgia tracks. Tim's model railroad is set in the spring of 2015 and he focuses on modeling the area around Griffin, GA.

YES, IT'S A MODEL | 5

GET PAID FOR YOUR PHOTO

We pay \$40 per photo we publish. If you'd like to get your modeling in our photo feature, just start posting your photos on the MRH website, especially in the Weekly Photo Fun thread created each week.

See mrhmag.com/help for more on how to post an image. You need to be an MRH subscriber to post photos to our website, and becoming a subscriber is free, [just fill out this form here](#).



Click here to rate or comment on this article

ADVERTISEMENT

WEATHER

Like a pro. (No airbrush required!)

Click me to
LEARN MORE ...

“Simple, effective, and a lot quicker than an airbrush ...” - *Koos F.*

DVD or Digital download - From the MRH Store:
store.mrhmag.com

MRHMAG.COM



SUBSCRIBE
(free)

ADVERTISEMENT

CORNERSTONE

YOUR SOURCE FOR MODERN INDUSTRIAL PARK KITS & ACCESSORIES

HO SCALE

PRODUCT ARRIVING NOW THROUGH JUNE 2017 – ORDER NOW



Track & Rail Scale

Inspired by concrete “tip-up” warehouses, light and heavy manufacturing plants and more seen all across North America, this new series of models makes it easy to add trackside industries and support facilities to any HO layout from the 1980s to the present!



MODERN COLD STORAGE WAREHOUSE



MODERN CONCRETE WAREHOUSE

CLICK TO LEARN ABOUT THE ENTIRE MODERN INDUSTRIAL PARK SERIES!

WALTHERS

Support your local hobby shop • visit walthers.com • call 1-800-4-TRAINS

Delivery date/s and prices shown were accurate at press time; for updates visit walthers.com.
Preproduction models shown assembled and painted, some details and colors may vary. ©2017 Wm. K. Walther, Inc.

• INDEX

• TABLE OF CONTENTS



[Click here to rate or comment on this article](#)



INSTALLING TRI-COLOR LEDS INTO DWARF SIGNALS

BY JASON MILLER

1. Here is an example of what my finished dwarf signals look like.

Getting a true tri-color aspect for your signals ...

FROM THE BEGINNING OF MY LAYOUT (JL&T RAILROAD), I have always wanted to incorporate a full functioning signal system.

The more I researched, the more I discovered how much was involved. Replicating a prototypical system requires some real investment of time and money.

One issue I discovered early on was trying to replicate the color of the Conrail 1988 Signal Aspects tri-color searchlight signals. I needed an LED that could produce all three aspect colors (green, yellow, and red) for these searchlights.

This can be achieved by using bi-colored LEDs that produced both red & green, and by driving the two together can produce a yellowish color aspect. The final color when using this method for obtaining a yellow, however, can be hit and miss and is a topic of much debate among modelers who have installed signal systems.

Considering the ability of bi-colored LEDs to produce a true yellow, and for that matter greens and reds too, I started researching true tri-colored LEDs. There are several on the market – and in particular one brand has very prototypical aspect colors incorporated into a single 1/8” (3mm) LED. In fact they were deliberately designed and manufactured to have prototypical railroad aspect colors.

While researching the different kind of LEDs, I asked several of my fellow modelers if they had heard of a tri-colored LED. We got onto the topic of how a true tri-color LED might help those with color blindness. This got me thinking because I am actually red/green deficient myself.

Color-blindness (or more correctly, “color deficiency,” since actual full color blindness is very rare) can often be seen when an operator continually runs red aspects, sits at a green for too long, or doesn’t slow down when passing a yellow. Sometimes they may actually tell you they struggle figuring out the signal aspect color.

What I like about the LEDs I have chosen is they have enough shade and color variation between the three aspect colors to minimize the issues for people with color deficiencies.

INSTALLING TRI-COLORED LEDs | 3

In this article I will be installing one brand of Surface Mounted LED/diode: the RR-CirKits Tri-Colored PCB LED. This three-in-one LED features all three-aspect colors matched to actual prototypical aspect colors. I am using these on all of my searchlight dwarf and mast signals. ✓

YOU WILL NEED

Materials:

- Tri-Colored LEDs
- RR-CirKits – SS-RGY-18 LED (rr-cirkits.com/Notebook/Searchlight-led.html)

TOMAR Signals:

- H875(bl) – Single Head – Searchlight Dwarf Signal
- H876(bl) – Double Head – Searchlight Dwarf Signal

Wire:

- ESU LokSound Decoder Wire – Hi Flex Stranded, 36AWG (0.5mm) (green, yellow, red & black)

Clear Lenses:

- Bivar – LED Light Pipe PLP2-125 (1/8"-3mm)

Other Materials:

- Liquid Electrical Tape (black).
- PollyScale Grimy Black acrylic paint
- CA glue
- CA instant set

INSTALLING TRI-COLORED LEDs | 4

Tools & Equipment Required:

- Pencil soldering iron
- Solder, flux
- Small 1 – 3mm round file
- Small triangular file
- Sprue cutters
- Tweezers
- Small pair of pointy nose pliers
- X-Acto knife
- Soldering aid for holding wire and LED
- Small paintbrush
- Small (1/8"- 3mm diameter) piece of plastic sprue



2. Tools and equipment I used on this project.

STEP 1: REMOVING THE T1 LEDs

The TOMAR single and double head dwarfs have small 1/8" (3mm) T-1 Bi colored LEDs installed from the factory. These need to be removed from the brass housing. The LED is secured in the housing by "liquid electrical tape" (LET).

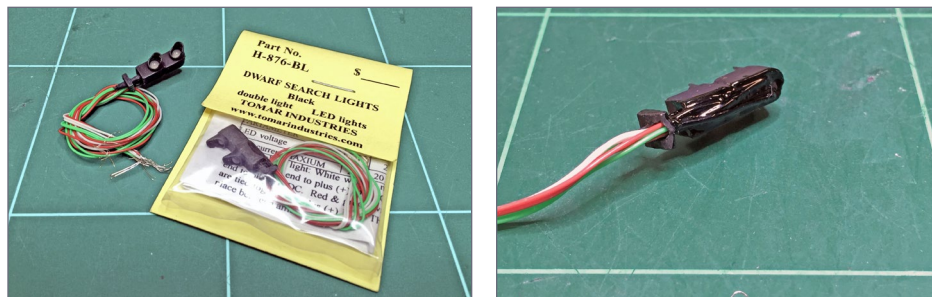

3. TOMAR H-876-BL in packaging and back, showing the liquid electrical tape (LET).

To remove the LED firstly cut along the outside edge of the liquid electrical tape, running the knife blade around the outside edge.

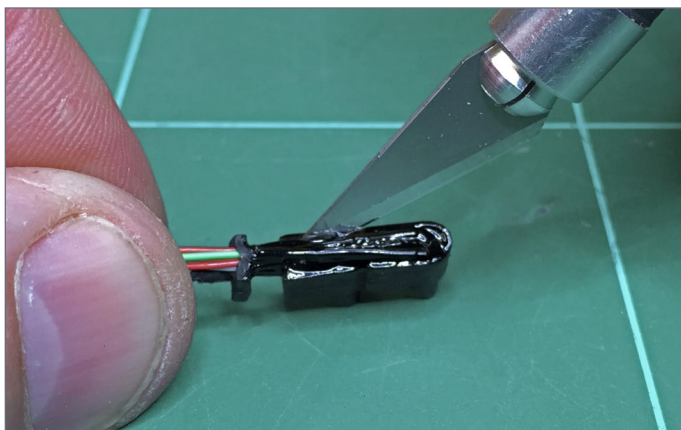

4. X-Acto Knife cutting the LET.

Using a pair of tweezers, carefully remove the LET and gently pull the wires of the existing bi-colored LED through from the base end. If you wish to not damage the original LED, do not try to pull the LED all the way out of the housing using the wires attached, they are very fragile and will break.

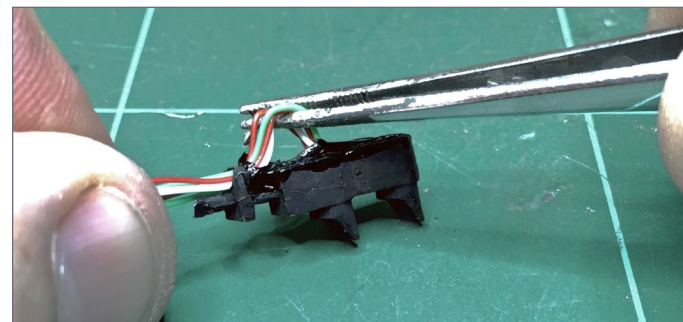

5. Removing the wires with tweezers.

To remove the existing T1 LEDs, place a piece of plastic sprue (1/8" – 3mm in diameter) into the front of the aspect opening and give a gentle push to shove the LED towards the back of the housing. This will pop the LED out with any remaining LET and keep the wire attached to the LED.

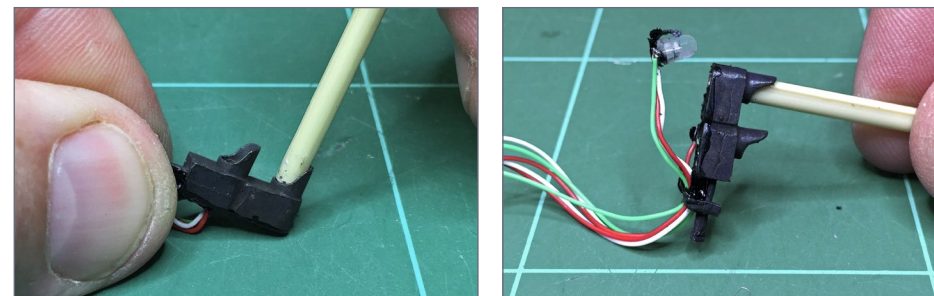

6. Using a sprue to push out one of the LEDs.

STEP 2: PREPARING THE BRASS HOUSING

To ensure an RR-CirKits LED fits in the opening, I test fitted a prepared LED with wires into the aspect opening. If needed, I used a small round file to remove any brass casting or remaining LET from within the housing.

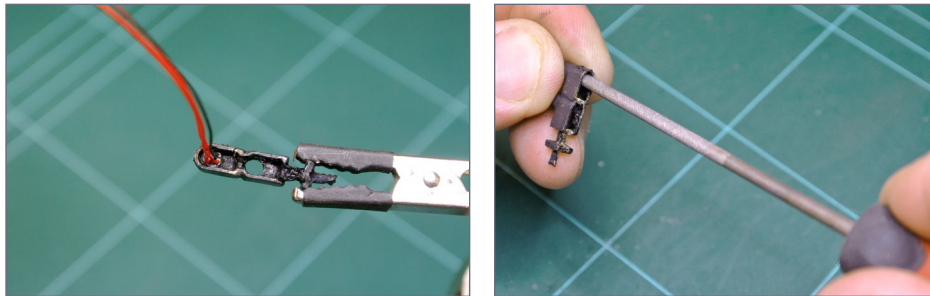

7. Test fitting an LED into the casting opening and cleaning out the opening with a round file.

At this stage I also check the small hole in the base of the casting that holds the wire in place. I make sure the hole provided is big enough to hold all eight (8) wires for the double head dwarf.

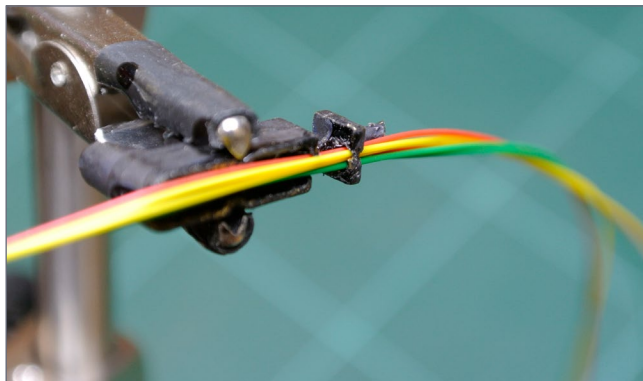

8. Test fitting all eight wires through the housing base hole.

In the bottom aspect of the housing is a small notch for the wires to sit in. When changing to the tri-colored LEDs in a double head dwarf, the notch needs to be deepened to allow for the eight (8) wires required for both LEDs. The single head dwarf notch is sufficient for four (4) wires.

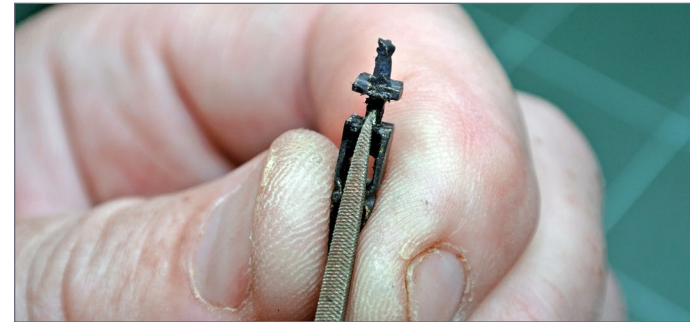

9. Deepening the notch being with triangle file.

Finally, prepare the inside of the brass casting housing by ensuring there is no brass showing on the inside. This will help avoid shorting between the wires/solder and the brass housing. If brass is showing inside the housing, re-paint it with “Grimy Black” acrylic paint until the inside of the housing is completely covered with paint.

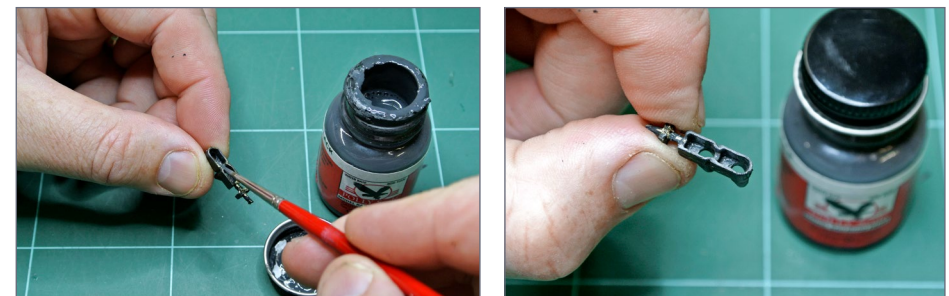

10. Painting the inside of the casting with a brush.

STEP 3: WIRING THE TRI-COLORED LED

The RR-CirKits tri-colored LED is a small diode on a 1/8" – 3mm round PCB. The batch I have are unwired and come pre-routed to the finished 1/8" – 3mm size.

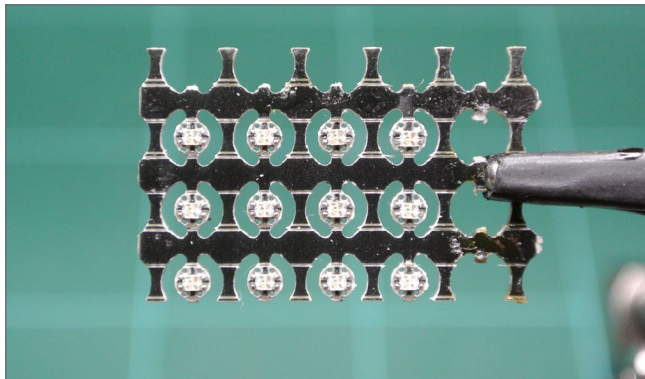

11. RR-CirKits LEDs as they come on a PCB.

First, I cut the hi-flex decoder wire to length. I'm using 24' (600mm) for the length, as it allows for both the layout bench-work thickness and enough play. I can secure the wire to the signal cable connectors without being cramped up to the underside of the layout when connecting the wires.

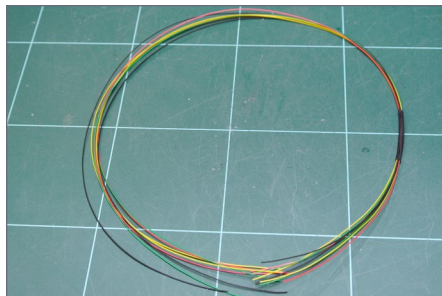

12. Hi-flex decoder wire in different colors and cut to length.

I then strip off 3/16" (5mm) of the plastic sheath on both ends, and tin the wire. The wire, even when tinned, will still fit in the holes on the LED PCB.

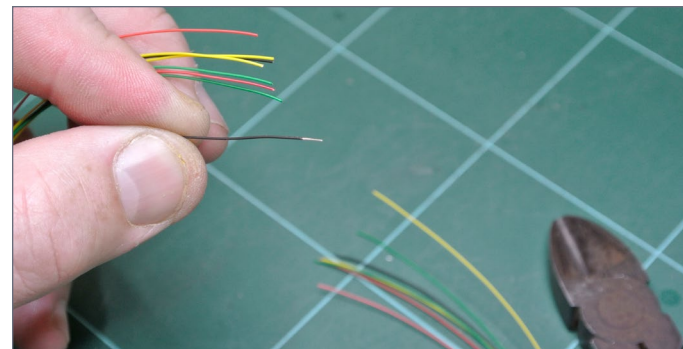

13. Wire with sheath removed and tinned.

Starting from the common anode (marked on the PCB with a square pad) solder the wires into each aspect pad. When looking at the diode the common is on the upper right, and working clockwise the red, green and yellow. As I solder each wire I check each one to ensure that the wire has been correctly soldered to the PCB pad.

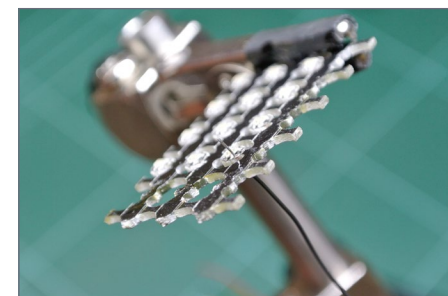
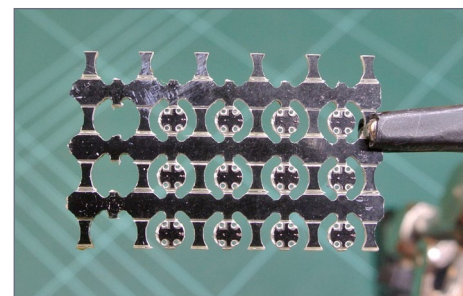

14. LED PCB and pads with wire through a pad hole.

STEP 3: WIRING THE TRI-COLORED LED *CONTINUED...*

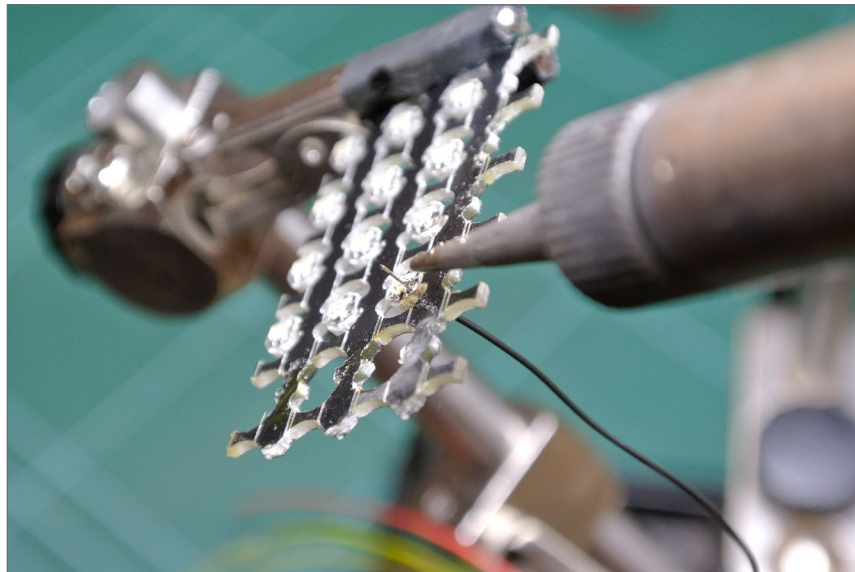

15. Soldering wire to PCB pad.

Once the wiring is completed, I tested all of the three aspect colors using a 12V power supply through a 4.3K-ohm resistor to ensure they are all operational.

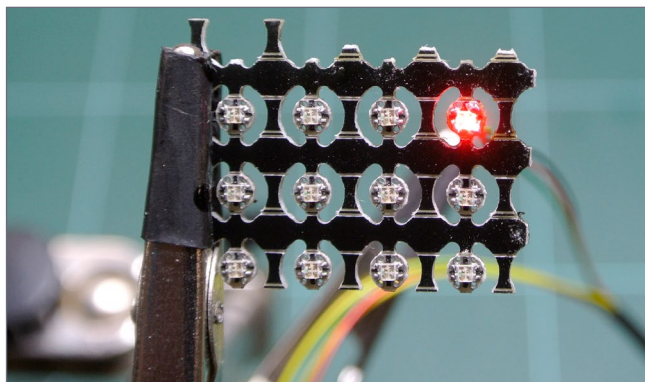

16. Testing the LED color while it's still part of the PCB array.

STEP 4: INSTALLING THE CLEAR LENSES

When the LEDs are installed in the aspect opening of the housing, the bare diode can easily be seen when looking at the signal. As a simple solution to hide the diode and spread the light evenly from the opening, I installed a small light tube.



17. Close up of Bivar light pipes.

I managed to find a 1/8"-3mm clear domed light pipe from Bivar Industries. The light pipe fits perfectly into the aspect opening of the signal housing. The only thing needed is to shorten the light pipe.

First, I shortened the light pipe length by approximately 1/8" (3mm), so that the pipe fits flush with the inside of the housing.

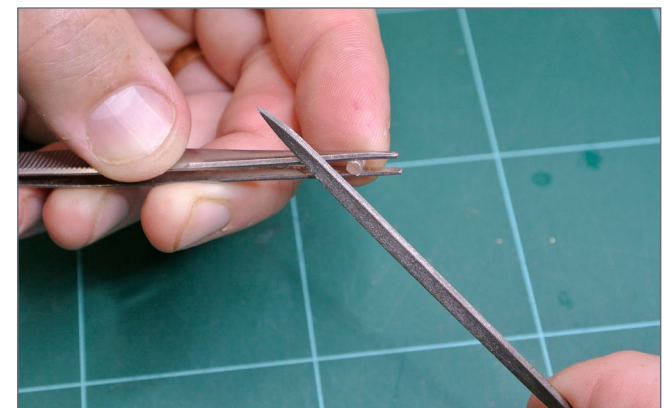

18. Shortening a light pipe.

STEP 4: INSTALLING THE CLEAR LENSES *CONTINUED...*

To install the light pipe, I placed the pipe into the opening and used a short piece of plastic sprue to push the light pipe into place. The opening diameter of the aspect housing is snug enough that the light pipe will hold in place just with friction. If it is loose, a small amount of CA around the edge will hold it



19. Light pipe being pushed into the housing opening.



20. Light pipe in place from reverse side.



21. Finished light pipes from the front.



[Click here to rate or comment on this article](#)

STEP 5: INSTALLING THE LED

To install the LED into the signal, I positioned the LED into the back of the housing with the common wire (black) to the upper right side of the housing when looking at the back. I choose to do this so that all of the dwarf signals are common in appearance when the aspects are lit.

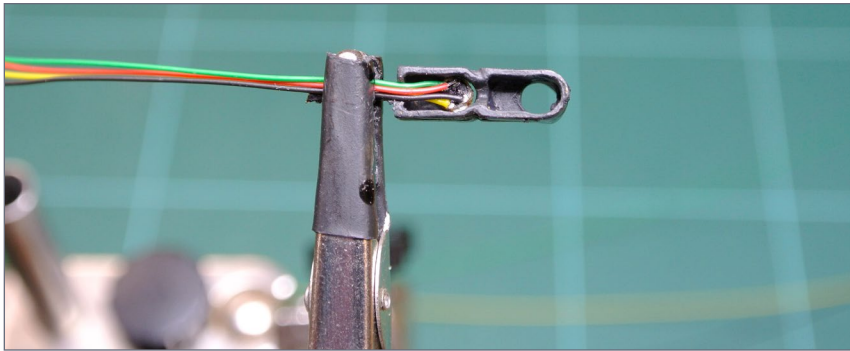

22. LED in position in the housing (bottom LED).

Once the fit of the LED is correct the four (4) wires need to be bent down and threaded through the small hole in the base. Remember to install the bottom LED first.

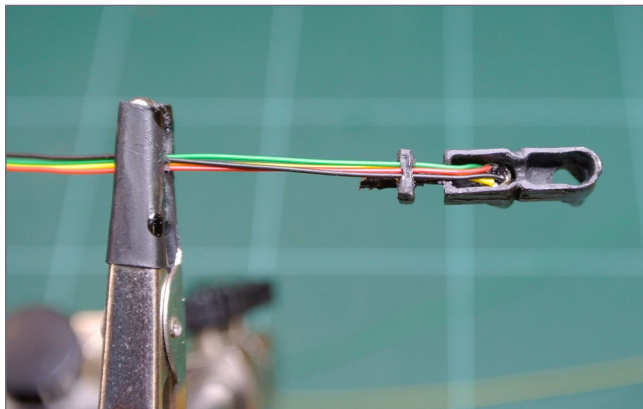

23. Wires threaded through the base hole.

Secure the LED in place with a small amount of CA around the edge of the PCB.

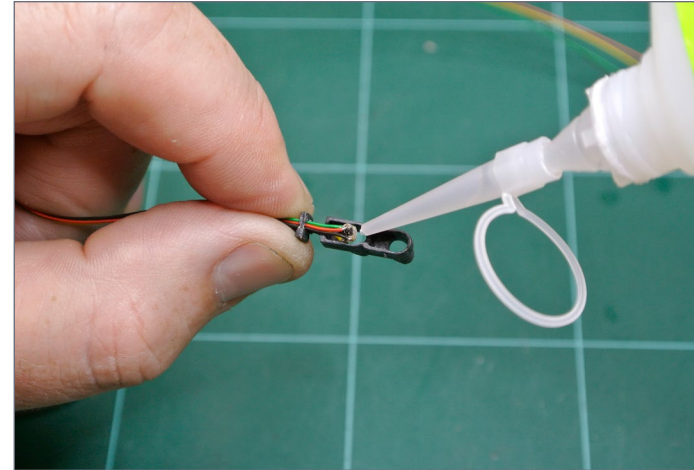

24. LED being secured with CA.

Next, install the second LED and thread the wires through the base hole. Also secure the second LED with a small amount of CA around the edge.

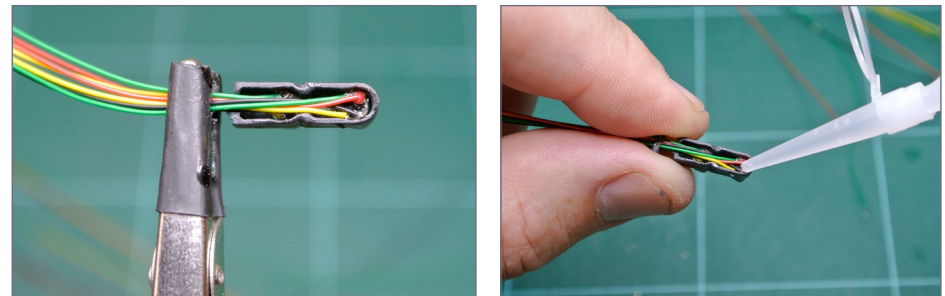

25. Installing the second LED.

STEP 6: FILLING THE HOUSING CAVITY

To fill the remaining cavity in the housing, I used Liquid Electrical Tape (LET). TOMAR also uses LET from the factory with the originally installed LEDs. This LET helps secure the new LEDs in place and insulates the wires and PCB pads from the brass housing.

I placed a small amount of LET into the cavity so that the level is just above the housing. As it dries (usually about 5-10min) the LET will settle and smooth out. If required, I apply a second coating to finish the LET off flush with the back of the housing.

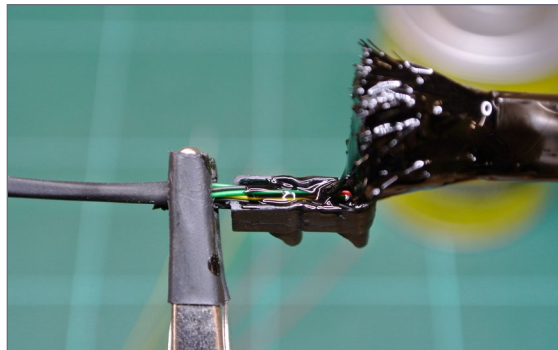

26. Applying LET to the housing.

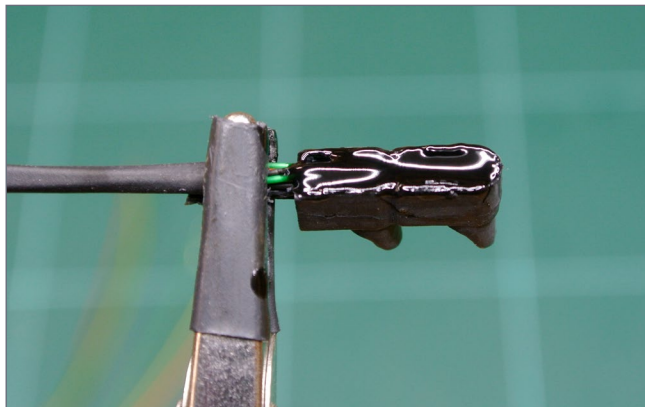

27. Finished LET in the housing.

STEP 7: FITTING RESISTORS

Due to the brightness of the LED's, I installed a 4.3K ohm resistor on both the red and green aspects, and a 1K ohm resistor on the yellow aspect. This brings the brightness down to a level perfect for search-light dwarfs.

First, I trim down the resistor to about 5/16" (8mm) and solder the LED lead wire to one end.

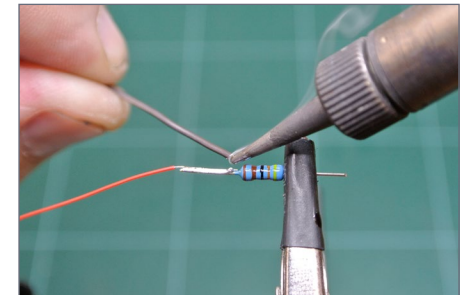

28. Resistors I use, and soldering the resistors to the LED lead wire.

The finished dwarf signal with the wires and resistors soldered on.

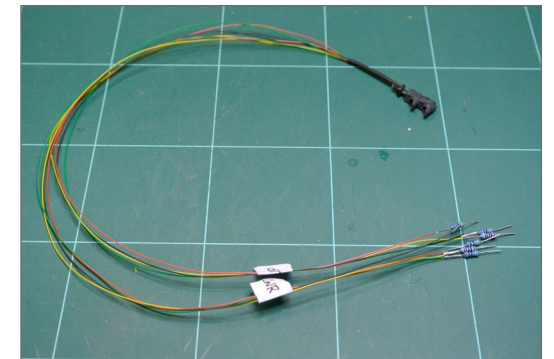

29. Completed dwarf signal with wires and resistors.

STEP 8: FINISHING OFF THE DWARF SIGNAL

To finish off the dwarf signal, I repaint the entire housing Grimy Black, including the wires coming out the bottom through the base plate. At this stage I also check to see if the base stem and plate are straight on the vertical plane: being brass these can sometimes be bent and require straightening.

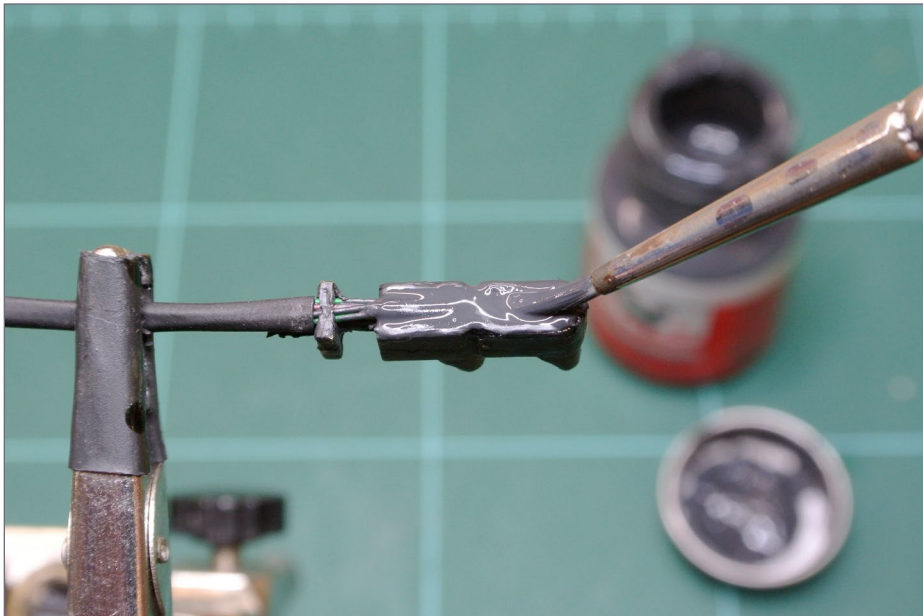

30. Painting the signal housing with Grimy Black paint.

STEP 9: WIRING THE SIGNAL FOR OPERATIONS

To complete the installation, the signal needs to be connected to a suitable piece of hardware to either drive the aspects from the board, or through a computer program. On my layout, I am using Digitrax SE8C signal driver boards via JMRI. The physical connection from the signal to the SE8C is via a Digitrax TSMK connection board and ribbon cable.

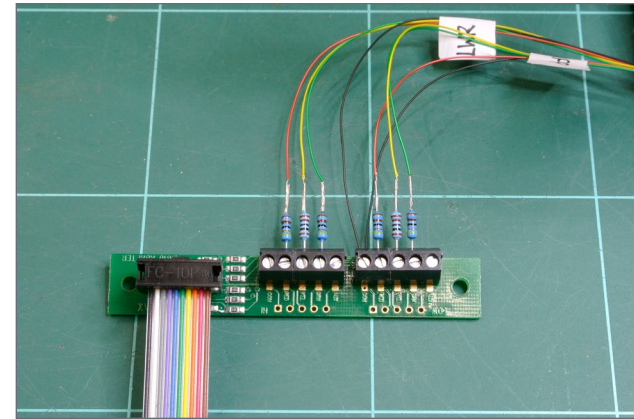

31. Digitrax TSMK with ribbon cable and resistors connected.

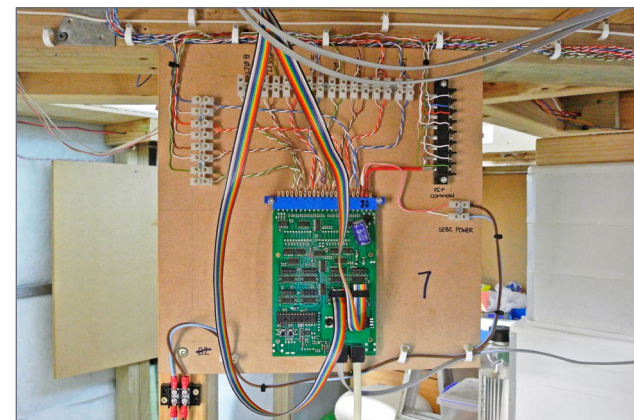

32. Ribbon cable and SE8C in place under the layout.

STEP 10: USING THE SIGNALS DURING OPERATIONS

The signals on the JL&T Railroad use the Conrail 1988 Aspect Chart as the basis for the signaling system. Fortunately, the JMRI program on Panel Pro uses the NS2008 Signal Chart, which is the same.

The following video shows some of the available aspects:



33. Video showing the signals in operation.



[Click here to rate or comment on this article](#)



34. Completed dwarf signal in place on the layout.

Conclusion

I find the overall ease of installation and the small size of these tri-color LEDs allow fitting them into most signals that use a 3mm T1 LED. The prototypical aspect colors are fantastic and make this LED a great upgrade for your dwarf and mast signals.

At some time in the future I hope to delve deeper into my layout's detection & signaling installation.



[Click here to rate or comment on this article](#)

INSTALLING TRI-COLORED LEDs | 23

JASON MILLER



Jason lives in Diamond Creek, Victoria in Australia. He has been building his HO scale layout for the past seven years and attributes his start to his wife Linden, who said that he needed to get a hobby! What a wonderful wife...

Jason is a professional firefighter and has been doing this for 14 years, when not at work he enjoys spending time with his family. Jason and Linden have two boys, Lachlan, 9,

and Toby, 6, who show a keen interest in the hobby.

When not working on the layout and spending time with the family, Jason likes to work in the garden of the family home, and he also enjoys having a coffee with the family at one of the local coffee shops.

The layout is HO Scale and is based on the Reading Lines between the early to late '70s.



[Click here to rate or comment on this article](#)

WISH: Shadow expert home layout builders and learn their best tricks ...



MODULE 1
2.5' X 7'

MODULE 3
2' X 7'

GRANTED:
In the 2017 TMTV season,
we do just that.

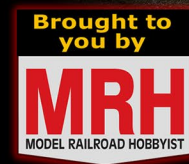

TRAINMASTERS.TV
Don't miss out: Click now and join in!

Benchwork provided by



modelrailroadbenchwork.com

ONE MODULE CHALLENGE

Grand prize winner

BY GREG BAKER

Central Oregon and Pacific in HO Scale ...

EARLIER IN MY RAILROAD CAREER I WORKED for the Central Oregon and Pacific Railroad (CORP) out of Eugene Oregon on the old Southern Pacific Siskiyou line. It was an exciting time to be working for the railroad, as business was booming and things were looking up for the railroad in general. One of the jobs worked on occasion was a local job out of Eugene called the Yoncalla Switcher. This job primarily worked from the Union Pacific Eugene Yard, taking care of the industries along the way, usually completing the work at Latham, a station just south of Cottage Grove. OR.

Model Railroad Hobbyist | April 2017 | #86



[Click here to rate or comment on this article](#)

I have thought that a railroad based on the switching activities of this job would be interesting and fun. Although most of the switching was straightforward, there were always a few obstacles to overcome. This job usually started work in the afternoon, working late into the night. I had the opportunity to grab a number of photos of the train working, both from the train and from trackside. As for the job itself, we would go on duty in Eugene and then collect traffic in the yard. Once the train was ready to depart, we would operate over the Union Pacific Railroad to Springfield Junction where we would get on our own railroad.

The first industries to switch were right there at Springfield Junction, and they included Far West Steel, Williams Bakery, and PW Pipe. Traveling south on the line the next station is Goshen which had Cone Lumber and Goshen Reload as regular customers. There was a spur for the Bonneville Power Administration which I spotted once and sometimes was used to tie up the power if it was not going to make it back to Eugene. The next Station was Creswell which had a passing siding and Bald Knob Lumber. Bald Knob was interesting because it had a small bridge that would not support a locomotive, so you had to hold onto extra cars when switching them. The next station was Walker, which was used to hold cars for spots on the south end, and loads to be picked up on the north end. Between Walker and Cottage Grove were Westwood and Willamette industries, Westwood was a regular customer, while Willamette Industries

ONE MODULE CHALLENGE | 3

was an infrequent shipper. Cottage Grove was the next station, and used to be a very active railroad location with an interchange with the Oregon Pacific and Eastern, along with a few sawmills. By 2000 this was just used to store cars. The next station was Latham, which was where the Weyerhaeuser facility was located and they consumed the most cars. The next station was Divide which was sometimes used to hold cars if Latham was full.

In looking at my list of industries and the logical way I would build the railroad I decided to start at the end with the largest customer, Weyerhaeuser. This would give me an opportunity to do some switching, model a sawmill and get a good feel for the direction I would want to take the layout. Also if all I did was complete either side of the module it would make for a nice switching layout and backdrop for taking photos.

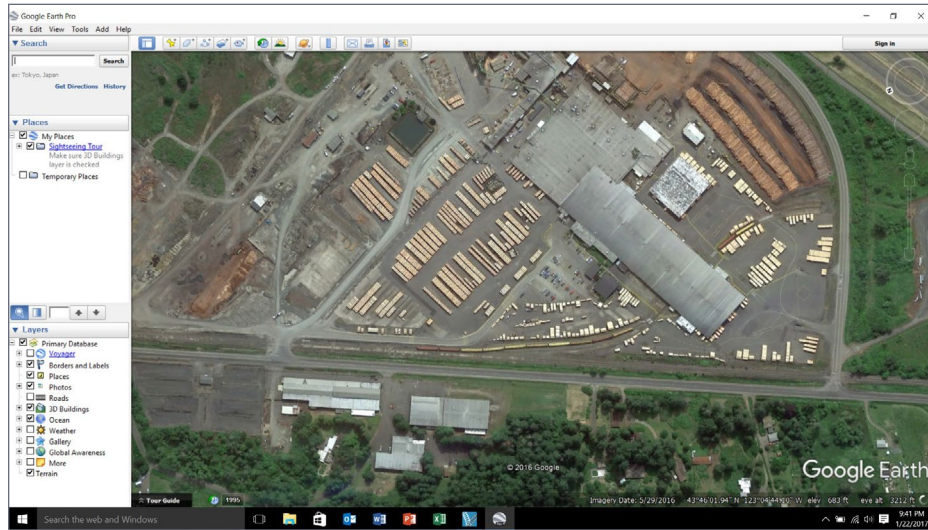

1. Weyerhaeuser aerial view.

ONE MODULE CHALLENGE | 4



2. Latham runaround.

With my general location selected I decided to focus on the main portion of the mill for this challenge. The main facility had a switch off the mainline that leads into a runaround, on the other end of the runaround the track entered into the mill and then went out the back side of the building. The facility held 14 centerbeam cars, and although pretty straightforward to switch did present some challenges. The other part of the facility was where they unloaded logs, these logs originated on the Portland & Western (PNWR) and were handed off in Eugene.

This traffic operated on a unit log train between Eugene and Roseburg and would spot many of the locations on the route. Often they had more inbound loads than the track could hold so the Yoncalla job would pull the empties and re-spot the loads at night so they were ready to go in the morning.

Upon arriving at Latham, we would gather up all the loads and move them to the mainline. The facility would leave 10 loaded

ONE MODULE CHALLENGE | 5

cars on the lead and four loaded cars sitting out behind the building. Once the loads were moved we would then spot the empties. When spotting the facility we would shove through the building leaving two cars outside in the back, we then would pull back into the building spotting two cars inside, the remainder of the cars were left on the lead.

The mill would then use a Trackmobile to move the cars around and load them two at a time inside the building. Once they were finished they would place the cars on the other track next to the lead and cars outside the building. Since I would not have room for a 14-car spot, I felt the same moves could be accomplished with a five-car spot. Like the prototype, I would gather the loads and get them out of the way. For spotting, I would leave one car out back, one car on spot, and the remaining three on the lead. Randomly assigning the traffic to Roseville or Hinkle and blocking them accordingly would add another level of challenge. To



3. Weyerhaeuser Trackmobile.

ONE MODULE CHALLENGE | 6

have some other work to do, spotting the log dock would be the next move. This again would be reduced from the prototype to three cars. This would be an easy switch by pulling the empties and replacing them with loaded log cars, but it adds some interest to the module.

The module itself would be built out of 3/4" plywood ripped into 3" sections. These would be assembled into a self-supporting framework with glue and brads. It could easily be worked on in the garage or other area of the house until it was ready to install in the room. The first module would be 18" x 72", and would include a 24" Masonite backdrop attached to the back side. Since this would be the first part of a room-filling layout, I would set the

ADVERTISEMENT



Announcing
Motrak Models New Structure Kit
HO Scale "The Tool Shed"

CHECK
IT OUT!



Website: motrakmodelsusa.com
Email: info@motrakmodelsusa.com

ONE MODULE CHALLENGE | 7

layout height at 50" to provide space underneath for other things in the room. This also is a comfortable operating height for me.

The module would be prepared for wiring beforehand by drilling holes through the cross members prior to assembling. I would drill four holes, one for each bus that would need to run through the layout. To support this part of the layout, I would use heavy-duty 18" wall brackets available at hardware stores. These would then be anchored into the studs in the wall, or I would use appropriate wall anchors rated well above the weight of the module. The module would then be screwed into the wall bracket, so if it needed to be removed it would be a matter of just unscrewing the module and pulling it down. Each subsequent section would also be screwed together for ease in future moving.

Track would be HO scale code 83 Micro Engineering flex track and Walther's Shinohara turnouts. Switches would be operated by N scale Caboose Industries ground throws. I like the feeling of throwing the switch trackside instead of pulling a handle or pushing a button on the side of the layout.

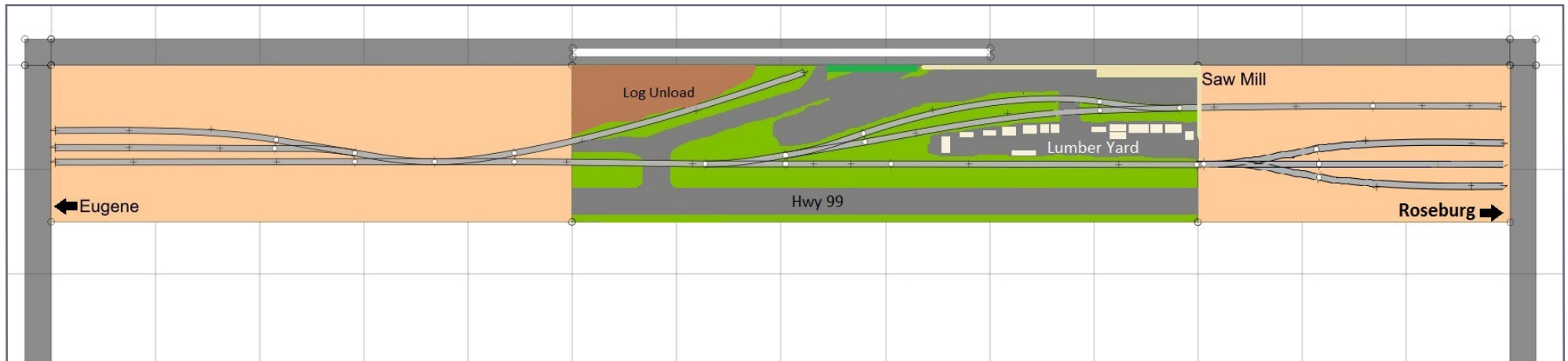

4. Initial module layout.

ONE MODULE CHALLENGE | 8

Scenery would be relatively simple, and with an almost solid plywood top there would not be much need for other materials. I figured I could use some closed-cell foam and Sculptamold to make any changes in elevation.

For structures, I would use a Walther's truck wood chip loader. I would scratchbuild the main part of the mill from Evergreen styrene. I would also use sheet styrene for the roadways around the building, and would surround the grounds with chain-link fence. The stacks of lumber would be made from plywood for the background; for the foreground I would use a mix of Jaeger loads and Grand Central Gems loads with the Weyerhaeuser logo.

I would wire the module for Digitrax DCC and would be able to plug into each module as it is added. I would also include a track bus and accessory bus to provide power to the layout. I would also plan to have a signal system on the layout and would set up the layout with the Modular Signal System (modularsignalsystem.info) to allow for block signaling in the future.

ONE MODULE CHALLENGE | 9

The support module on either side would essentially be additional modules built in the same style as the main module, but only to a level to allow operations.

Some other interesting things to consider beyond the Yoncalla Job and the unit log trains are the daily haulers. The Roseburg Hauler worked south with at least five Union Pacific six-axle units. On Sundays CORP power was added to the train to head south; this job generally worked at night. The Eugene Hauler ran during the day with the train split in two, operating with manned helpers between Roseburg and Eugene. The head end of the train was all the Roseville-bound cars, and the rest of the train would be for Hinkle. The trains would split at Springfield Jct. where a Union Pacific crew would take the Roseville train south, and a CORP crew would take the Hinkle traffic into the Eugene yard.

The Siskiyou line was at an interesting time when it came to signaling. We had some of the newest and oldest signals operating at the same time, and I think capturing this on the future layout would be interesting. Between Eugene and Divide was a mix of single-head block signals, tri-lights, and semaphores.



5. Goshen midtrain of the Eugene hauler.

ONE MODULE CHALLENGE | 10



6. Old semaphores, and brand-new signal lights.

The territory was governed by Track Warrant Control and an Automatic Block Signal system (TWC-ABS). This would provide some interesting operations in following the rules governing TWC-ABS, and would add another level of interest to see the mix of signals. At this time CORP was also in the process of adding Electro Code signals to the line to replace the old system that required all the telephone lines and expensive upkeep of the semaphores. The early 2000s were the last stand for many of those signals, and I would like to capture that on the layout.

For me this was a great walk down memory lane, seeing these photos and remembering how things were accomplished. As for the module, I think that the mill itself would be an interesting standalone module, along with the possibility of some switching operation. I also feel it would be good motivation to continue working around the room to add in additional operation once the first section has been completed.

Combo Right Clamp™

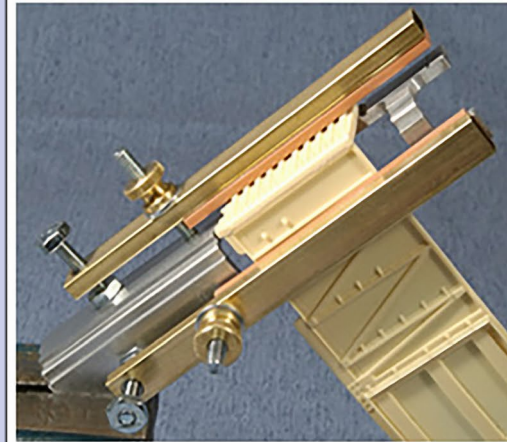

Combo Right Clamp™ with cast resin boxcar

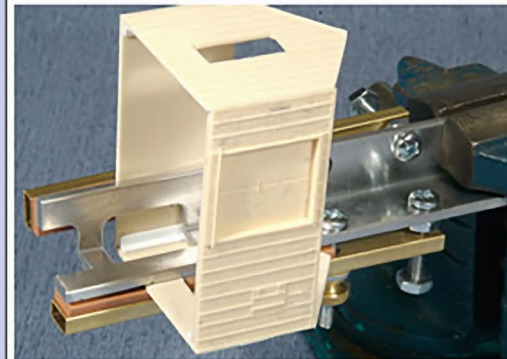

Combo Right Clamp™ with Wolf Design Pump House

Click here for all our products ...

Tools for Modelers

Coffman Graphic Solutions Co.
1500 River Circle, Richmond,
KY 40475-7907

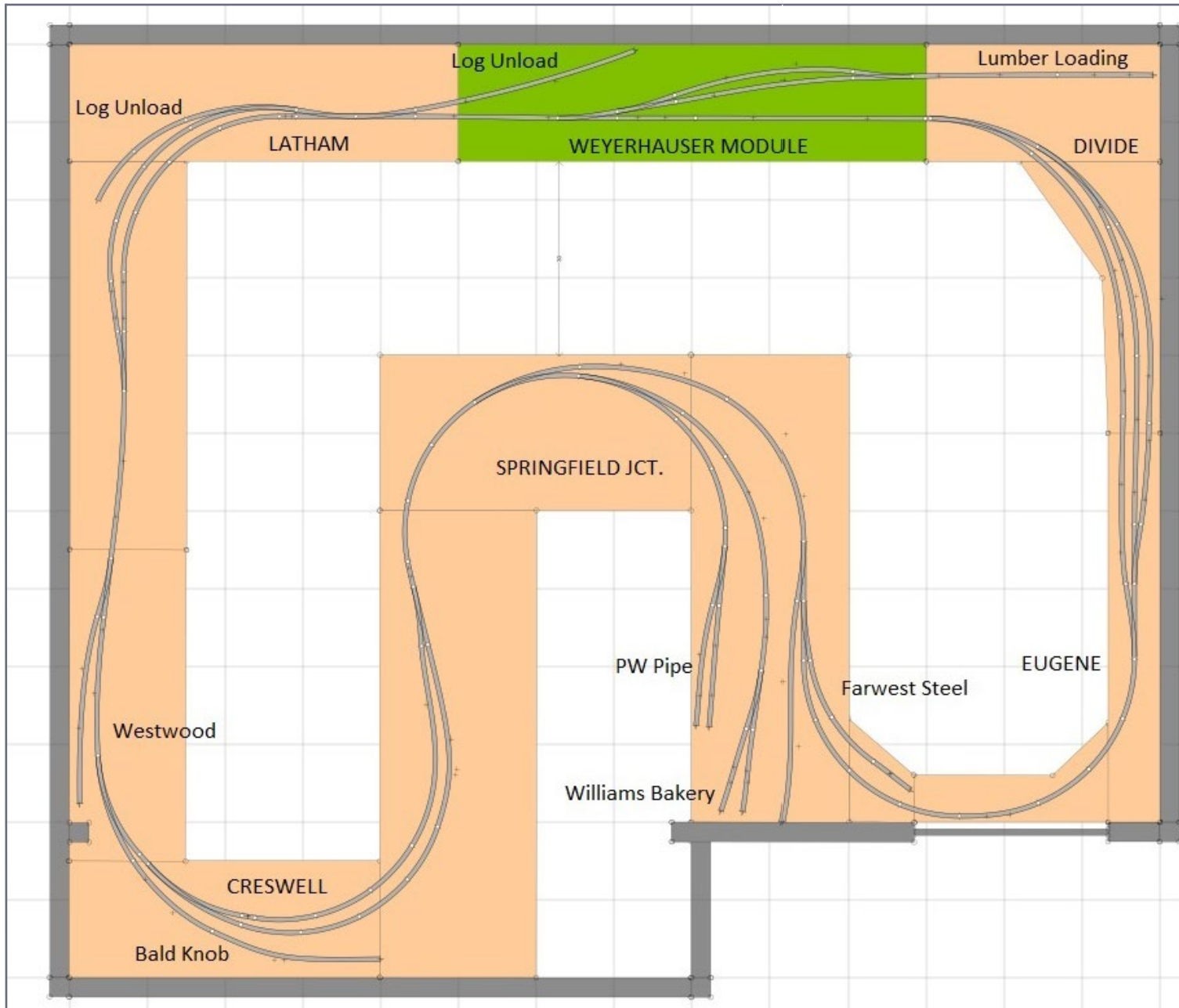

7. Final layout.

BILL OF MATERIALS

BENCHWORK

3/4" birch plywood 4'x8':	\$ 45.00
1" Foam (pink or blue) 2' x 2'	\$ 8.00
Heavy Duty wall brackets (6)	\$ 10.00 ea.
1/8" Hardboard 4'x8' sheet	\$ 15.00

SUBTOTAL \$128.00

ELECTRICAL

Red 14 AWG stranded wire 25 ft	\$ 7.00
Black 14 AWG stranded wire 25 ft	\$ 7.00
Blue 14 AWG stranded wire 25 ft	\$ 7.00
White 14 AWG stranded wire 25 ft	\$ 7.00
Red 24 AWG stranded wire 25 ft	\$ 4.00
Black 24 AWG stranded wire 25 ft	\$ 4.00
Digitrax LocoNet Cable Maker Kit	\$ 45.00

SUBTOTAL \$ 81.00

TRACK

HO scale cork 3' section (3)	\$ 1.60 ea.
N scale cork 3' section (3)	\$.99 ea.
Micro Engineering Code 83 flex1 pack	\$ 36.25
Walthers RH Switch # 6 (2)	\$ 29.99 ea.
Walthers LH Switch # 6 (1)	\$ 29.99 ea.
N scale Caboose ground throw (3)	\$ 3.45 ea.

SUBTOTAL \$144.34

SCENERY

Flat brown paint (1 pint)	\$ 10.00
Rustoleum Camouflage Brown	\$ 5.00
Sculptamold (3lb. Bag)	\$ 8.00
Evergreen .030" styrene sheet	\$ 7.00
Evergreen .060" styrene sheet (2)	\$ 7.00 ea.
Woodland Scenics static grass (2)	\$ 12.99 ea.
Woodland Scenics ground cover (3)	\$ 3.99 ea.
Misc. other scenery	\$ 50.00

SUBTOTAL \$121.95

STRUCTURES:

Walthers sawmill outbuildings	\$ 49.98
Sawmill (scratchbuilt)	\$ 50.00

SUBTOTAL: \$ 99.98

DETAILS

Jaeger Weyerhaeuser loads (2)	\$ 20.00
Grand Central Gems Weyerhaeuser loads (2)	\$ 20.00
Misc. details	\$ 50.00

SUBTOTAL \$130.00

GRAND TOTAL \$705.27 ■



**Click here to rate or
comment on this article**

ONE MODULE CHALLENGE | 15

GREG BAKER



Greg Baker has been “seriously” model railroading since 2000, but as long as he can remember, he has been fascinated by trains.

Greg’s main interests are the railroads of Central Oregon in 1968, focusing on the SP&S, Great Northern, and Union Pacific along the Oregon Trunk. He is also interested in the City of Prineville Railway and its connection to the Oregon Trunk.

He currently resides in Lewiston, Idaho, with his wife Tiffany, 4-year-old daughter and 8-year-old son, as he continues his career in railroading. He is actively involved in promoting Free-mo, and has created an Idaho Free-mo group. ■

ALSO CHECK THE BONUS CONTENT THIS MONTH!

Greg sent in a lot more prototype photos and docs to go with his submission than we could publish, so we’ve put that extra material in this month’s subscriber bonus content.

[Click here to check it out!](#)



[Click here to rate or comment on this article](#)

NEW!

TMTV Season 2 DVDs and downloads



DVD
~~\$36.99~~
\$29.99

DVD
2 disks

Download
~~\$19.99~~
\$14.99 9 files



DVD
~~\$36.99~~
\$29.99

DVD
2 disks

Download
~~\$21.99~~
\$16.49 12 files



DVD
~~\$44.99~~
\$31.99

DVD
3 disks

Download
~~\$24.99~~
\$19.99 14 files



DVD
~~\$49.99~~
\$33.99

DVD
4 disks

Download
~~\$29.99~~
\$22.99 16 files

ALSO: The Complete TMTV Season 2 DVD set, volume 1 and 2 are now shipping!

SHOP NOW >>

**Model Railroad
Hobbyist Store**
store.mrhmag.com

CONVERTING TO A NEW DCC SYSTEM

BY ERIC MILLER

1. After evaluating his railroad's needs and performance, Eric Miller converted his Southern Pacific Santa Fe Meadow Sub from one DCC set-up to another.

Radio control developments and op session experiences lead to a checklist for change ...

LAST FALL, I CONVERTED THE DCC SYSTEM ON my medium-sized layout from Digitrax to NCE¹. The project seemed a little daunting at first, but the actual conversion was rather easy. I want to share my reasoning behind the switch in DCC operating systems and my experience converting the layout from one DCC system to a different one, so that other layout builders might benefit from it.

¹ The main message with this story is don't be afraid to think about switching DCC systems if your needs change. The fact Eric went from Digitrax to NCE is incidental to the message here. To see that changing DCC systems need not be scary is helpful, we feel. Please don't read this story as being anti-Digitrax – if you get that then you're getting the wrong message! We'd love to also publish an article about an NCE system owner who felt LocoNet was compelling and converted to Digitrax. Any takers?



[Click here to rate or comment on this article](#)

My DCC system wish list

I started building my layout in March 2010, and shortly after added the DCC system. After running the layout for more than six years, I had learned more about DCC operations and became comfortable fixing issues myself. I also became more familiar operating with other DCC systems. Essentially, I matured over this time and figured out more specifically what I wanted out of a DCC system.

Last fall I made a wish list that helped me decide whether to switch and how to proceed with a new DCC system.

- The system should have a robust radio system so operators can use handheld throttles or cabs without being tethered to the layout.
- The system should have a throttle or cab that is easy for visiting operators to use. I don't want to require operators to bring anything to use. All the tools should be at my layout, and it should be easy to figure out so operators can focus on operations. I wanted a digital display on the throttle and a simple knob to turn.
- Programming locomotives should be simple. I want to use JMRI Decoder Pro on my computer to set up all the functions on locomotives.
- I want a system that is supported by the company and has good customer service.
- The new system should have characteristics similar to my old system – be able to support my locomotive fleet, run multiple crews with throttles, split into four separate power districts, etc.



What started the questions

A number of events led to thinking about a change. The primary cause was getting more into operations. After I started the layout, I changed my operating scheme several times. It took a good five years until I settled into my current plan. I had held a few operating sessions over the years, but never got very much into it. My goal last year was to hold three operating sessions, and to increase this by one operating session each year until I was holding a session every two months. This got me running the layout

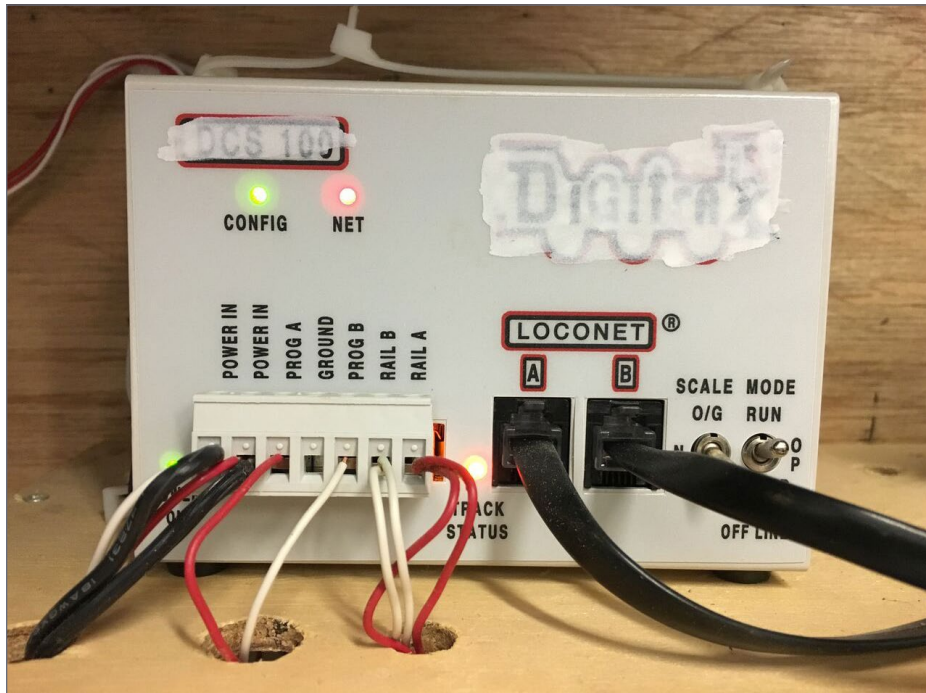

2. This is the Digitrax DCS 100 command station right before I replaced it with the NCE Power Pro command station. I took this photo so I could remember how the wires had been connected. I also compared the wiring layout with the PH-PRO-R to make sure the same connections would work.

more often and more seriously, and led me to meeting more modelers in the area and getting to know different DCC systems.

I used Digitrax from March 2010 until August 2016. I chose my first system because a good friend, Chuck Shell, was a Digitrax retailer and knew the products very well. Almost everyone in the informal Tuesday night layout group I was involved in used Digitrax. Since this was my first foray into DCC and I had very limited experience, it was obvious that I should go with Digitrax so to have assistance nearby in case any problems surfaced.

Digitrax Duplex

I was the first layout in my group to use the new Digitrax Duplex system – everyone else had simplex (my friend Chuck had both on his large layout and never got the duplex system to work to his satisfaction). So Chuck set my system up very similar to a simplex layout, with the UP5 panels for plugging in throttles spread evenly throughout the layout fascia.

I bought the Super Chief system, which came with the DCS100 command station, a UR92 Duplex radio receiver, and a DT402D throttle. I bought a PM42 to separate the layout into four power districts. I later purchased three UT4D duplex radio throttles for operating sessions, since they are smaller, simpler throttles. I connected the system to my computer using a Loco Buffer with a USB connection and bought a SoundTraxx PTB-100 to program sound-equipped locomotives.

Over time, the system worked very well and I had no major issues. One of the throttles I bought in 2011, however, had a very weak radio signal. I chalked that up to a battery problem, as I didn't purchase reliable rechargeable batteries until late 2015, when I prepared to start regular operating sessions.

The big issue I had initially was that the system kept shutting down from short circuits when operating, and it wouldn't

CONVERTING TO A NEW DCC SYSTEM | 5

recover from these. A good friend, John Parker, turned me on to the DCC Specialties PSX circuit breakers, so I installed PSX-4 units and my problem went away.

Fast-forward to early 2016 when I had my first real operating session. I gave a crew the problem throttle but it did not work well for them. They used my larger DT402D throttle for the session.

One of the operators who had Digitrax on his layout suggested that I fill out the Digitrax repair form and send it in. I did this right away, since I wanted it back in time for my next operating session that summer; however, I did not get it back until the end of summer, and the throttle still had issues.

It was during this time I realized I no longer had to lean on my layout group for DCC help, and I started to do more of my own troubleshooting on DCC problems. Getting more into operations, including operating on other layouts, led me to learn about other DCC systems, particularly North Coast Engineering (NCE). In talking with other people in the area, it seemed like NCE was a system I should try. Since I had a smaller layout, I thought it would be easy and not too expensive to switch.

After trying to update firmware on my UR92 radio receiver “bricked” the receiver, I was left with a layout that did not operate. I planned to have another operating session before the end of the year, so I had to act quickly to make a decision to get my layout back up and running.

Reevaluating the DCC system

Prior to this, I had been thinking about switching DCC systems. Before making a change, I took a step back and re-evaluated picking a DCC system for my layout as if I were starting from scratch. I wanted to see if I would still come to the same conclusion. I figured that I had three options:

CONVERTING TO A NEW DCC SYSTEM | 6

- Stick with the Digitrax duplex system and send the UR92 in for repair.
- Convert to the older Digitrax simplex system, which my friends claim has better radio reception. For this, I could buy throttles and a receiver on eBay.
- Convert to a completely different DCC system like NCE

Then I created the wish list I shared earlier in this article. If I came up with a dream DCC system, what would it look like? The robust radio system was at the top of my list. Also important was having good customer service.

Ultimately, I decided to sell my Digitrax equipment and switch to NCE because it met the goals I had developed after having more prototype ops experience. Going to the Digitrax simplex system

Almost 40,000 have read this MRH forum thread - **HAVE YOU?**

Share your weathered rolling stock, Please!

Sat, 2012-03-24 12:34 — Bluessman Locos and rolling stock Locos - Rolling stock (general)

Share This

I am hoping some of you will share some pictures of your weathered rolling stock. I always love to see other peoples work and of course learn something new!

Gary

Athearn Blue Box

Thu, 2012-03-29 04:56 — Tom Patterson

Here's a boxcar that I built in 1965 based upon a small photo in MR.

Read now

CONVERTING TO A NEW DCC SYSTEM | 7

was tempting, but I finally elected to go with NCE instead. A different set of questions and requirements could have produced a different decision, but I was confident I was headed in the right direction for operating the Meadow Sub.

Choosing the equipment

I bought an NCE PH PRO-R. It comes with the Power Pro command station, RB-02 radio, Pro Cab throttle, and one NCE panel. This seemed like a good replacement for my current Digitrax Super Chief system, as it had similar abilities and would be the closest to what I already had while filling my wish list needs. I decided to buy my operator throttles later. Selling all my Digitrax equipment paid for the PH PRO-R starter system.

The easiest part was replacing the DCS100 command station with the new NCE Power Pro command station. I simply disconnected all the wires from the DCS100, swapped command stations, and plugged the wires into the Power Pro. I reused the Digitrax AC adapter, since it was rated at 5 amps and 15 volts AC, which was required for the Power Pro. Then I turned on the layout – everything worked fine – I could run trains again!

Customizing the NCE installation

After the initial installation, I still had to do some customization to get the system to work the same way it had with my old system, and to complete the items in my wish list. This included:

- Connect the system to my computer so I could program locomotives with JMRI.
- Relocate the fascia panel closer to my computer and program track.
- Relocate the RB-02 radio to a more central location in the layout.

This required me to purchase some more material. I held off buying these items until I knew more about the system. I bought more

CONVERTING TO A NEW DCC SYSTEM | 8

cables, RJ12 connectors, and another connector panel. (Now that I have been using the system more, and never connect the throttles to the panels, I probably didn't need the additional panel.)

I made one initial error. I thought I needed an NCE-USB Interface similar to the LocoBuffer to connect to my computer. I later

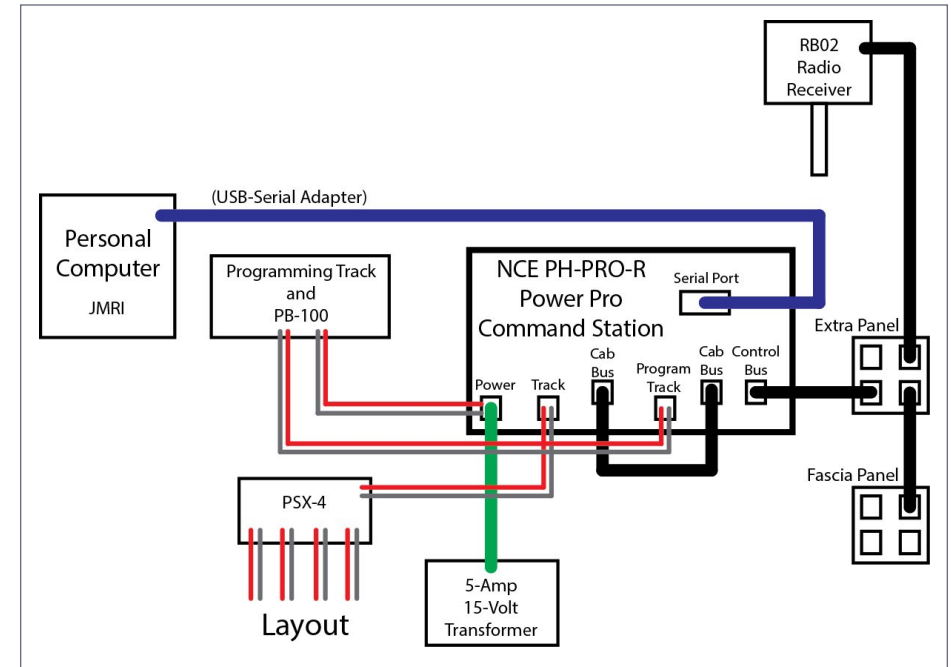

3. This is a basic illustration of how the NCE system is set up for my layout. If I had to do this all over again, I could get by without the PB-100 and programming track, since I program everything on the main track. I could also do without one of the fascia panels, since I never use them. I would locate the computer and command station closer together – I needed almost 50 feet of USB cable to connect to the serial port on the NCE Power Pro. To overcome USB limits, I ordered a 30' active USB repeater cable and combined that with a 16-foot USB-serial port cable.

CONVERTING TO A NEW DCC SYSTEM | 9

I learned that the NCE-USB Interface is for connecting to the Power Cab. For my Power Pro, I just needed to connect the computer to the built-in serial port on the command station. So I ended up selling the NCE-USB Interface and purchased a USB-Serial DB9 cord (with an FTDI chip).

As I became more familiar programming with JMRI on NCE, I learned that using the mainline programming is easy and much faster than before. Now, with a new locomotive, I program the address from 3 to the new number using the NCE Pro Cab; I do everything else on JMRI in mainline programming mode. I am seriously considering removing my programming track, since I never use it.



4. Here is the RB02 radio receiver in the spot previously occupied by the UR-92. I read that the best place to put the RB02 is in the center of the room, on the ceiling, and turn it upside down so the radio waves spread out like a mushroom and reach all operators. This placement passed the test of the first op session. The opening at the bottom of the panel housed a fast clock display that was relocated.

CONVERTING TO A NEW DCC SYSTEM | 10

I kept the LocoNet cables I used with the Digitrax system, but had to change the connectors on the end because they are reversed on the NCE system. I cut off the old connector and then added a new connector with it flipped over so that the blue wire is on the right when looking on the top (with the plug lever).

Reusing the LocoNet cable allowed me to locate the RB02 radio base station where the UR92 was before, in the center corner of the layout room, using the same console I had for the UR92. The bonus is that I don't need a wall transformer for the RB02.



5. Here is the one fascia plug-in panel I installed, just to the left of the Pro Cab throttle. I haven't used the panel since I installed it, and looking back, didn't really need one here. But I guess it's good to have a backup plan.

I gave the new RB02 location several good tests around the layout room and never lost my train. I tested it behind the stairwell on the other side of my workbench and facing away from the radio. Then I went upstairs and tested it all over the house, and I could always hear my train. The NCE radio system is one of the best features of this DCC system.

With that, I had finished my customization. One final note on the panels: I purchased the extra panel to install right by the command station. This allowed me to split the cable right at the command station, with one cable heading to the RB02 and the other cable heading to the NCE fascia panel. I had planned to connect the NCE-USB Interface to the fascia panel, but this won't be used for now. However, it's now designed to allow future expansion, and I can easily add more cables if I need to.

Getting ready for ops again

I still had some things to do before holding another operating session. I needed to buy some small throttles for the operators, and went with the Cab06r. This is the newest NCE radio throttle, and has a small LED screen so operators can see the engine or consist number that is selected.

If I could do it over again, I would have bought the throttles with a potentiometer instead of an encoder, so operators can easily tell when the knob is turned all the way down to zero. I have recently adjusted my locomotives to minimize the momentum and speed, which works well for my switching branch line and should make the throttles easier to use.

I thought about using something else for throttles, like smart phones, which seem to be popular among layout owners. One idea in particular that intrigued me was having the operators use their own phones when they come to operate. Then I wouldn't need to buy any more throttles.

The more I thought about this idea, it went against my list of goals because it would involve requiring guests to bring their throttles, and it is also not a simple throttle with a knob.

Additionally, this idea would involve me setting up the wi-fi for this to work and would bypass the advantages of the robust NCE radio. Therefore, I decided to stick with the tried-and-true NCE cabs and throttles.

Battery change

The new throttles require different rechargeable batteries. The Digitrax throttles use 9-volt batteries and the NCE throttles use AAA batteries. I bought new rechargeable batteries and a new charger from Thomas Distributing, and sold the old equipment on eBay.

Layout tours – Trackwork – Structures – New
Plann
– Humor – Contrarian Opinions – News
DCC
Ballast – Multi-deck designs – Small
ering – First looks – Rolling stock
guidelines – Clickable ac links – Video – Operat
Prototype modeling – Lighting – MRH forum – In
active reader feedback – Questions Answered
– Upcoming events – Liners – Buil
signs – I
Scenery
tuning – The Tool Shed – Layout owner interv

Model Railroad Hobbyist magazine™

YES, subscribing MATTERS!
(even though it's free)

**It helps MRH get more
advertisers**

Click here to subscribe!

One of the best things about NCE throttles that I learned is that they “time-out” with inactivity, and actually turn off. I don’t need to take the battery out every time I am done operating and then put it back in when I want to run the trains. Another great aspect of the NCE throttles is they have a jack on the throttle to plug in the cable when it is needed (which is virtually never for me), and they don’t have a cable sticking out all the time.

Fast clock

I also needed to add a fast clock to the layout. I used to have a Logic Rail LocoNet fast clock, which worked with my Digitrax system. I decided to sell it and convert to a different system.

Again, I went through my wish list to figure out if I still needed a fast clock, and what kind I wanted. I decided to go with a computer-based fast clock and am currently using the one on JMRI. This way, I can use any fast clock system that I can run on the computer, including web-based fast clocks.

For this new system, I purchased a 7-inch LCD monitor that is connected to my computer and is located near the center of the layout where my old fast clock was. Operators have two places to view the clock: at the dispatcher’s desk where the computer is, and on the other side of the layout. This was also a very inexpensive way to do the fast clock and cost about \$50 with all the equipment.

With the fast clock problem solved, I went to work covering all the open holes on the fascia where the Digitrax UP5 throttle panels were formerly mounted. I had eight UP5s. One hole was mostly covered by an NCE panel, so that left seven to fill. I cut some scrap hardboard into rectangles to fit, added some drywall mud, and repainted. My fascia is now less cluttered than before, which I really like.



6. I filled in the old UP5 fascia panel sites with hardboard and made custom SPSF graphics. The appearance is less cluttered, one of my main goals for the layout fascia.

With those additions, I was ready for my next operating session – two months later than I initially intended. I had three people running trains at the same time using radio throttles and everything worked great. All throttles held up and the batteries lasted through the 3.5-hour session.

Also important: I never had a short circuit during the session and never had to restart the layout. One thing I am considering before my next session is to purchase a backup throttle and backup batteries in case something happens to one of the throttles. This is also a chance to buy a Cab06pr with the potentiometer in case someone wants to use that.

Conclusion

It is nice to have a DCC system that caters better to the needs that have evolved over the years. I have been pleased with the

NCE Power Pro and the radio function thus far. As I mentioned earlier, this was an easy undertaking with only a few functions to replace (such as JMRI locomotive programming), so that wasn't hard to figure out.

One thing I am getting used to with NCE is that I don't have to restart the layout as frequently. I have met several modelers nearby with NCE systems, so if by chance something complex comes up in the near future, I have folks in close proximity who can help. That seems unlikely given my increasing familiarity with DCC and the fact that my NCE system has not had any issues so far.

I now have a DCC system that better matches my desires and will last me well into the future of the Meadow Sub!

ERIC MILLER



Eric got into model railroading with a Bachmann HO scale Santa Fe train set just before high school. He started working on a prototype-freelanced concept after that and never looked back.

Following a brief hiatus from modeling during college, Eric started developing the Meadow Sub about 10 years ago with construction starting in 2010 thanks to help from the local Tuesday Night Conspiracy modelers.

Eric lives in the Denver, CO area with his wife Heather and two daughters, Lindsay (5) and Courtney (2). He works at the Regional Transportation District and does the rail service planning and scheduling for the light rail and commuter rail lines, of which four new lines are opening or have opened within the last year.

ADVERTISEMENT



ROLLING ROADS

SPEEDOMETER For Speed In Real Time!



Analogue
or digital



CLICK HERE

Bachrus inc
RUNNING ON QUALITY

www.bachrus.com
Hannon, ON Canada



Click here to rate or
comment on this article



Click here to rate or comment on this article

Creating a 3D EFFECT FOR A CITY

BY BRUCE EDGAR

Multiple levels pack a lot of city into a small space ...

OUR CLUB, THE WEST PASCO MODEL RAILROAD Association (wpmra.org), moved into new quarters two years ago this last November, and we're going into our 3rd year at this location. (facebook.com/WPMRA) We started from scratch to create a freelanced layout with various industries and themes incorporated into three main lines.

I took on the task of building a city in a small section of the layout. Through much trial and error, with a lot of appreciated and welcomed comments, criticisms, and suggestions, I came up with what you see here.

One of the most common comments had to do with the original flat landscape of the section. It was suggested that we needed to create a vertical as well as horizontal area without hindering access from a staging area just to the right of the city.

I started out by using Styrofoam sheets (Home Depot insulation) on top of plywood for strength and flexibility. After the track was in place on the foam I laid butcher paper over the track. With the side of a crayon against the track, I traced the outline onto the paper. This was transferred to a matte board by running a knife through the paper.

To give the area an urban feel, I wanted the tracks to be embedded in the streets that crisscross the area I embedded track into the roadway by laying one sheet of matte board against the ties and another on top abutting the rails. I used joint compound to fill in the area between the rails. This will have a cobblestone look when I have time to carve it.

When the lower parts of the city were complete I started to look at how to add depth to the area. This was accomplished with flats, pictures and three-dimensional buildings.

I searched the web for pictures of buildings, in my case buildings from the 1940s and 1950s, and came away with hundreds of possibilities. Once they were downloaded into a project file, I cropped the pictures to eliminate unwanted parts. I put the cropped pictures into a Word document for sizing, coloring and



3D EFFECT FOR A CITY | 3

tinting using the tools included in the program. I don't have a photo editing program, so I used what was available.

Most of the pictures are copied and pasted side by side, allowing me to create the three-sided results you see here. Once the picture looks acceptable I print it in color and then paste it onto foam board using white glue. I cut along the outlines to bend the sides around to make the corners and insert triangles to keep the corners square.

It's a simple method that works well for filling up the space.



[Click here to rate or comment on this article](#)



1. The city as seen from across the yard. The building in [10] is at the top of the street under the flying airplane.

3D EFFECT FOR A CITY | 4



2. The city from a slightly different angle.



3. First placement of the buildings.

3D EFFECT FOR A CITY | 5



4. Alex Muir cast the stone walls.

3D EFFECT FOR A CITY | 6



5. A copy of the building on right flipped to show different direction on fire escape.



[Click here to rate or comment on this article](#)

3D EFFECT FOR A CITY | 7



6. I use picture frame clamps to hold corners square.

3D EFFECT FOR A CITY | 8

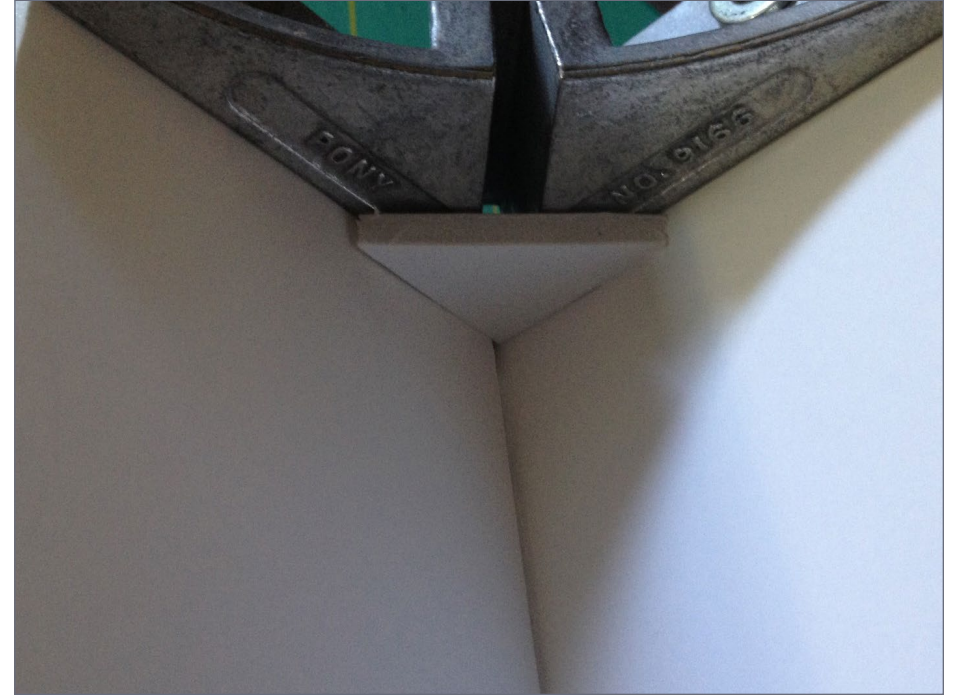

7. A triangle wedge keeps the building 'true' after glue sets.



[Click here to rate or comment on this article](#)

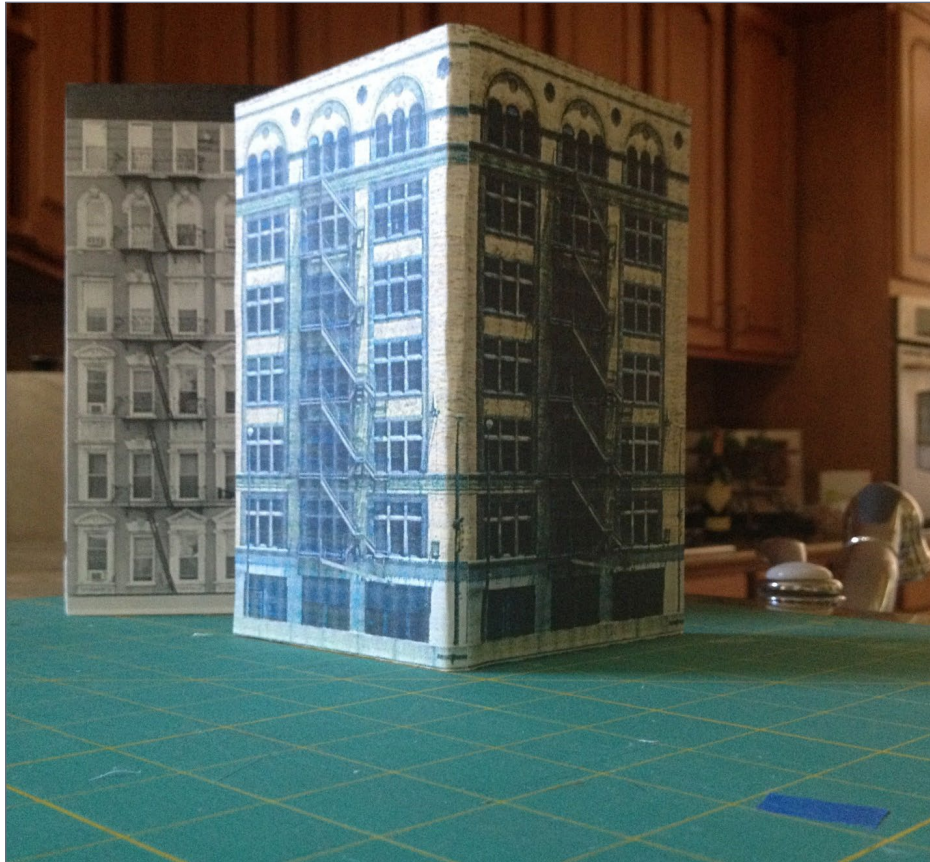

8-9. (Left and right) First building is done.

 [Click here to rate or comment on this article](#)

3D EFFECT FOR A CITY | 11



10. This is the building that appears under the flying airplane in [1]. From a distance it looks like streets go left and right at the intersection.

3D EFFECT FOR A CITY | 12



11. I trimmed this building and it sits at the far left in [1]. Street on right disappears behind another building.



[Click here to rate or comment on this article](#)

3D EFFECT FOR A CITY | 13

BRUCE EDGAR



Bruce has been interested in model railroading for the past 30 years and his goal is to build a freelance New England/Vermont Railroad layout based in the early diesel engine era. He enjoys building structures and scenery more than running trains and leaves the electronics up to the experts. His father worked for the Whiting Milk Company for many years, so when travelling on business or

pleasure, Bruce is always on the lookout for dairy related items. On a recent trip he found InterMountain's Whiting Milk refrigerated cars which brought back fond memories of his youth.



[Click here to rate or comment on this article](#)

Debug trackwork *like an expert.*

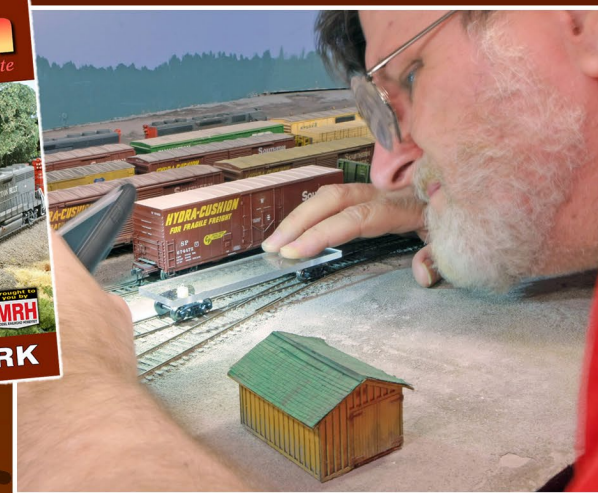
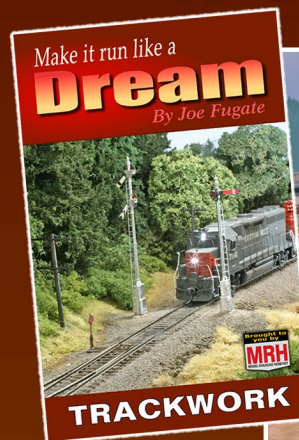

\$12.99

\$11.49

eBook

Also in
paperback

Click me to
LEARN MORE ...

Make it run like a
Dream
TRACKWORK: *By Joe Fugate*

From the MRH Store: store.mrhmag.com

Other books in this series: *ROLLING STOCK* (Mar 2017) and *LOCOS* (Sep 2017)

Bowser

Arriving late October
See Dealer

HO EMD F Unit Locomotives

Features: air hoses, windshield wipers, grab irons, coupler lift bars, operating headlight, window glass, can motor, flywheels, nickel silver wheels with RP25 flanges and knuckle couplers. Analog (DC) version features NMRA 21 pin plug for DCC, DCC/Sound version features LokSound Select Dual-Mode decoder which allows locomotive to be used on DC as well as on DCC layouts.

New for this run of F-units: Cab interior, Engineer & fireman figures, Hostler light where applicable, & Improved diaphragms

Road Names: UP, SP&S, NYO&W, Southern, Rock Island, Milwaukee Road, Bangor & Aroostook, Santa Fe, B&M, Jersey Central, Alaska Rail Road



Click here to check out the details for these and other great Bowser Products

MRHMAG.COM



SUBSCRIBE
(free)

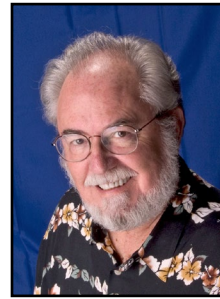

Model Railroad Hobbyist | April 2017 | #86

APRIL NEWS

column

RICHARD BALE and JEFF SHULTZ



Click here to rate or
comment on this article

NEW CLUB CARS



Providence Northern Model Railroad Club is selling a Bowser HO scale X31 wagon-top boxcar decorated for Rhode Island & Massachusetts.

Although the RI&M is a fantasy road, it is based on a railroad that existed in the late 1880s. The kit sells for \$18.00 and helps support the PNMR organization. To order visit providencenorth-ern.com.

NEW PRODUCTS FOR ALL SCALES

Speedwitch Media has released *Refrigerator Cars, Volume Three* in its series of *Steam Era Freight Cars Reference*

► THE LATEST MODEL RAILROAD PRODUCTS, NEWS & EVENTS

• INDEX

• TABLE OF CONTENTS

Manuals. The series provides modelers and researchers with a quick go-to reference to identify major prototypes. This spiral bound volume covers Pacific Fruit Express, Santa Fe Refrigerator Despatch, American Refrigerator Transit, Fruit Growers consortium (FGEX/WFEX/BREX), Union Refrigerator including GARX, North Western Refrigerator Line, Northern Pacific, Western Refrigerator, Mather and others. It contains hundreds of photos along with captions, text, and tables. For additional information including ordering details visit speedwitchmedia.com.

RP CYC Publishing Company plans to release *Railway Prototype Cyclopedia Volume 34*, this month. This is a special expanded 193-page volume that provides updates, corrections, and additional photographs for RPC volumes 1 through 33. A total of 480 previously unpublished color and black and white photographs and diagrams that enhance earlier volumes have been assembled for this issue. For additional information including ordering instructions visit rpcycpub.com/v34flyer.pdf.

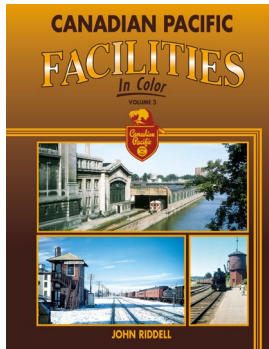
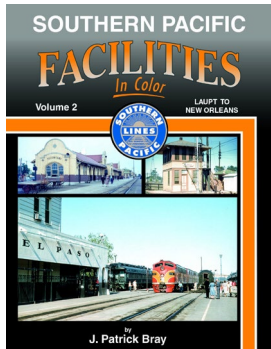

New hardcover books from **Morning Sun** include *Southern Pacific Facilities in Color, Volume 2 - LAUPT to New Orleans*, by J. Patrick Bray. Also *Canadian Pacific Facilities in*

Color, Volume 3, in which author John Riddell covers passenger stations, towers, and yards on the vast system – mostly during the period when CP equipment was wearing the distinguished maroon and grey livery.

Morning Sun has issued *Baltimore & Ohio Color Guide to Freight and Passenger Equipment* as a digital reprint. The postwar freight, passenger, and non-revenue rolling stock of America's first trunk line railroad is examined in more than 250 color images. The B&O operated a diverse and colorful roster thoroughly documented by rail historian Craig Bossler in this book first published in 1996. For information on all Morning Sun publications contact a dealer or visit morningsunbooks.com.

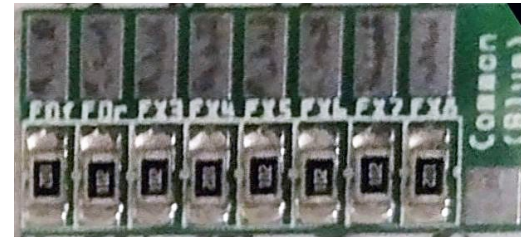

Nate's Light Iron Hobbies has introduced a DCC LED Resistor board, containing eight separate 1K Ohm 1/8 watt resistors on a single 3/4 x 11/32-

inch board. Designed to be installed on the common (blue) wire from the decoder, the board collects all of the positive leads from the LEDs into one place, simplifying wiring. The negative lead from the LED is connected to the DCC decoder in the normal manner. More information can be found at nateslightironhobbies.com/store/dcc-led-resistor-board.htm.



Redutex is selling a variety of adhesive-backed 3D textures suitable for creating model railroad scenery in various scales. Although new to North America, Redutex has been active in the

European market for several years. For additional information including ordering instructions visit redutex.com.

O SCALE PRODUCT NEWS

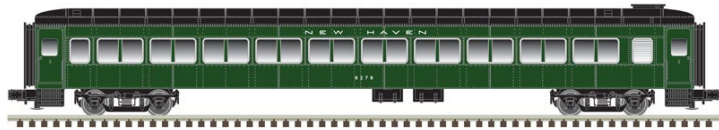

Atlas O has scheduled a late summer release for a new Trainman series of Osgood Bradley passenger cars. The O scale models feature rubber diaphragms, detailed interior with seating, interior lighting, functional doors and separately applied metal grab irons. Road names will be Boston & Maine, Kansas City Southern, Long Island Railroad, Southern Pacific, and New Haven. Unlettered cars will be available painted dark green with a black roof.



A General American 53-foot 6-inch express reefer is also scheduled for release by Atlas O during the third quarter. The prototype wood-sheathed cars were painted dark green

like the heavyweight passenger equipment they usually operated with. Road names will be Railway Express Agency, Denver & Rio Grande Western, Canadian National, Great Northern, Northern Pacific, and Pacific Fruit Express. Features include sprung die-cast GSC Commonwealth express trucks, metal ladders, stirrup steps and grab irons, and movable doors and roof hatches. All Atlas O rolling stock is available with a choice of 2-rail or 3-rail trucks. For additional information visit atlaso.com.

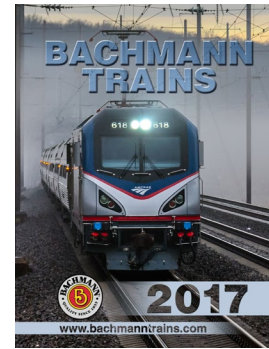

The latest combined catalog of **Bachmann** and **Williams by Bachmann** products is now available. The 344 page 2017 edition features items in all scales. Visit bachmanntrains.com to order a copy or to download a free pdf version.



Bachmann has released an On30 scale 2-6-0 locomotive decorated for Pennsylvania Railroad. It is also available for Denver & Rio Grande Western in

the colorful bumble bee scheme. Painted but unlettered models in both schemes are also available. Features of the Spectrum DCC-equipped Mogul include operating headlight, hidden drive train with metal gears, detailed pilot, sprung center axle for improved electrical pickup and tracking, and a short-coupled tender with coal load. The DCC equipped model is ready for the addition of a 16-bit SoundTraxx Tsunami plug-and-play sound module available for sale as a separate item. For additional information on all Bachmann products contact a dealer or visit bachmanntrains.com.



Rusty Rail is selling four stacks of old O scale tires. They can be placed against a

building or out in a field. The tires are unpainted resin castings. For more information visit rustyrail.com.

HO SCALE PRODUCT NEWS

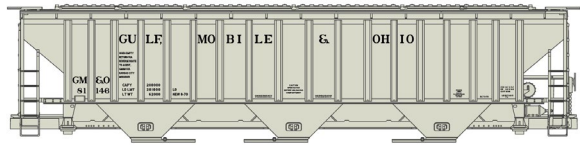

New HO scale kits available from **Accurail** include this Gulf, Mobile & Ohio

PS-3 triple-bay covered hopper. All Accurail kits include appropriate trucks and Accumate knuckle couplers.

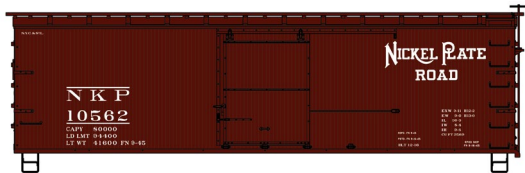

Accurail's new 36-foot double-sheathed wood boxcar is available decorated for Nickel Plate Road in the road's vintage style font. The HO scale model has steel ends and a steel fish belly underframe.

The kit for this 50-ton twin-bay hopper car with offset sides is based on a Great Northern car built in 1934.



Completing Accurail's releases for this month is an HO scale kit for a

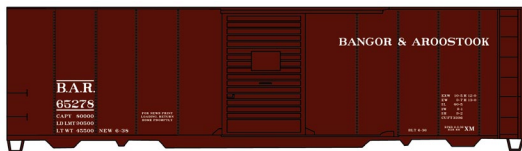

Bangor & Aroostook 40-foot AAR riveted steel boxcar with Youngstown sliding doors. The lettering indicates the car was new in 1938. For additional information on all Accurail products contact a dealer or visit accurail.com.

Bangor & Aroostook 40-foot AAR riveted steel boxcar with Youngstown sliding doors. The lettering indicates the car was new in 1938. For additional information on all Accurail products contact a dealer or visit accurail.com.

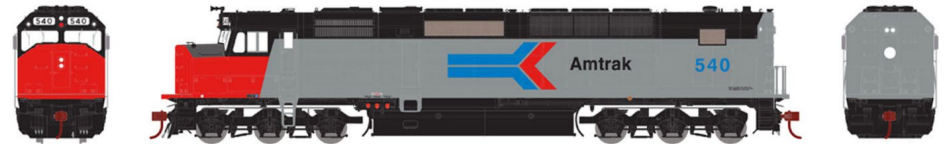

Athearn is showing the Amtrak and Santa Fe artwork for its Genesis series EMD SDP40F diesels. Each version will feature several road-specific details.



This early photo of the new tooling shows detail of the notched nose on Athearn's forthcoming SDP40F.



Both the Amtrak and Santa Fe yellow bonnet locomotives are scheduled for release this July.

A new production run of EMD SD70 diesels is scheduled to be released next January. The Genesis series HO scale model will be available decorated for BNSF, Canadian National, CSX (ex-EMDX Lease), Norfolk Southern (ex-NYS&W), and Union Pacific. The locomotive will be available for DC operation without sound and with Tsunami2 DCC Sound decoder.

APRIL NEWS | 8

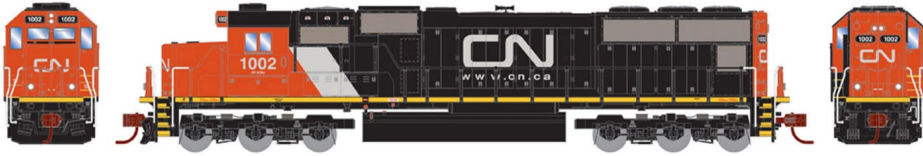

Athearn has scheduled the next release of its Genesis series GP7/9 for January 2018. Road names will be Burlington Northern (ex-SP&S), Maine Central, Norfolk & Western (in both blue and tuscan paint schemes), and Pennsylvania Railroad with Athearn's newly tooled train phone antenna. The HO scale models will be available for DC operation without sound, and with a Tsunami2 DCC Sound decoder.



Also due next January is a 50-foot Sieco boxcar decorated in Athearn's Primed for Grime paint with faded base colors to replicate in-service prototypes. The Genesis series model will be available decorated for Toledo, Peoria & Western; Atlantic & Western Railway, Chattahoochee Industrial Railroad, Canadian Pacific, Pickens Railroad, Raritan River, and Sabine River & Northern.

Ready-to-Roll models scheduled for release next January include a Trinity triple-bay covered hopper decorated for Archer Daniels Midland, Burlington Northern Santa Fe, CSX, Ferromex, Illinois Central, and Kansas City Southern. Also due in January are Gunderson Maxi III 5-unit well-cars in Primed for Grime paint. Road names will be Burlington Northern Santa Fe, CSX, Southern Pacific, Trailer Train, and TTX.

APRIL NEWS | 9



Athearn has included a new run of Yard Tractors in its January schedule. The models feature window glazing, molded cab interior, and rubber tires. Road names will be Burlington Northern, Canadian National, Conrail, Santa Fe, Union Pacific, and Canadian Pacific. The CPR tractor shown here is from a previous release.



Roundhouse brand products coming from Athearn next January include a wide-vision steel caboose decorated for the short-lived Southern Pacific Santa Fe Railroad that existed only briefly and only on paper. Additional road names include Union Pacific, Chessie System, MKT, and Santa Fe in the Kodachrome scheme. For additional information on all Athearn products contact a dealer or visit athearn.com.



Atlas has announced new numbers and road names for its Trainman series GP39-2 Phase 1 locomotives. Both Silver series DC and Gold series DCC units with ESU sound will be in the fourth quarter release. Road names will be Reading, Delaware & Hudson, Union Pacific, Wisconsin & Southern, and CSX YN3 scheme. The Trainman series features the same drive as Atlas's Master Series models. The decorated body shell has locating dimples for grab iron installation by the modeler.

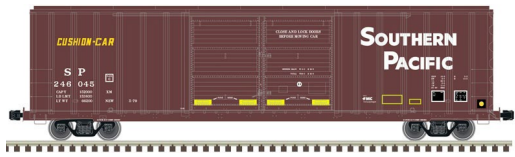

Atlas plans to release a brand new 52-foot boxcar with double doors during the third quarter of this year. The HO scale

model is based on a Plate C 5503 prototype with an X-panel roof as originally built by FMC for Southern Pacific. In addition to SP, other road names in this initial release will be Longview, Portland & Northern; and Amador Central. Three numbers will be available for each road. For additional information on all Atlas products visit atlasrr.com.



Banta Model Works is selling Everest Country Grocery, an HO scale craftsman-style kit. The kit has a laser-cut

plywood core overlaid with laser-cut clapboard and strip-wood. Signs, assembly instructions, and painting suggestions are included. The completed structure has a footprint of 4.4 x 5 inches. This is an economy version of a more extensive kit Banta offered several years ago. For additional information visit bantamodelworks.com.



Bowser Trains is booking reservations for a new production run of 100-ton hopper cars. The ready-to-run HO scale models

will feature detailed slope sheets and interior braces, roller bearing trucks with 36-inch metal wheelsets, and knuckle couplers. Delivery is planned for December. Road names will be New York, Susquehanna & Western; Detroit & Mackinac (both red and white schemes), Lycoming Valley, Pittsburgh & Lake Erie, Reading & Northern, Reading (speed lettering), Rock Island, Southern Pacific, and Wisconsin Central (ex-LEFC). The Chicago & North Western version will be available as shown here in green as well as with a black body. For additional information contact a dealer or visit bowser-trains.com.



Broadway Limited expects delivery next month on HO scale versions of the distinctive Chesapeake & Ohio Hudson Class L-1 4-6-4 steam locomotive. The imported ready-to-run model will be released in four road num-

bers in the original 1947 orange livery as well as the same road numbers in the later yellow boiler scheme. The models will be equipped with Paragon3 that features Rolling Thunder sound and operation in both DC and DCC environments. The factory is sold out on this initial release however some dealers may have limited supplies available. More info at broadway-limited.com.



Fos Scale Models will conduct two all-day workshops on April 8 and 9 at the Fos Studio in Stonington, CT. Saturday's session will focus on building wood structures. Sunday will be devoted to exploring realistic modeling techniques. For additional information

visit fosscalemodels.com/t/workshops or contact Doug Fos at fosscalemodels@gmail.com.



Fos's latest craftsman-style kit for experienced hobbyists is Lamont Photo & Film. The structure represents a small, somewhat seedy, camera shop. Of note is the unique roof-top sign with a laser-cut camera and letters. The kit also includes laser-cut clapboard walls, sidewalk, roof cards, plastic win-

dows and doors, laser-cut layered storefront, vintage color signs, and detail parts of both metal and plastic. The finished structure has a footprint of 4 x 6.5-inches. For additional information on all Fos products visit fosscalemodels.com.

.....

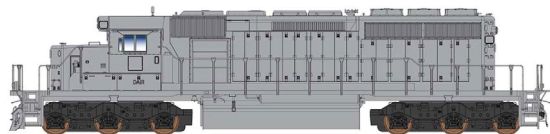

InterMountain Railway plans to include undecorated HO scale kits in its late

summer release of SD40-2 diesel locomotives. Both DC and DCC equipped versions will be available. The kits will include a number of separate parts to allow the hobbyist to create different version of the locomotive. A U.S. version (Item 43997[S]) will include appropriate skirts and steps as well as the long hood with dual headlights. A Canadian version (Item 43998[S]) of the kit will include additional Canadian-style parts. For details including road names on ready-to-run versions of InterMountain's SD40-2 see our report in the March 2017 edition of MRH. for more info, see Intermountain-Railway.com.

.....



Kadee plans to release a PS-2 twin-bay covered hopper decorated for Chicago & North Western in June. All Kadee HO scale ready-to-run models are equipped with Kadee couplers and two-piece self centering trucks.

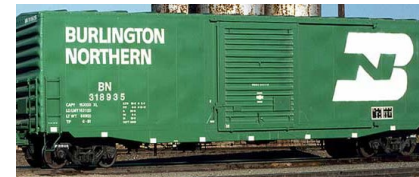

A July release date has been set by Kadee for an HO scale version of this 50-foot Burlington Northern PS-1 boxcar with a 10-foot sliding door. The prototype was built in 1966 and shopped in the summer of 1981.



Also due from Kadee in July is an Alton Railroad 50-ton AAR standard twin-bay open hopper car with offset sides. The prototype was built in 1945. Kadee will offer the HO scale ready-to-run model in two different road numbers. For additional information on all Kadee products contact a dealer or visit kadee.com.

.....

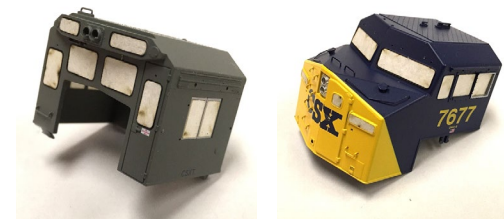

American Model Builders has added windows for Atlas HO scale Dash 8-40C diesels to its large selection of laser-cut windows for locomotives and other rolling stock. The new windows are available for standard cab (left) and wide cab (right) versions of Atlas' Dash8-40C. Both sets feature crystal clear, distortion-free laser-cut acrylic replacement window sets. Each kit includes all the cab window glass as well as the numberboard glazing for

both hood ends. The windows are pre-masked so they can be installed before the final finish is applied to the cab body. For additional information visit laserkit.com.



Monster Model Works has released a craftsman kit based on the historic Whitley & Whitley Building in Placerville, CO. The structure was built in 1920 to serve the Rio Grande Southern Railroad and mining operations in the San Juan Mountains. The town became known as Placerville after the RGS constructed a

depot and several passing sidings west of the original settlement. Historical information and working drawings for developing the kit were provided by narrow gauge experts Steve Harris, Michael Blazek and Jake Johnson.

The kit has 3D laser-engraved block stone siding, corners and coping; laser-cut doors, windows and glazing; and metal roofing material. A sign, assembly instructions, and weathering tips complete the kit. The assembled model is 3.5-inches high and has a footprint of 4.5 x 6.75 inches. For additional information visit monstermodelworks.com.



Summit USA has introduced a kit for a Pizza Hut Restaurant. The kit includes all building parts and window frames milled in white and black styrene and laser-cut in white acrylic. Clear acrylic window glazing, a street sign, self-adhesive logo signs,

and illustrated step-by-step assembly instructions are included. Painting suggestions are provided. The assembled structure is 2.75-inches tall and has a footprint of 9 x 6.125 inches. For additional information contact a dealer or visit summit-customcuts.com.

and illustrated step-by-step assembly instructions are included. Painting suggestions are provided. The assembled structure is 2.75-inches tall and has a footprint of 9 x 6.125 inches. For additional information contact a dealer or visit summit-customcuts.com.



Work continues at **Rapido Trains** on the development of an HO scale General Electric Dash 8-40CM. The spotting features of the prototype, also known as

the C40-8M, are the four-window North American cab, the cowl-style body and the “Draper Taper” cutout behind the cab to provide better visibility to the rear on full-width cowl units.



The HO scale model is Rapido’s first release in its budget-priced Prime Movers series. Features will include working ditch lights, metal grab irons, and a decoder (decoder plug on DC models) easily accessible in the fuel tank.



Dash 8-40CM locomotives were delivered to Canadian National, British Columbia Railway and Quebec North Shore & Labrador

between 1990 and 1994. Rapido will offer all six original decorating schemes. For additional information on Rapido products contact a dealer or visit rapidotrains.com.

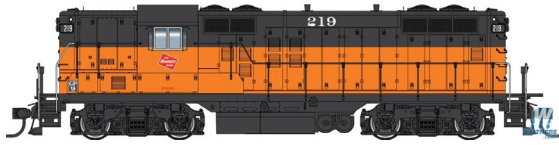

Walthers plans to release a new production run of its EMD GP9 in April 2018. Based on Phase 1 prototypes, the Proto series model features retooled hood contours. The HO scale model will be available for standard DC operation or with LokSound Select DCC and Sound. Road names will be Milwaukee Road, Bangor & Aroostook, Burlington Northern, Grand Trunk Western, and Southern Pacific.



Also coming from Walthers early next year is a Proto series 55-foot Trinity modified 30,145 gallon tank car. The model is based on a prototype updated with reinforced ends, revised end platforms, and multi-valve housing to comply with FRA mandates. Features include see-through etched-metal walkways and end platforms. Road names will be CBTX-Cit Group, PPRX-Conco Phillips, DPRX-PBL Holdin, SCMX-Shell Oil, and TILX-Trinity Leasing (white body). For information on all Walthers products contact a dealer or visit walthers.com.

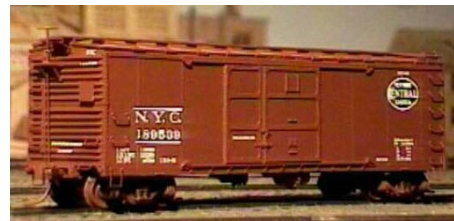

Westerfield Models has released an HO scale resin kit of a USRA steel automobile car. The model is based on a group of 4,000 cars built by AC&F and Standard Steel in 1922-23 for New York Central and its Michigan Central subsidiary. To accommodate loading and unloading automobiles the cars were equipped with one and a half doors. The craftsman-style kit

features a one-piece cast urethane body. Appropriate trucks and couplers are available for sale as separate items. For complete details visit westerfieldmodels.com.



Here is a preview of a kit for a class O-16-B ACL boxcar under development by **Yarmouth Model Works**. The sides and ends for the master were developed using Solidworks software tooling and then printed on a high resolution 3D printer. The final HO scale kit will include laser-cut running boards, photo-etched ladders, rungs and other detail parts, special decals from Black Cat Publishing, and Tahoe Model Works trucks. A firm date has not been established but a mid-summer release is targeted. More information at yarmouthmodelworks.com.

N SCALE PRODUCT NEWS

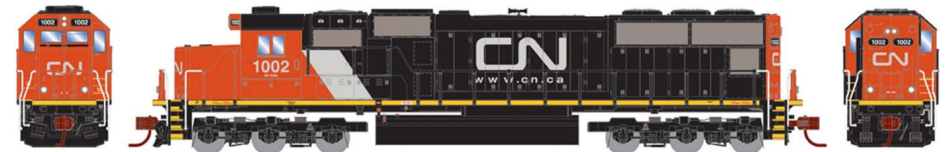

Athearn plans to deliver a new production run of EMD SD70 diesels next January. The N scale model will feature Athearn's new Spartan cab. Road names will be Canadian National, BNSF, CSX (ex-EMDX Lease), Norfolk Southern (ex-NYS&W), and Union Pacific. The locomotive will be available for standard DC operation with DCC-ready capability.

Also due from Athearn next January is a 50-foot Sieco boxcar decorated in Athearn's Primed for Grime paint with faded base colors to replicate in-service prototypes. The N scale model will be available for Toledo, Peoria & Western; Atlantic & Western Railway, Chattahoochee Industrial Railroad, Canadian Pacific, Pickens Railroad, Raritan River, and Sabine River & Northern. For additional information on all Athearn products contact a dealer or visit athearn.com.

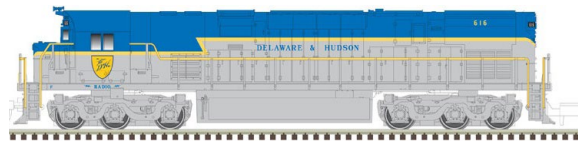

Atlas has scheduled the release its N scale Alco Century series 628/630 diesel locomotive with optional sound during the third quarter of 2017. A Gold series model with DCC sound and decoder will be available. A DC Silver series model will come with a speaker to ease conversion to DCC sound. In addition to the Delaware & Hudson scheme shown, the C-628 will be available decorated for NdeM (Ferrocarriles Nacionales de Mexico), and Southern Pacific.



The most distinctive spotting feature of the C-630 is the large after-cooler radiator housing which extends above the roofline and a modified cab that provided more interior space for the crew. C-630s will be available for Duluth, Missabe & Iron Range; Canadian Pacific, L&N Family Lines, Minnesota Commercial Railway, Western New York & Pennsylvania, and Union Pacific.

Additional new N scale models coming from Atlas during the third quarter include Master series 40-foot PS-1 boxcars with two



New York Central.

types of 6-foot sliding doors. Models with 5-panel Superior doors include Minneapolis, Northfield & Southern; Susquehanna, and

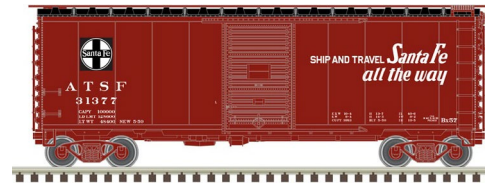

Rock Island, and Santa Fe.

Roadnames for models with Youngstown doors will be Nashville, Chattanooga & St. Louis; Richmond, Fredericksburg & Potomac;



New Atlas Trainman series models coming late this summer include a 3560 cu. ft. triple-bay Center-Flow covered hopper. The N scale model is based on an ACF prototype with five roof hatches, V-shaped end frames, and welded side sheet seams. Road names will be CSX, Delaware & Hudson, Illinois Central, Norfolk Southern, Southern Railway, Canpotex, and Potash.

New Atlas Trainman series models coming late this summer include a 3560 cu. ft. triple-bay Center-Flow covered hopper. The N scale model is based on an ACF prototype with five roof hatches,



Completing Atlas' list of new N scale releases planned for the third quarter is a Trainman series steel caboose. In addition to the New York Central Pacemaker scheme shown here, roadnames will be Canadian Pacific, Great Northern, Indiana Harbor Belt, Missouri-Kansas-Texas, and Santa Fe. An undecorated model will also be available.

Completing Atlas' list of new N scale releases planned for the third quarter is a Trainman series steel caboose. In addition to the New York Central Pacemaker



Atlas will soon offer the N scale trucks with metal wheelsets originally developed by BLMA. Both 70-ton and 100-ton versions of modern roller bearing trucks will be offered. A 70-ton truck

with solid bearings will also be available. For additional information on all Atlas products visit atlasrr.com.

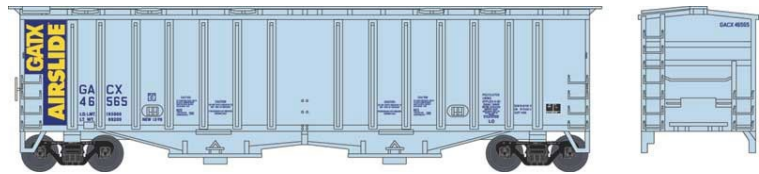

Bowser Train's next production run of N scale Airslide hopper cars is scheduled for release in December. The models will come with roller bearing trucks with Fox Valley Models metal wheelsets and body mounted knuckle couplers. Road names will be GATX, Archer Daniels Midland, BNSF Buffer Car, Brach's Candy, Burlington Northern, Chessie System C&O, Denver & Rio Grande Western, Milwaukee Road, M-K-T, Santa Fe, and Union Pacific. For additional details on all Bowser products contact a dealer or visit bowser-trains.com.

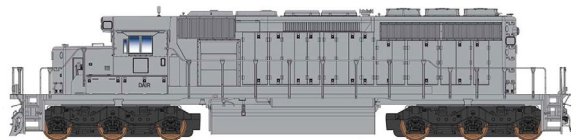

InterMountain Railway will include undecorated kits in its SD40-2 diesel locomotives due late this summer. Both DC and DCC equipped versions will be available. The N scale kits will include a number of separate parts to allow the hobbyist to create different version of the locomotive. A US version (Item 63997[D][S]) will include appropriate

skirts and steps as well as the long hood with dual headlights. A Canadian version (Item 63998[D][S]) of the kit will include additional Canadian-style parts. For details including road names on ready-to-run versions of InterMountain's SD40-2 see our report in the March 2017 edition of MRH. More information at intermountain-railway.com.

skirts and steps as well as the long hood with dual headlights. A Canadian version (Item 63998[D][S]) of the kit will include additional Canadian-style parts. For details including road names on ready-to-run versions of InterMountain's SD40-2 see our report in the March 2017 edition of MRH. More information at intermountain-railway.com.



KatoUSA has released the BNSF Swoosh version of General Electric's ES44AC GEVO diesel units. Road numbers 5751 and 5785

should be at dealers by the time you read this. Locomotives decorated for Canadian National and CSX are scheduled to be released this summer.



Eight-car sets of Bethgon Coalporters decorated for Norfolk Southern have been released by Kato to its authorized dealers.

BNSF Coalporters are scheduled for release later this month.

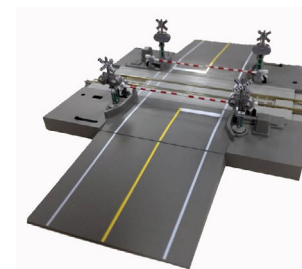

Kato plans to introduce this new N scale automatic highway crossing gate in May. The automated gate features multiple selectable warning sounds, blinking LED lights, and smooth actuating gate arms. An enclosed automated control system detects trains and lowers and raises the

gates. The system is DCC friendly and can be expanded for up to four tracks. For additional information on KatoUSA products contact a dealer or visit katousa.com.



Micro-Trains Line has released several new ready-to-run N scale models including this BNSF 70-foot Husky-Stack well-car. Built in 1992, the prototype car was designed to handle containers up to 48 feet in length in the bottom well.



Fifty-foot Airslide covered hopper cars with twin discharge bays decorated for Union Pacific are now available from Micro-Trains. Like the prototype, the N scale model rides on 100-ton Barber roller bearing trucks.



This N scale 40-foot boxcar is decorated for the 1947 Friendship Train. The car symbolizes the post-war project that collected food all across the U.S. for shipment to France and Italy. Over 250 cars of food and clothing were collected.

Micro-Trains has decorated this 70-foot heavyweight baggage car as a special Union Pacific car to transport thoroughbreds to and from horse races. The car is equipped with six-wheel passenger trucks. Horse cars typically accommodated up to 24



horses in separate stalls with feed and water troughs. For additional information on Micro-Trains Line

products contact a dealer or visit micro-trains.com.

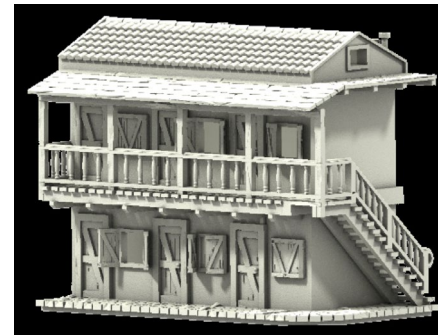

Old West Scenery offers more than 40 N scale 3D laser-printed structures and scenery items. Shown here is La Posada from the Pueblo Mexicana collection. All of the structures are fully assembled ready for paint. For additional information visit oldwestscenery.com.

NEW DECALS, SIGNS AND FINISHING PRODUCTS



Highball Graphics has released two new decal lettering sets for VIA Rail in

both HO and N scale. The sets will letter the first two pieces of equipment painted for Canada's 150th Anniversary. Both sets will require the modeler to mask and paint the large VIA on the side. For more information visit highballgraphics.com.

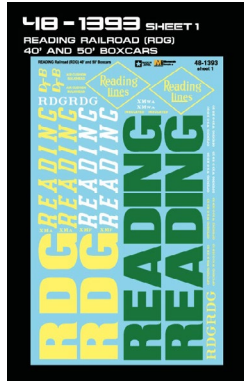
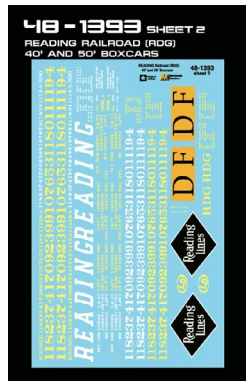

Microscale has released an O scale decal lettering set for Reading Railroad 40 and 50-foot boxcars.



Also new is an O scale decal set for Railbox RBOX and ABOX boxcars circa 1975-1984. Each set contains two sheets of lettering material. For additional information contact a dealer or visit microscale.com.

MinuteMan Scale Models, has an updated Scalecoat color chart available for download. To access the free chart visit minutemanscalemodels.com/v/vspfiles/Colorchart/ScalecoatColorChart.pdf.

Speedwitch Media has released several new HO scale decal sets including Baltimore & Ohio P-11 flat cars, and New York Central System (NYC, P&LE) 50-foot boxcars built 1939-1946. Also available are four new lettering sets for the Pennsylvania Railroad including FM flat cars and DD1-A containers, X29B

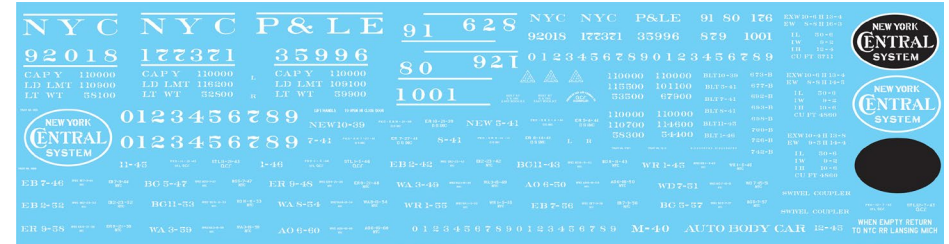

rebuilt boxcars, X26C rebuilt boxcars, and G22 gondolas and HB1/HB1A containers. Additional new decals sets are for Wabash panel-side hopper cars, Pacific Fruit Express R-40-14 refrigerator cars, Richfield AC&F 10,000 gallon Type 25 insulated tank cars, West India Fruit (ex-Erie) rebuilt boxcars, and Rohm & Haas pressed steel tank cars. To order visit speedwitchmedia.com.



Underground Railway Press sells a selection of vintage signs and advertisements under the brand name Quick-Signs. The material is suitable for applying to buildings and billboard structures. URP continues to expand its extensive collection of scale plans that includes drawings by Al Armitage, Nathan H. Allen, Peter Barney, Gordon Cannon, Edward H. Cass, Dan Abbott, John T. Derr, Ken Pruitt, Russ Simpson, Richard M Wagner, Thomas A. Yorke, and many others. For a current catalog send \$2.00 to Underground Railway Press, P.O. Box 814FP, Brevard, NC 28712-0814. More information at greatdecals.com/URPSigns.html.

i SEND US YOUR PRODUCT ANNOUNCEMENTS

If you are a hobby manufacturer with a product announcement, just [click here](#) and submit your announcement to us. Our web site and free magazine reach continues to grow, so get on board this new media train! ■

.....

DISCLAIMER

The opinions expressed in this column are those of the writer and do not necessarily reflect the opinion of *Model Railroad Hobbyist* or its sponsors. Every effort is made to provide our readers with accurate and responsible news and information, however, neither *Model Railroad Hobbyist* or the writer of this column can be held responsible for any inaccuracies or typographical errors that may inadvertently appear in this column.

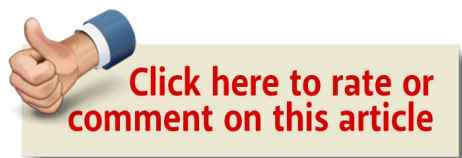

! BRIEFLY NOTED AT PRESS TIME ...

MRH has learned that **InterMountain Railway** is developing an N scale EMD SD38-2 locomotive. If all goes well the all-new model will be ready for release next spring. Meanwhile, Trinity 5161 cu. ft. triple-bay covered hopper cars scheduled for release this fall will be available in ten different BNSF Heritage schemes. For additional information including road names on the new models mentioned here visit intermountain-railway.com ...

Rail Graphics, the Illinois-based producer of custom decals, has announced plans to cease operations at the end of this year. Rail Graphics founder Ron Roberts told MRH he is currently in negotiations with a possible buyer.

Established in 1979, the company has become a major supplier of custom decals to model railroaders as well as an OEM source for numerous hobby suppliers including Custom Traxx, Great Decals, ICG Decals aka Daniel Kohlberg, Westerfield, Bethlehem Car Works, and several railroad historical societies. In announcing the closure, Rail Graphics said orders for new decals would not be accepted after December 1, 2017. For additional information visit railgraphicsdecals.com ...

Rapido Trains is interviewing for a repair and parts technician to work out of its Markham, Ontario office. Although training will be provided, experience in model train repair would be an important asset. Interested individuals are invited to submit a resume and cover letter to Rapido owner Jason Shrone at jshron@rapidotrains.com ...

ScaleTrains has released dry overseas containers decorated for Hub Group and COFC Logistics. The new containers are

BRIEFLY NOTED AT PRESS TIME *CONTINUED ...*

in the firm's Operator Series of HO scale models. Also new are HO scale Evans 510 RBL Kit Classics boxcars decorated for TP&W, UP, SP, N&W, L&N, IT, IC, BNSF, FEC, GTW, MP/ARMH, and RPCX-Ralston Purina, Georgia Pacific, and Armstrong. For more information visit scaletrains.com ...

Tichy Train Group has added 16 new images to its recently introduced line of HO scale roadside billboards (see MRH News March 2017). The new billboards are from the 1930s and portray a variety of familiar consumer products ...

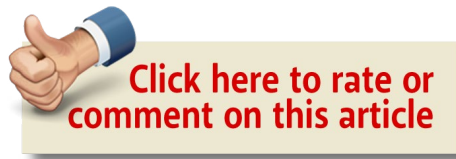

Want to help keep MRH free?
Then *click on ads!*

The MRH Media family

**Model Railroad
Hobbyist magazine™**

mrhmag.com

store.mrhmag.com



trainmasters.tv



More helpful insights and advice!

MRH Model Railroad Hobbyist magazine™ mrhmag.com Magazine Advertisers Goodies News/Events Authors Help Staff only

Model Railroad Hobbyist **Dream** TRACKWORK ROLLING STOCK LOCOMOTIVES New book series ... [Learn more](#)

Home / Recent posts

Recent posts

All recent posts My recent posts

Type	Post	Author	Replies	Last updated
Topic	Soldering question <i>new</i>	DSteckler	2 2 new	1 min 16 sec ago
Blog	The Breitenbach - Rosenheim Railroad Version II	michaelrose55	885 7 new	3 min 2 sec ago
Blog	Resin Casting with Two Part Molds	Benny	34 8 new	12 min 38 sec ago
Topic	Pacific Northwest RPM Date 2017	ctown2gn19	5 3 new	16 min 36 sec ago
Blog	Hawaii Island Railroad	umauma railway	175 24 new	20 min 9 sec ago
Topic	Buffering Speed Unwatchable	DWC	11 1 new	26 min 44 sec ago
Topic	You get what you pay for	GregW66	3 2 new	27 min 9 sec ago

[Get current issue](#)
[Recent posts](#)
[Recent posts by type](#)
[Make a web post](#)
[Blogs](#)
[Discussion forums](#)
[Community](#)
[My account](#)
[Contact us](#)
[Log out](#)
[Recent blog posts](#)



SELECTED EVENTS

April 2017

(Please note that many events charge a fee. Check individual info website for details.)

AUSTRALIA, VICTORIA, GEELONG, April 14-16, 13th Annual Australian Narrow Gauge Convention. Info at austnarrowgaugeconvention.com.

CANADA, ALBERTA, CALGARY, April 22-23, Supertrain 2017 - Model Train Show at Genesis Centre, 7555 Falconridge Blvd NE. info at supertrain.ca.

CANADA, ONTARIO, April 8-9, Lindsay & District 43rd Annual Model Train Show at the Victoria Park Armory. For more information send inquiry to waynelamb@sympatico.ca.

CALIFORNIA, BAKERSFIELD, April 19-23, NMRA Pacific Coast Region Daylight Express Convention, at Double Tree by Hilton, 3100 Camino Del Rio Court. Info at pcnrmra.org.

CALIFORNIA, OCEANSIDE, April 22, Model Train Swap Meet, sponsored by North County Model Railroad Society, at Oceanside Heritage Park, 220-230 Peyri Drive. Request info from Rich Blankinship at 760-518-0014 or email info@ncmrs.org.

COLORADO, COLORADO SPRINGS, April 29-30, TECO - Train Expo Colorado, at Mortgage Solutions Financial Expo Center, 3660 N. Nevada Avenue. Info at tecoshow.org.

INDIANA, ELWOOD, April 29, 10th Annual Hoosier On30 Meet (All NG and fine scale modelers invited), at Wesleyan Church, 2535 E. Main Street. Request info from Kevin Jones at krjone01@aye.net. Info at facebook.com/events/583155998540932.

MASSACHUSETTS, WELLESLEY HILLS, April 22, NMRA HUB Division Spring TRAINing Show, at Wellesley community Center, 219 Washington Street. Info at hubdiv.org.

MICHIGAN, MUSKEGON, April 23, Muskegon Railroad Historical Society Spring Model Train and Hobby Show, at USS LST 393 Veterans Museum Ship, 560 Mart Street. Info at facebook.com/muskegonrail.

MICHIGAN, WYOMING, (Grand Rapids area), April 8, Spring Train Show sponsored by Grand River Valley Railroad Club, at HSB Home School Building, 2625 Burlingame Avenue SW. Info at grandrivervalleyrrc.org.

MISSOURI, ST. LOUIS, April 6-8, 32nd Annual Sn3 Symposium, at St. Louis Airport Marriott, 10700 Pear Tree Lane. Info 2017sn3symposium.com.

NEW YORK, GARDINER, April 21-22, Mid-Hudson On30 Meet. Info at midatlanticng.org.

PENNSYLVANIA, PITTSBURGH, April 29, Model Railroad Jamboree, sponsored by NMRA Mid-Central Region, at Sewall Center, Robert Morris University, Moon Campus. Info at keystonedivision.org.

WASHINGTON, MONROE, April 29, Pacific Northwest Prototype Modelers Meet, at Evergreen State Fairgrounds. Info at northwestrpm.com.

May 2017, by location

CANADA, BRITISH COLUMBIA, VANCOUVER, May 5-7, Railway Modellers Meet, at Simon Fraser University Burnaby Campus, West Mall Centre. Info at railwaymodellermeeetofbc.ca.

CANADA, ONTARIO, KITCHENER, May 5-7, NMRA Niagara Frontier Region Convention, at Conestoga College, Doon Campus, 299 Doon Valley Drive. Info at GrandRiverExpress.ca.

CALIFORNIA, SANTA CLARA, May 25-27, 27th Annual O Scale West, at Hyatt Regency Santa Clara, 5101 Great America Parkway. Info at oscalewest.com.

IOWA, AMES, May 18-21, NMRA Thousand Lakes Region/Mid-Continent Region Joint Convention, at Quality Inn, 2601 East 13th Street. Info at mcor-nmra.org/Conventions/index.php.

PENNSYLVANIA, ALLENTOWN, May 18-20, 23rd National Model Trolley Meet, sponsored by East Penn Traction Club, at Allentown Fairground Agri-Plex Charles Hall, 17th and Chew Street. Info at eastpenn.org.

PENNSYLVANIA, KIMBERTON, May 19-20, 34th Annual Module Meet, sponsored by Mid-Atlantic Narrow Gauge Guild, at Kimberton Fire Company Fairgrounds. Info at midatlantieng.org.

VIRGINIA, FISHERSVILLE, May 7, 31st Annual Shenandoah Valley Model Train & Railroading Show, at Augusta Expo, 277 Expo Road, sponsored by Augusta County Model Railroad Club. Info at acmrrc.org.

Future 2017, by location

CALIFORNIA, FREMONT, June 10-12, 6th annual open house at Tri-City Society of Model Engineers, Niles Plaza Depot & Freight Building, 37592 Niles Blvd. Info at nilesdepot.org/niles/modelrailroads.html.

CALIFORNIA, RICHMOND, June 17, Bay Area Prototype Modelers Meet, at St. David's School Hall, 871 Sonoma Street. Info at bayareaprototypemodelers.org.

COLORADO, DENVER, August 30-September 2, National Narrow Gauge Convention, at Marriott Denver Tech Center Hotel. Info at 37nngc.com.

CONNECTICUT, ENFIELD, June 2-3, Northeast Proto Meet, at Holiday Inn Springfield South. Info at nerpm.org/index.html.

FLORIDA, ORLANDO, July 30-Aug 5, NMRA National Convention. Info at nmra2017.org.

FLORIDA, ORLANDO, August 4-6, National Train Show, at Orange County Convention Center. Info at nationaltrainshow.org.

ILLINOIS, COLLINSVILLE (St Louis area), June 23-24, St. Louis Prototype Modelers Meet, hosted by Lonnie Bathurst and John Golden, at Gateway Convention Center. Details at icg.home.mindspring.com/rpm/stlrpm.htm.

NEBRASKA, DESHLER, July 1-2, Train Show & Open House at Spring Creek Trains, at 4th and Race Street. Info at springcreek-modeltrains.com.

OKLAHOMA, TULSA, June 21-25, Annual Convention of the Santa Fe Railway Historical & Modeling Society. Info at sfrhms.org/conventions.

2018 and beyond, by location

MISSOURI, KANSAS CITY, August 5-12, 2018, NMRA National Convention. Info at kc2018.org.

UTAH, SALT LAKE CITY, July 7-13, 2019, NMRA National Convention. Info at nmra2019slc.org. ■

Clickable advertiser index – 1

[Accu-Lites](#)
[American Ltd \(San Juan\)](#)
[ANE Models](#)
[Archer Fine Transfers](#)
[Athearn](#)
[Atlas Model Railroad Co.](#)
[Bachmann](#)
[Bachus](#)
[Backdrop Junction](#)
[Banta Modelworks](#)
[Berrett Hill Trains](#)
[Black Cat Publishing](#)
[Blair Line](#)
[Bowser](#)
[Canyon Creek Scenics](#)
[Clever Models](#)
[Coastmans Scenic Products](#)
[Coffman Graphics](#)
[Crow River Products](#)
[Digitrax \(2 page spread\)](#)
[ESU LokSound](#)
[Fast Tracks](#)
[Fox Valley Models](#)
[Good Deals DCC](#)
[Great Decals](#)
[HO Diesel Supply](#)
[Iowa Scaled Engineering](#)
[ITLA Scale Models](#)
[Ken Patterson.com](#)
[Lights 4 Models](#)
[Litchfield Station](#)
[Logic Rail Technologies](#)

[Main Street Heritage Models](#)
[Model Railroad Benchwork \(1\)](#)
[Model Railroad Benchwork \(2\)](#)
[Monster Modelworks](#)
[Motrak Models](#)
[Model Railroad Control Systems](#)
[Mountain Subdivision Hobbies](#)
[MRH Store \(1\)](#)
[MRH Store \(2\)](#)
[MRH Store \(3 - 2 page spread\)](#)
[MRH Store \(4\)](#)
[MRH Store \(5\)](#)
[Mt Albert Scale Lumber](#)
[National Train Show](#)
[NCE \(2 page spread\)](#)
[Nick & Nora Design](#)
[Norfolk & Western Hist. Society](#)
[North American Railcar Co.](#)
[Oak Hill MRR Track Supply](#)
[Pre-Size Model Specialities](#)
[Precision Design Co.](#)
[Rapido \(1\)](#)
[Rapido \(2\)](#)
[Ring Engineering \(1\)](#)
[Ring Engineering \(2\)](#)
[Rulers-of-the-World](#)
[Rusty Stumps](#)
[Scale Trains](#)
[Scotty Mason Show](#)
[Sea Port Model Works](#)
[Select Model Railroads](#)
[Streamlined Backshop Services](#)

Clickable advertiser index – 2

[Soundtraxx \(Blackstone\)](#)
[Southern Digital](#)
[TAM Industries](#)
[TAM Valley Depot](#)
[Tony's Train Exchange](#)
[Train Control Systems](#)
[TrainMasters TV \(1\)](#)
[TrainMasters TV \(2\)](#)

[TrainMasters TV \(3\)](#)
[TrainMasters TV \(4\)](#)
[Traintek](#)
[TSG Multimedia](#)
[Walthers](#)
[Westerfield Models](#)
[Yankee Dabbler](#)
[Yarmouth Model Works](#)

Clickable "other" index

[Other – Contents](#)
[Other – Cover](#)
[Other – Derailments](#)
[Other – Hobby Marketplace](#)
[Other – MRH Sponsors](#)
[Other – Yes it's a model](#)

DOWNLOAD ISSUE





REVERSE RUNNING

commentary

DON HANLEY



[Click here for reader comments](#)

DON'T NEED NO STINKING STAGING AS THE HOBBY HAS DEVELOPED, OLDER LAYOUT



design methods have fallen into disfavor. It used to be loading the layout with track in various loops with bridges crossing over/under each other and having the trains run through the scene multiple times was considered ideal.

Today, layout design best practice is a more linear approach with

the trains running through each scene only once – and the modern layout design connects to the outside world via staging yards.

While connecting our layout to the outside world via staging is intriguing, let's reconsider the use of staging yards. First, consider the costs: yards are expensive. Turnouts aren't cheap, and add to that powering the turnouts, the wiring and controls required to operate a yard and it all adds up to *expensive*.

▶ **STEPPING OUTSIDE THE BOX WITH A CONTRARY VIEW**

To have a proper staging yard you need lots of space, which is a precious commodity. So where do many staging yards end up? Under the layout with minimal clearance.

What happens when you have a derailment in this staging yard, or need to repair a turnout? Have you ever attempted to re-rail cars with only 4"-6" of verticle clearance for your 1:1 hand? Easier said than done.

Yards are often a bottleneck on a layout, so why are we adding more? Consider the following "typical" conversation:

Crew caller: Dispatch, time for the 20th Century Limited, where is it?

Dispatch: It's still in Chicago staging.

Crew caller: Let's get it going, I have a crew ready to run it!

Dispatch: It's on staging track 12 behind local x2953.

Crew caller: Let's move that train out of the way!

Dispatch: Can't. Have two inbound trains waiting to get into staging!

...and so it goes!

Why hide all of our beautiful locomotives and nicely detailed cars in hidden staging? They should be proudly displayed on the visible layout. Spaghetti layout designs were not that bad.

Just think of the advantages of spaghetti layout design:

- The elimination of costs associated with staging yards
- No need to re-rail cars in hidden staging with minimal clearance
- No maintenance on turnouts buried in a hidden staging yard
- All your beautiful rolling stock and motive power will be on the *visible layout!*

Prototype ops on a linear layout design with staging is way over-rated. Let's get back to running our trains in circles – it's high time to repopularize roundy-roundy and get rid of staging forever!



DERAILMENTS



Building a CP Railway steam loco in 1928

Vintage footage showing the construction of Canadian Pacific Locomotive #3101 from beginning to end. At 3685 hp, these engines were known as some of the largest and most powerful non-articulated locomotives of their day.

Loco #3101 achieved 25 years of service before she was retired to IPSCO Park in Regina, Saskatchewan. ■

► BIZARRE FACTS AND HUMOR (SUPPOSEDLY)

OFF THE RAILS ...

Q: Why can't the loco engineer be electrocuted?

A: Because he's not a conductor!

Q: Why can't a steam locomotive sit down?

A: Because it has a tender behind.

Q: If an electric train is heading north, which way would the steam be coming out?

A: There wouldn't be any steam! It's an *electric* train. ■

.....

\$ GET PAID ...

If you're the first to submit a bit of good humor or bizarre facts and we use it, it's worth \$25! Just send to derailments@mrhmag.com ■

.....

Coming next issue ...

- Jerry Fassnacht's Pennsy and Reading, on tour at this summer's NMRA Convention in Orlando
- One Module Challenge First Place layout design
- Modeling a Vermont scene
- Build a soldering iron timer
- And lots, *lots* more!

 **Click here to rate or comment on this article**

