

HAVING FUN WITH TRAINS

DECEMBER 2017 | FREE

MRH

MODEL RAILROAD HOBBYIST



*Happy
Holidays!*

George Sellios' Franklin & South Manchester update

» **READ NOW**

ALSO:

- More layout overhaul rebuilding
 - Modular plan of Duluth, MN docks
 - PC boards for model railroaders
 - Tips for modeling concrete streets
 - Loco headlight modeling ideas
- ... and lots more inside!*

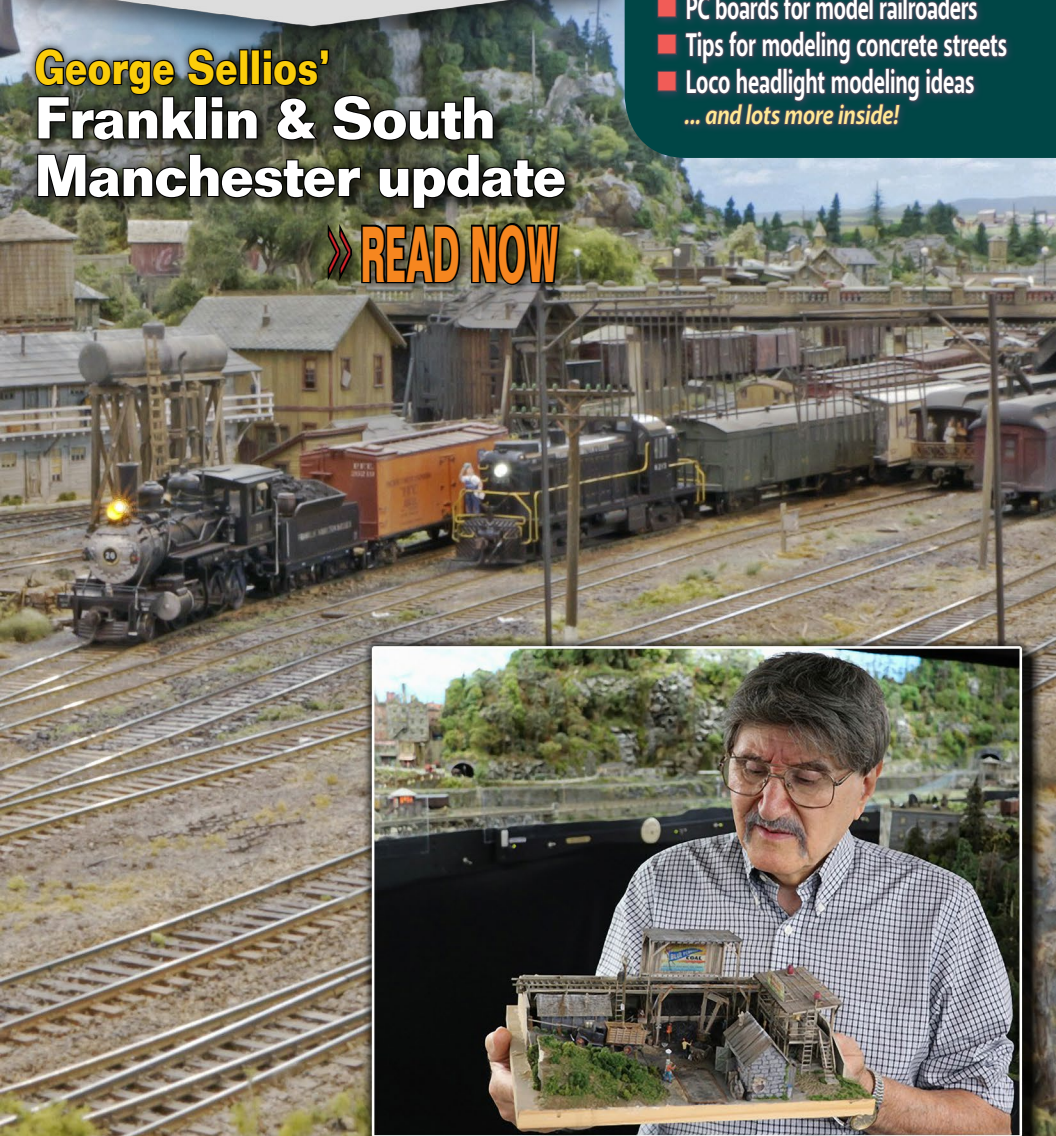

STANDARD EDITION | PORTRAIT



DOWNLOAD



SUBSCRIBE
(free)

AVAILABLE FOR PRE-ORDER IN DECEMBER 2017 FROM



ATLAS MASTER® N & HO MP15DC LOCOMOTIVES



KANSAS CITY SOUTHERN



CONRAIL



MORRISTOWN & ERIE



UNION PACIFIC



GMTX



READING AND NORTHERN

CLICK HERE!



CIT

FOR MORE INFORMATION OR TO LOCATE A DEALER, PLEASE VISIT WWW.ATLASRR.COM.
ATLAS MODEL RAILROAD CO., INC. • 378 Florence Ave., Hillside, NJ 07205



STAFF CREDITS

(Updated 11/26/17)

Front cover: George Sellios' trusted assistant Thom Driggers gives us a tour of the updates George has made recently to his Franklin & South Manchester.



ISSN 2152-7423

Editorial Staff

Joe D. Fugate, Publisher and Editor
Don Hanley, Assistant Editor

Production

Patty Fugate, Pasteup and Layout
Joe Brugger, Copy Editing
Mike Dodd, Copy Editing

Technical Assistant

Jeff Shultz

Advertising

Les Halmos, Account Manager
Daniel Nava, Advertising Assistant
Jean-François Delisle, Marketing Assistant

News and Events

Richard Bale, News and events
Jeff Shultz, News and events

Columnists

Les Halmos, Modular railroading
Larry Smith, Narrow Gauge/Shortlines
Bruce Petrarca, DCC
Ken Patterson, Reporter at large

Rotating Columnists

Jack Burgess, Getting Real column
Nick Muff, Getting Real column
Mike Rose, Getting Real column
Tony Thompson, Getting Real column

Rob Clark, Imagineering
Dave Meek, Imagineering
Ray Dunakin, Imagineering

Issue password: Dec2017

Published for the glory of God. [What's this?](#)



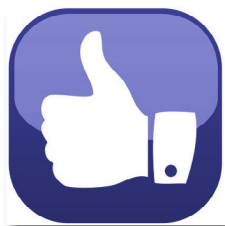

MRH SPONSORS

A - E



acculites.com



americanlimitedmodels.com



railroadhobbyshow.com



archertransfers.com



athearn.com



www.atlasrr.com



bachmanntrains.com



bachrus.com



backdropjunction.com

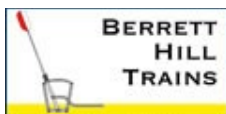

berretthill.com/trains



blairline.com



bowser-trains.com



mycaboose.com



coffmaneng.com



con-cor.com



www.digitrax.com



trackplanning.com



esu.eu/en

[Vendors: Get your clickable logo here ...](#)

MRH SPONSORS | 2

F - R



handlaidtrack.com



iascaled.com



kadee.com



lights4models.com



litchfieldstation.com



micro-trains.com



store.mrhmag.com



modeltechstudios.com



mtalbert.com



ncedcc.com



www.pwrs.ca/main.php



rapidotrains.com



ringengineering.com



rustystumps.com

[Vendors: Get your clickable logo here ...](#)

• [INDEX](#)



[SUBSCRIBE](#)
(free)

• [TABLE OF CONTENTS](#)

MRH SPONSORS | 3

S - Z



sanjuancarco.com



scaletrains.com



soundtraxx.com



sodigi.com



sbs4dcc.com

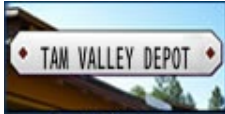

tamvalleydepot.com



tsdcc.com



trainfest.com



tonystrains.com



traintekllc.com



tsgmultimedia.com



walters.com



yankeedabbler.com

[Vendors: Get your clickable logo here ...](#)

Looking for something? Check the MRH Marketplace!

The screenshot shows the MRH Marketplace website with several vendor listings:

- Model Railroad Hobbyist | December 2017 | #95**
- MRH MARKETPLACE | 2**
- CROW RIVER PRODUCTS**: New 1/2" HO BB B Locomotive Engines, 2017 Model Catalog.
- TAM Industries**: Precision Scale Model Kits, 1/2" HO Scale.
- 17 Pocket Couplers**: 17 Pocket Couplers, 1/2" HO Scale.
- 1/2" HO Scale**: 1/2" HO Scale Locomotives, Engines, Cars, Trucks, Buses, Trailers, and more.
- Where the Rail Awaits the Sea**: 1/2" HO Scale Model Kits, 1/2" HO Scale.
- CHRYSLER WITH 6 WHEEL UPG**: HO - D - N Scale.
- USA DS Express Box**: NWP Railroad Empire.
- 1/2" HO Scale Models**: 1/2" HO Scale Models, 1/2" HO Scale.
- Affordable track planning**: Affordable track planning, 1/2" HO Scale.

Take me there!

On30
SCALE

Norman Rockwell
Creator of the Norman Rockwell Train Series



NEW

Click to learn more.

NORMAN ROCKWELL'S AMERICAN CHRISTMAS
ELECTRICALLY OPERATED • ITEM NO. 25023 • MSRP \$399.00
SHIPPING NOW!

BATTERY-OPERATED AND ELECTRIC!
NEW ON30 SETS FOR HOLIDAY FUN

Bachmann has two new ready-to-run On30 sets that are sure to delight both the beginner and the experienced hobbyist on your holiday gift list. A festive tribute to one of our most beloved national artists, *Norman Rockwell's American Christmas* train set displays four classic Rockwell holiday illustrations. It includes a 2-6-0 steam locomotive with operating headlight and coal tender, lighted combine, lighted observation car, 56" x 38" oval of snap-fit nickel silver E-Z Track®, magnetically operated E-Z Mate® couplers on all cars, power pack and speed controller, and illustrated instruction manual. Our auto-reversing, battery-operated *Norman Rockwell's Main Street Christmas* features a Streetcar with a Norman Rockwell illustration, Norman Rockwell passenger image, headlights, and lighted interior. Its 10 pieces of auto-reversing E-Z Track® and battery operation make set-up quick and easy on a table, shelf, or mantelpiece (4 AA batteries required for operation; batteries not included). With a choice of these great sets, you'll want to hop aboard now for holiday fun with Bachmann!

AUTO-REVERSING



NEW

Click to learn more.

NORMAN ROCKWELL'S MAIN STREET CHRISTMAS STREETCAR SET
BATTERY OPERATED • Item No. 25100
MSRP \$275.00 • SHIPPING NOW!

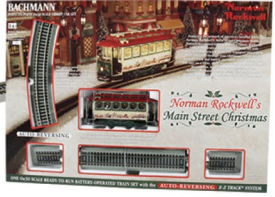

Also available

The *Jingle Bell Express* rushes last-minute wishes from the North Pole to homes around the world. Decked out in red and green and carrying a sweet cargo of holiday treats, the HO scale *Jingle Bell Express* will deliver merry dreams around your Christmas tree for years to come. This ready-to-run train set includes 0-6-0 steam locomotive with operating headlight and coal tender, single-dome tank car, box car, quad hopper, off-center caboose, 47" x 38" oval of E-Z Track®, power pack and speed control, and illustrated instruction manual.

HO
SCALE



Click to watch video.

JINGLE BELL EXPRESS
Item No. 00724
MSRP \$245.00 • SHIPPING NOW!



Bachmann Industries, Inc. • 1400 East Erie Avenue • Philadelphia, PA 19124 USA • www.bachmanntrains.com

Click for more information.

• INDEX



SUBSCRIBE
(free)

• TABLE OF CONTENTS



TABLE OF CONTENTS

FEATURES

What's new on the FS&M

THOM DRIGGERS

See what George Sellios has been up to lately



One Module Challenge honorable mention

JIM MOE

Plan for a modular layout depicting Duluth, MN docks



PC boards for model railroaders

MARK UNDERWOOD

Learn to make your own printed circuit boards easily

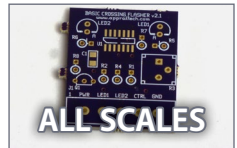

Craft paints for weathering

BILL KENNEDY

Replace Floquil's weathering colors with economical paint



Cornerstone concrete street tips

DIRK P. REYNOLDS

Using Walther's street system even without instructions



ALSO: MRH Marketplace | Subscriber extras

TABLE OF CONTENTS | 2

COLUMNS

MRH Q-A-T: Loco headlight, reporting marks, ...

compiled by JOE BRUGGER

DCC Impulses: Not quite a chainsaw layout

BRUCE PETRARCA

Getting Real: Modeling Skinner's Eddy: 2

MIKE ROSE

What's Neat: Digitrax WiFi, UP Turbines, ...

KEN PATTERSON

Photo feature: Yes, it's a model - Merry Christmas!

compiled by DON HANLEY

First Look: ScaleTrains.com Tier IV GEVO

JEFF SHULTZ

Derailments: Bizarre facts & humor

compiled by the MRH STAFF

NEWS and EDITORIAL

Asst Editor: How deep into model railroading are you?

DON HANLEY

News & Events: December 2017

RICHARD BALE & JEFF SHULTZ

Reverse Running: Time for dead rail to die?

JOE FUGATE



ADVERTISEMENT

FIRST TIME IN HO SCALE*

GE C39-8

(Actual Model Shown)



ALSO AVAILABLE IN NORFOLK SOUTHERN



Preorder Now 



*First time in mass-produced plastic

© 2017 ScaleTrains.com, Inc. ScaleTrains.com, Rivet Counter, and respective logos are trademarks of ScaleTrains.com, Inc.
 ScaleTrains.com, Inc. 7598 Highway 411 Benton, TN 37307
 844-9TRAINS 844-987-2467 International 423-299-3689

WWW.SCALETRAINS.COM
 Scene and photography by Ken J Johnson
 Preproduction model shown



• INDEX

• TABLE OF CONTENTS



Model Railroad Hobbyist | December 2017 | #94

ASSISTANT EDITOR

editorial

DON HANLEY
.....



[Click here to rate or comment on this article](#)

HOW DEEP INTO MODEL RAILROADING ARE YOU?

IT'S DECEMBER AND CHRISTMAS IS FAST UPON US.

This is the season many of us got our start in model railroading with that train set under the Christmas tree.

But you're far past that now, right? Let's go deeper ... ask yourself, "Am I growing in the hobby?" Your first reaction might be to say "of course," but hold on, not so fast.

Let's dig deeper.

At MRH we think of the hobby as having three levels, with each one taking you deeper into the hobby:

Level 1. You buy locomotives and rolling stock with little pre-planning. You are a consumer. You may have a layout, but you have not ballasted the track yet, and are not convinced your track plan is right. You may hesitate when a guest asks to see your layout. You are uncertain of your modeling skills and abilities: you're not yet sure just what you can and can't do.

Level 2. Ballasting your track moves you on deeper to level two. You are now a modeler, not just a consumer. You may be on layout #2 or more – if

• [INDEX](#)
.....



[SUBSCRIBE](#)
(free)

• [TABLE OF CONTENTS](#)
.....

ASSISTANT EDITOR'S THOUGHTS | 2

so, you have taken lessons from the previous layouts. When guests ask to see your layout, you are fine showing it to them and running the trains. You've upgraded or replaced purchases from your level one days to serve your interests better now. You exercise your skills regularly and improve them. You are more confident: you're sure of what you can and can't do.

Level 3. You move still deeper to level three by embracing historical research, improved modeling realism, and more in-depth layout operations. Your layout operates reasonably well due to set standards for trackwork, locomotives, and rolling stock. You may host or participate in formal operating sessions, often with a fast clock. Good scenery and structures matter a lot. You are quite confident: you know precisely what you can do and you eagerly explore new techniques and materials. A level three modeler inarguably involves more dedication, but will deliver a level of satisfaction that will never be realized at level 1 or 2.

ADVERTISEMENT



Kadee
June Pre-Order



#4531 MNS 1157..... \$39.95

2018 Kadee® Patriotic Car



#6923 KDC 023 \$42.95



For More Pre-Order Cars Click Here

ADVERTISEMENT



CABOOSE™
Sharing Our Passion for Trains Since 1938

Click Here for the Serious Modeler's Resource!

More than 170,000 items, over 490 manufacturers, most at a discount from full retail – all at a fair price. **As always, in-stock orders of \$100.00 or more ship free within the Continental U.S.!***

*surcharges may apply for oversized items.

10800 West Alameda Ave.
Lakewood, CO 80226
(303) 777-6766

NORTHERN PACIFIC 10000-SERIES BOXCAR



4,000 built
Seen across
America



In use
1923 until
the '70s

[CLICK HERE](#)

• [INDEX](#)



[SUBSCRIBE](#)
(free)

• [TABLE OF CONTENTS](#)

BNSF Fuselage Transportation 2-Packs

3 Different 2-Packs Available

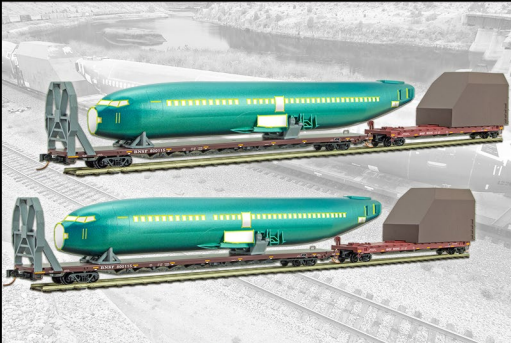

Coming January 2018

VISIT www.micro-trains.com FOR MORE INFORMATION

**MICRO-
TRAINS-
LINE**

N
SCALE 1:160

Checked us out lately?

- ✓ HO/N and now O scale products too!
- ✓ Laser-cut Structures & Bridges.
- ✓ Advertising & Storefront Signs.
- ✓ Highway Signs, vintage & modern.
- ✓ New Detail Items.
- ✓ Laser-cut Grade Crossings.
- ✓ Billboards, roadside & rooftop.
- ✓ Laser-cut Graffiti Decals
- ✓ 1000's of satisfied customers.

**WHAT'S
NEW?**
↙

Established 1993...

Blair Line

ASSISTANT EDITOR'S THOUGHTS | 3

Not to disparage the beginning levels: we all start there. Just like babies, we all need to crawl first, then walk. What you need to ask yourself is how long am I going to crawl, or am I going to move on to the deeper levels?

I believe more than a few modelers remain at level one for a couple of reasons.

First, there seems to be a stigma about adults playing with trains. Remember the train set that you received for Christmas and then outgrew?

Then there is pride. We may think we will be laughed at behind our back or thought less of in some way if we let others know about our hobby, or if we let fellow modelers know we are not as advanced as they might think we might be.



Diesels
EMD SD50



REFRESHED TO RUN



GREAT SOUND, SUPERIOR VALUE

THE NEW RTR EMD SD50 DIESELS FEATURE ECONAMI SOUND

In an effort to keep up with a changing marketplace, the fuel crisis of the late 1970s, and competition of that era, EMD responded with the SD50. Generating 3600 horsepower from a 16 cylinder 645F3 prime mover. The principle of fewer cylinders equating to fuel economy was a lesson learned with the GP39-2. EMD scaled this approach to the larger six-axle SD50. As several railroads jumped on board with the SD50, these workhorses can still be found rebuilt and running today. The Athearn Ready to Roll SD50 has been refreshed with factory installed sound, enhanced detail, while maintaining superior RTR value.

- Separately applied wire grab irons
- New rubber MU hoses
- Separately applied coupler cut levers
- Fine scale handrails molded in engineering plastic
- Etched metal windshield wipers
- Detailed fuel tank
- New looking HTC trucks Hyatt or Timken roller bearings (per prototype)
- With sound version features Econami Sound by Soundtraxx



VISIT ATHEARN.COM FOR COMPLETE LISTING
OF ROADNAMES AND PRICING

HORIZON
H O B B Y

VISIT

Your Local Retailer

CLICK

Athearn.com

CALL

1.800.338.4639

SERIOUS FUN™

©2007 Horizon Hobby, LLC. Athearn, Genesis and McHenry are registered trademarks of Horizon Hobby, LLC. All other trademarks, service marks and logos are property of their respective owners. Final models may vary slightly from photos shown. 5792

• INDEX



SUBSCRIBE
(free)

• TABLE OF CONTENTS

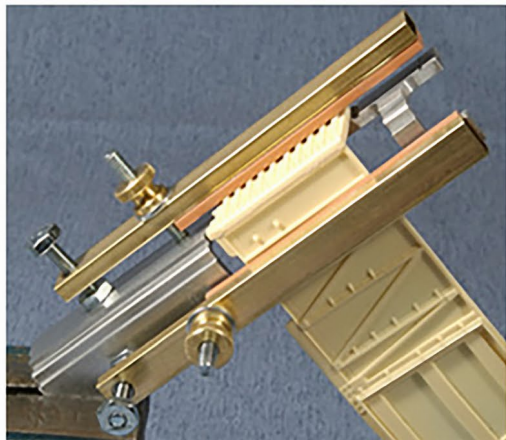
Combo Right Clamp™

Combo Right Clamp™
with cast resin boxcar

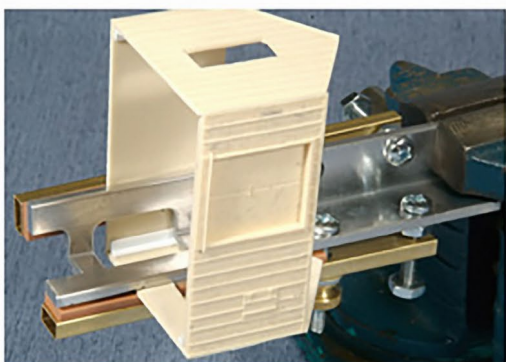

Combo Right Clamp™
with Wolf Design Pump House

**Click here for
all our products ...**

Tools for Modelers

Coffman Graphic Solutions Co.
1500 River Circle, Richmond,
KY 40475-7907

ASSIST EDITOR'S THOUGHTS | 4

This kind of thinking holds many at level one. Digging deeper to level two likely means moving out of your comfort zone. If you're willing to get uncomfortable for a little while, going deeper can be more rewarding, often with a deeper sense of satisfaction.

Level two modelers are the backbone of the hobby. They have refined their focus on what they model. As a modeler who has gone deeper to this level, you most likely have picked an era to model and are more focused on a limited number of prototype roads for your inspiration.

Refining your focus on what you model refines your purchases. You are no longer just a consumer, but you look for items that fit specific needs.

Moving deeper into this level means you also purchase more tools and supplies to build models.

Those further along in level two may write one or more articles for MRH or other magazines.

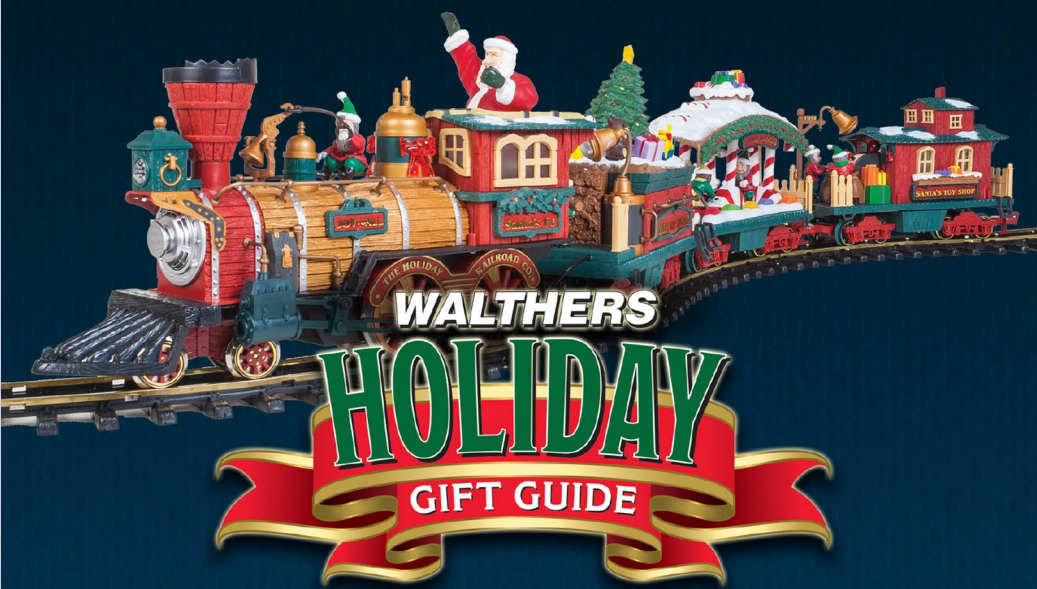

Find the perfect train gift in minutes

- Hundreds of items from complete starter sets to must-have modeling supplies
- Domestic orders received by Noon CST December 8, ship before Christmas – [click here for additional order deadlines](#)

Start your holiday shopping on the right track!



**Making holidays
magical.**

WALTHERS

Everything you need to build a great layout

• **INDEX**



SUBSCRIBE
(free)

• **TABLE OF CONTENTS**

How can you tell if you're a level one modeler or not? Here is a somewhat tongue-in-cheek analogy offered by TMTV Executive Producer Barry Silverthorn.

Railroad Modeler#1: If I have a country club membership, three sets of high-end golf clubs, monogrammed golf balls, all the gear, and I subscribe to Golf Digest – but have never actually swung a club, am I a golfer?

Railroad Modeler#2: No, you're just a spectator.

Railroad Modeler#3: I would say you're an *enthusiast*.

Railroad Modeler#2: Maybe if you have crappy 1960s era clubs that you bought at a garage sale but you build a golf course in your backyard, *then* you're probably a golfer.

Railroad Modeler#3: Just probably not one that any other self-respecting golfer would recognize, though.

It's also true the longer you stay at the shallow end as level one, the more likely you are to get bored with the hobby and eventually drop out.

So if you're level one, to go deeper:

1. Take time to evaluate what you really want. This includes:
 - Mak a list of prototype railroads that fascinate you.
 - Determine what era you like most. Maybe it's modern, or the steam to diesel transition era, or it might even be something earlier. Look at what you have purchased to date. You may find that you have subconsciously picked a favorite road and era.
 - Make an honest assessment of your skills.
2. Don't try to be a lone wolf. Get involved with other modelers. The MRH forum is a great way to start connecting with other modelers.
3. Consider using the TOMA concept that MRH promotes. This is a good way to to learn and improve your skills in bite-sized chunks.

THE LATEST FROM MT. ALBERT SCALE LUMBER...

MT. ALBERT LUMBER YARD



10" x 10" footprint as shown
\$125.00 free shipping

No. 11 in a Series of Limited Edition Craftsman Kits – HO Scale

Three Complete Structures 3D Printed Cut Off Saw
Sylvan 2 Ton Chevy Flat Bed Truck Kit
Stoney Creek Corrugated Aluminum and Tar Paper Roofing
Detail Parts from Faller, Grandt Line, & Tichy Train Group
Laser Cut Plywood, LaserBoard & Real Wood Shingles
Laser Cut Jigs for Pallets & Fencing
Step-by-Step Instructions DVD of Construction Photos

Mt. Albert Scale Models
320 St. Patrick St, Port Dover, ON, N0A 1N0 CANADA
service@fast-tracks.net www.handlaidtrack.com

ORDER YOURS TODAY FROM...

shop online 24/7

handlaidtrack.com



• INDEX



SUBSCRIBE
(free)

• TABLE OF CONTENTS

Bowser

HO & N Scale GLa 2 Bay Hopper Cars

Ready to Run

HO: Features: Crisp details and sharp painting and printing, metal wheels and knuckle couplers.

N Scale: Features: Crisp details and sharp painting and printing. Roller bearing trucks with metal wheels and body mounted knuckle couplers.

Road Names:

B&O, Blue Coal, BR&P, Cambria & Indiana, GB&W, LV, O&W, PM&Y, PRR MOW, PRR, & Waddell

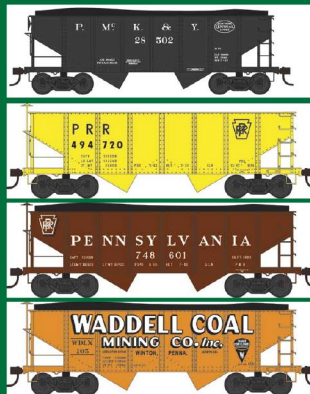
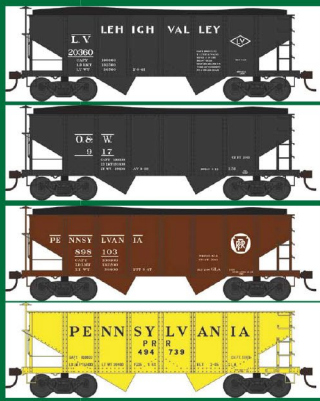

HO Freight Car Kits

KIT INCLUDES: One piece plastic molded body, under frame, brake wheel, air tank, brake cylinder, triple valve, free rolling trucks with metal wheels, knuckle spring couplers, smooth painting, sharp lettering & car weights.

In Stock!!

\$17.95 each



12 & 14 Panel & 70 Ton Covered Hoppers

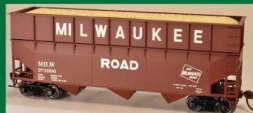

55 Ton Fishbelly & Wood Chip Hoppers



Click here to check out the details for these and other great Bowser Products

ASSISTANT EDITOR'S THOUGHTS | 6

For those of us who are level two or three modelers, we need to encourage the level one modelers to dive deeper into level two. This is good for the hobby and will help it grow, too.

We at MRH can look in the mirror too – the hobby press needs to present articles that help encourage level one and early level two modelers to dig deeper into the next levels.

Have a Merry Christmas everyone!



[Click here to rate or comment on this article](#)

ADVERTISEMENT

TCS *WOWSound*

**Version 4 of WOWDiesel
NOW SHIPPING!**

WOWDiesel Version 4 Introducing the
645 Non-Turbo Prime Mover

All with Unmatched CD Quality Sound at
TRUE 16 bit Resolution that nobody else can
come close to!

[click here](#)

[Learn why loco sound fans prefer WOWSound ...](#)

Remember you "Rivet Counters", Sound has rivets too and TCS counts them better than anyone!

www.TCSDCC.com

• [INDEX](#)



SUBSCRIBE
(free)

• [TABLE OF CONTENTS](#)

MRH “TOMA WITH A TWIST” CONTEST

ENTRY DEADLINE: January 31, 2018

Goal: Design the “starting position” for a sectional home layout design using TOMA.*

GRAND PRIZE: \$1000, plus get published as an MRH cover story

First Prize: \$750; Second Prize: \$500; Third Prize: \$350;
First, Second, and Third prize also get published.

Honorable mentions: \$100 each, publishing at editors’ discretion.

Hypothetical room is 14’ x 20’. Space under the stairs not available, and a 4’ clearance must be maintained along the utility wall.

Note: This is a sectional home layout design, no modular standard required.

Room 14’ x 20’

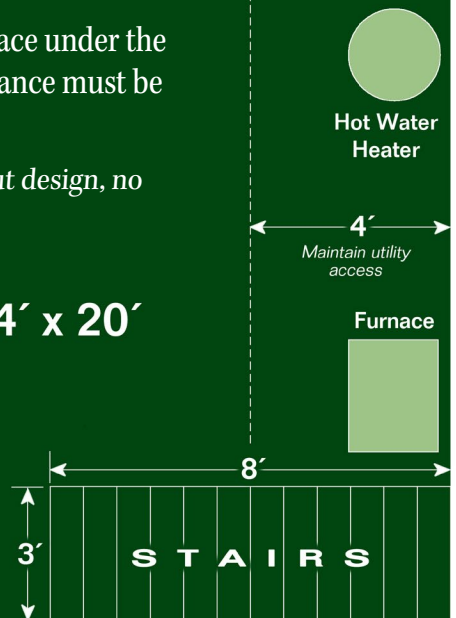

*For reference, see the July 2017 MRH Editorial, “TOMA with a twist”.

CONTEST RULES

- Modules can be any size or shape but must fit up the stairs and through the door at the top of the stairs (80" tall and 30" wide) without damage or pinching your fingers.
- Scale: From Z to O, using any track gauge.
- Design the "starting position" for layout construction phase 1 – we want to see one or two TOMA module sections that can be completely finished and configured for an operating session. Show and tell how staging would work. Tell a brief backstory of the line and how it operates.
- Your TOMA modules need to have some form of temporary staging, either singled-ended staging off one/both ends, or double ended staging connected to both ends of the modules, which would also allow continuous running if desired.
- Don't waste your time drawing and describing a detailed room-filling layout. Rough in outlines of the other modules, that is, the "ending position." Just sketch simple boxes and lines to show how the modules will fit in the room. Bonus points awarded for explaining – in words, sketches or both – a phased module construction progress plan.
- Modules can follow a standard or not. Custom sections okay.
- Module support method / height up to you, but please describe.
- Innovative or creative approaches get extra points: please describe and illustrate if possible.
- Include a cost estimate for the starting position. There is no need to actually build anything, this is a design contest only.
- This contest is *all about getting started*. People who can get that far will be able to fill in the rest with their own imagination.
- All submissions must be publishable. If the submission is not formatted to be ready for publication, it will be disqualified. Take the time to be complete, provide captions, and to describe things completely in your text. See the [MRH submission guidelines for more information](#).

SUBMIT ENTRY (Choose "Contest Entry")





LAST ISSUE'S RATINGS

The five top-rated articles in the [November 2017 issue](#) of *Model Railroad Hobbyist* are:

- 4.8 Getting Real: Modeling Skinner's Eddy
- 4.8 Low angle smartphone photography
- 4.7 What's Neat: Build a loco cradle, ...
- 4.6 St. Thomas on the Canada Southern
- 4.6 MRH Q-A-T: Wheel dots, consolidated stencils, ...

Issue overall: **4.9**

Please rate the articles! Click the reader comments button on each article and select the star rating you think each article deserves. Thanks! ■

*TrainMasters TV is part of
the MRH product family.*

*TMTV members not only get great network TV level
videos, they help pay for MRH and keep it free ...*

Get the first 50 issues of
**Model Railroad
Hobbyist magazine™**

Save
yourself
endless
hours of
downloading

On a data DVD for \$10!

Send me one!

(Sold by Model Trains Video)

*Includes a coupon
good for \$20 off on
TrainMasters TV*

*Over 5000
pages of
how-to
information
on model
railroading*



• **INDEX**



SUBSCRIBE
(free)

• **TABLE OF CONTENTS**



New Arrivals – Limited Run PWRS / River Point™ Vehicles!!!

Ford F-450 XLT Regular Cab Utility

Modern Era Hi-Rail & Highway Trucks

PWRS 



HO
SCALE



PACIFIC WESTERN RAIL SYSTEMS
SPECIAL RUN CAR

Canadian National (CN)
Canadian Pacific (CP)

Pacific Western Rail Systems

NORTH AMERICAN RAILCAR CORPORATION



Accuracy and
Detail... in Scale



National Steel Car 5092 cf Combo Door Box Car 1971 - present

CLICK HERE FOR
HO - 5092 Boxcar

CLICK HERE FOR
N - 5092 Boxcar



BCOL - light green, built 1972



BCOL - brown, CN noodle & url, vents, shopped 2003

Our 1st run of this exciting new model freight car will feature 9 different paint schemes, with 12 Rd #s for each.

Follow the links to see the unique features and variations to each road name and series, as our extensive research leads us to produce the many variations in car sides, side sills, ends, floor, roof, doors and door details... the list goes on...

It's time to add these superbly detailed cars to your roster so you can ship forest products on your railroad!

NARC Cars are sold
exclusively through

Pacific Western Rail Systems

• INDEX

• TABLE OF CONTENTS



MRH Q-A-T

column

compiled by
JOE BRUGGER



[Click here to rate or comment on this article](#)

QUESTIONS AND ANSWERS

Locomotive headlight

Q. I am looking to add a headlight to my brass 0-8-0 made in the 1960s by Tenshodo. Does anybody have good tutorials on how to do this, or recommendations for lights/LEDs to use? The light is mounted hanging out from the center of the smokebox face.

I am doing a two-phase DCC conversion starting with the headlamp and motor, and then installing a light on the tender with a speaker later.

—Sancho Murphy

A. Steve G.: With a typical brass casting headlight such as one from Cal-Scale, I guess you could use a Pico LED, which is a micro size. I tried them but they were too delicate – I ripped the wires off two and gave up. On my Mantua 2-8-2 and 4-6-2, I used 3mm white LEDs that were pre-wired for 12 volts with a resistor already

► MRH QUESTIONS, ANSWERS, AND TIPS





1. Chet Zaiko installed the headlight in this locomotive about 20 years ago. LEDs weren't common then. An MV lens that fit the headlight opening was drilled from the back to make it appear that there is a bulb in the light. An LED could also be used. Holes were drilled through the back of the headlight housing and the smoke box to feed the bulb leads through. *Chet Zaiko photo*

installed on the plus lead. They have 6-inch leads – positive red (right rail) and negative black (left rail).

3mm LEDs have a ridge or step around the back end. The entire LED, including the ridge, will fit in a 5/32-inch hole or ID tube. I used a 5.5mm length of K&S #8129 3/16-inch brass tube. Routing and hiding wires is a challenge. For DC, I build a special circuit including a bridge rectifier, capacitor, LED driver, and diode for my LEDs, since I use both headlight (always on) and tender light (reverse only). I do not know what circuit, if any, you would need for DCC.

MRH Q-A-T | 3

Paul Jacobsen: I just did a headlight for an HOn3 Shay. The Cal-Scale brass headlight was drilled and reamed enough to snake the 1.8mm LED leads through. I patched the back a bit, and used insulated magnet wire to make fishing through this boiler easier. The headlight casting was then filled with Loctite 402 glue, which dries clear.

Lutz: There are different color LEDs available:

- Pure white replicates neon tubes, searchlights and spotlights
- Sunny white looks more like a halogen lamp
- Golden sunny white, also called warm white, resembles a bright incandescent lamp
- Golden white looks like normal incandescent lamps, and
- Super golden white imitates the tone of older incandescent lamps and kerosene lamps

A great deal can be done with varying the value of series resistors. So you can vary the loco headlights from a dim 1860s kerosene burner up to today, when loco headlights may actually be a cluster of LEDs.

I drill the back of the headlight housing and the smokebox front with a 0.8mm (#46) drill bit. Carefully deburr the holes, and paint the reflector silver. My preference is a warm-white 0603 LED with soldered-on micro-strand wire. Put a drop of CA on the LED before inserting it into the housing and let it dry to get an insulation layer. Thread both wires through the bores and insert the LED, aligning it to face to the front. Use clear parts cement or another non-conductive clear glue to fix it in place. Solder a 1K or 1.2K ohm resistor in place, then make a cover glass out of clear styrene and glue it to the headlight front.



BandOShortline107: I prefer to use a surface-mount LED in the housing, attaching it with CA. This is followed by Aileen's Clear Tacky Glue as a lens. It will fill the housing and level itself. Once cured, it is clear and looks good to my eyes. I tint the light with translucent yellow paint. When drilling the housing, take your time; there is no rush and you should be fine.

Geoff Bunza: The easiest tints I have found to use are Tamiya clear acrylics. I use orange, yellow, and red most often. I purchase only white LEDs now, to lower my inventory numbers. You can also use permanent pen markers, and some use glass coloring tints made for stained glass work.

Read the whole headlight thread at mrhmag.com/node/30717.

Reporting marks

Q. Does the rolling stock in a train usually follow the locomotive's railroad line (i.e.: CSX loco with CSX box cars) or can there be a mix as in CSX loco with CSX, CN, Southern box cars? If so, would CSX have freight cars from rail lines out west, like BNSF or BN? I'm not referring to leased freight cars, which I know would be in the mix.

—Pauly

A. Nick: If you hire a box car (rail car) from any of the railroads, it can go anywhere in the system in North America to deliver its goods. If I understand your question correctly, you could observe a train with different railroads' locomotives on the head end followed by rail cars from any or all of the railroads, as well as non-railroad-owned cars.

Irish Rover: Freight cars wander everywhere, since a load can be sent from Boston to LA. Theoretically, once the B&M car gets unloaded in LA, it should



[Click here to rate or comment on this article](#)



Archer

FINE TRANSFERS
PROUDLY SERVING MODEL BUILDERS SINCE 1989

**THE ORIGINAL
SURFACE DETAILS™**

**WE NOW HAVE MORE
THAN 130 SHEETS OF
RIVETS, LOUVERS,
TREADPLATE, WELD
SEAMS AND MORE
CAST ONTO
MICROSCALE CLEAR
DECAL FILM**

LOW SHIPPING:

**DOMESTIC USA ORDERS
\$2.80
INTERNATIONAL ORDERS
\$9.95**

**CLICK HERE TO
VISIT OUR WEBSITE!**

"Archer Fine Transfers 3D decals have revolutionized kitbashing and scratchbuilding. Putting rivets or other low-relief details like louvers or weld seams on your models is now as easy as applying decals."

Joe Fugate
Publisher/Editor
Model Railroad
Hobbyist



Archer Fine Transfers • PO Box 1277 • Youngsville, NC 27596 • USA
(919) 570-1026 • info@archertransfers.com • archertransfers.com

Backdrop Junction

Your Stop for Railroad Backdrops

Click Here ➔

**For the Finest in Custom
Designed backdrop**



www.backdropjunction.com

SANTA FE TK-N & TK-O LATE 2018



American Limited

6 numbers per version! Please contact your dealer!
www.americanlimitedmodels.com

Do You DETAIL?
OUR SELECTION
WILL BLOW YOU
AWAY.....

OVER 1000 DESIGNS

WWW.MODELTECHSTUDIOS.COM
N HO S O SCALE

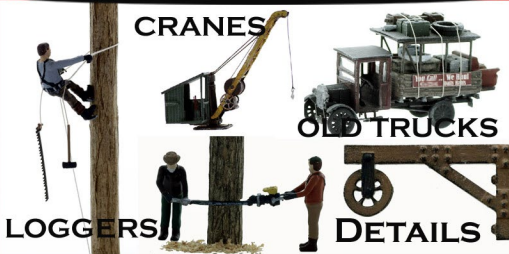

LOGGERS **CRANES** **OLD TRUCKS** **DETAILS**





2. Look for reporting marks in the lower left-hand corner of a passing freight car. UP 79103 is company-owned, and TLX 251782 is operated by a tank car leasing company. *Graham Line photo*

be working its way back to home rails, so that B&M car should be a relatively unusual sight on the west coast unless it was in some kind of dedicated service.

Some types of cars wander further than others, and some research into your time and place comes into play there. Since the Pennsylvania Railroad was huge in its time, you would see a lot more of their cars far away from home than you would see cars belonging to a short line.

David Husman: Since the post-Civil War period, the US railroads have relied on the “interchange” of equipment. Prior to that, when a shipment was made across country, the goods would be transferred between cars on the different railroads. Some of that was required because some railroads used different gauge tracks. After the Civil War, the majority of railroad lines were standard gauge



LED's, Signs, and Sounds for
All Scales

*Merry
Christmas*

& HAPPY NEW YEAR

find us on facebook.

www.lights4models.com

614-296-8691

Want it on Blu-ray?

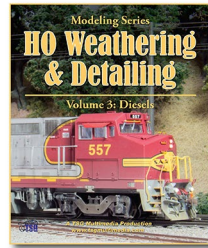

Selected titles are
now available on
Blu-ray disc in
spectacular HD!

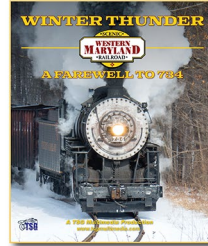
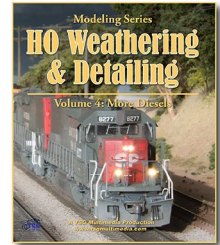

CLICK FOR
BLU-RAY



TSG Multimedia

and so shipments would stay in the cars they were loaded in and the railroads would exchange cars.

As a result, virtually any car from any standard gauge railroad could be found on any other railroad. Certain railroads with large car fleets tended to show up more often like PRR, NYC, B&O, and NP. Boxcars tended to travel more; hoppers tended to travel less.

For a steam-era railroad, a suggested mix has been 50% home road cars, 25% direct interchange cars and 25% other roads. For a modern era, it should probably something like 50% private-owner cars (reporting marks end in "X"), 25% home-road cars, 25% other. Obviously the mix depends on what part of the country you are modeling and what businesses/traffic you model.

Tony Thompson talks about modeling a freight car fleet at mrh-mag.com/magazine/mrh-2011-12-dec/getting_real.

• INDEX



SUBSCRIBE
(free)

• TABLE OF CONTENTS



Playback problems? [Click here ...](#)

3. Here's a nice YouTube video showing a Norfolk Southern train with a mixture of reporting marks. As the train speeds up, you may need to hit the pause button to read the reporting marks, but there is quite a mixture. *pwalpar video, submitted by gsinos*

Read more about how freight cars travel at mrhmag.com/node/31215.

TIPS

Hobby Lobby ops tray

I am using a wood tray bought at Hobby Lobby to help organize my On30 operating sessions. I place cars and car cards on it when I'm swapping-out rolling stock at the interchange/staging track when the session resets for another train.



[Click here to rate or comment on this article](#)

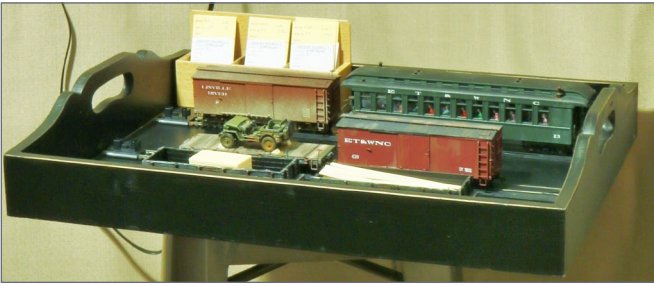

4. An inexpensive wooden tray organizes rolling stock and paperwork for quickly swapping out trains during operating sessions, and can be wired to allow programming DCC decoders. *Lee Bishop photo*

Some HO Atlas Code 100 reailer sections make it easy to load up rolling stock and it will hold more than enough cars for a single narrow gauge train. After mounting the track with machine screws, I added a car card box with a compartment for each track.

I also bought some wired alligator clip sets at a local auto parts store. They can be used to connect to the programming function on my DCC system and convert any of these tracks on the tray to a program track as needed.

During op sessions, I can have a new set of cars ready on this tray in another room, ready to go and reset the session almost right away. Before, I'd have to go under the layout to swap-out cars one at a time and make sure I grabbed the right car cards as well. And who's to say I can only have one tray?

—Lee Bishop

.....
\$ GET PAID FOR YOUR TIP

We pay \$25 per tip we publish, or \$40 each if the tip also includes a photo or finished drawing. [Click here and select article type TIP.](#) ■

.....



From first train set to railroad empire...

*Our complete line of DCC products
grows with you. Discover the fun!*

- Designed and manufactured in the U.S.A.
- Preferred for ease of use and ergonomic design
- Unlimited scalability for any size model railroad
- Plug-and-play means more time running trains
- Great customer service and excellent support



See your dealer



Visit our new and improved web site for all your DCC needs!

- Get the latest new product announcements
- Watch our detailed how-to videos
- Browse the all-new Information Station
- Enjoy secure online sales, day or night!

Visit **ncedcc.com**



• **INDEX**



SUBSCRIBE
(free)

• **TABLE OF CONTENTS**

Litchfield



STATION

**Litchfield Station
Carries A Full Line Of
Digitrax Products**

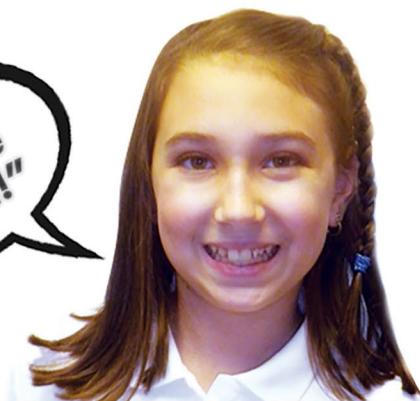

-CLICK HERE to visit our website-

www.LitchfieldStation.com

623-298-7355



DCC IMPULSES

column



Click here to rate or comment on this article

BRUCE PETRARCA MMR
.....

NOT QUITE A CHAINSAW

AS I HINTED IN LAST MONTH'S COLUMN, THINGS are topsy-turvy in my world just now. Linda and I have lived in the same subdivision (robson.com/communities/pebblecreek) for over 20 years. We were in our late 40s when we moved into this 55+ community on an age waiver. There was one floor plan that we liked when we first visited. We couldn't figure out what to do with the living room or formal dining room in that plan, but we loved the great room. So, we built a different model.

In the intervening years, we have seen various things that folks have done with our beloved floor plan. Earlier this year, a house just down the street from us with that floor plan was offered at a very attractive price. So, we purchased it.

What to do with the 15 x 15 foot living room? Wall it off and make it into my train room – much better than the 12 x 10 area [4] that I had just up the street. The dining room was also walled off and now is our office, with a nice east-facing bay window. I'm sitting there writing this column now.

▶ DCC TIPS, TRICKS, AND TECHNIQUES

• INDEX
.....



SUBSCRIBE
(free)

• TABLE OF CONTENTS
.....

DCC IMPULSES | 2

Fairly soon after the closing, I moved a lot of the Rocky Mountain Pacific (RMP) Fn3 garden railroad (mrddcu.com/layouts/RMP) to the new house [1 & 3]. I ripped up the track, packed the locos and cars, and moved them down the street on my two-wheel hand truck. They took up residence in the new garage [3].

We spent this summer overcoming 20 years of benign neglect in the “new” house and are just now getting moved in. One of our last moves was to remove the benchwork from the old train room [4 & 5], which was accomplished yesterday. Soon, we will have the “old” house ready to list for sale.

Planning new layouts

Once the “new” house was purchased, I began thinking of how I wanted to build my new garden layout and my new indoor one. In this column, I’ll walk you through my thoughts as I prepare for two new layouts.



1. The Rocky Mountain Pacific (RMP) railroad as shown at an October 2015 open house. Things weren’t done to the point of running trains back then, but I was able to have a static display for our round-robin garden club. *Bruce Petrarca photo*



The Future of Model Railroading

ESULLC 23 Howard Street Montoursville, PA (570) 980-1980

CabControl WIRELESS CONTROL SYSTEM

- ✓ Completely wireless model railroad operation
- ✓ Ergonomic, Android based remote control unit with TFT Display
- ✓ Internal database capable of holding more than 16,000 locomotives with specific names and symbols and up to 28 functions per locomotive.
- ✓ Easy to create multiple unit consists. Capable of configuring and controlling more than 1,000 switches and other accessories
- ✓ Conveniently updatable with internet connection
- ✓ Runs all DCC decoder equipped locomotives
- ✓ Automatic train detection using RailCom-Plus®
- ✓ Integrated 7A Booster

ESU Mobile Control II

- + Android operating system
- + 3.2" TFT Display, 800x400 resolution
- + Large Dial for easy speed control and direction change capabilities.
- + 4 user-personalized buttons
- + Micro USB port for Software Updates and battery charging
- + 5-8 hours of battery life.
- + 3.5 mm stereo headset port (microphone & headphone)

ESU Integrated Control Unit

- + CabControl creates a wireless network for over 32 wireless controllers
- + Connects through your LAN to provide internet connection
- + USB Port for Software Updates and throttle charging
- + DC 5.5 mm / 2.1 mm socket for external regulated DC power supply



Locomotives

Data for over 16000 locos can be held in the system
Loco Icons show the engine you are running
28 colorized graphical Icons for easy function identification



Accessories

More than 1000 accessories can be controlled and can have status visually displayed



Consisting

Easily created virtual consists so no CV changes are needed
Ability for all functions to be controlled while in consists



Conveniently Updatable

Updated easily for free as new features become available



Ethernet

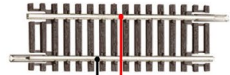

YouTube

[Click here for a short introductory video!](#)

• INDEX



SUBSCRIBE
(free)

• TABLE OF CONTENTS

DCC IMPULSES | 3

The first question was one of gauge and scale. The outdoor rail-road will remain Fn3 (garden scale - 3-foot gauge - 1:20.3 scale).

The image shows a stylized logo for the Rocky Mountain Pacific railroad. The words "ROCKY MOUNTAIN" are stacked above "PACIFIC". The letters are in a bold, black, serif font. The "P" in "PACIFIC" is particularly large and features a decorative, curved tail that extends downwards and to the left. The entire logo is enclosed in a thin black rectangular border.

2. Rocky Mountain Pacific logo that I designed.



3. The RMP equipment, structures and track moved to storage in the new garage. *Bruce Petrarca photo*

DCC IMPULSES | 4

The indoor railroad plan is up for grabs. My choices are to continue the 1962 version of the Santa Maria Valley Railroad (SMVRR) in HO gauge or to move to an indoor version of my RMP in On30. The RMP is a Depression-era generic Southwest Colorado narrow gauge with a logo that resembles a well-known one [2]. Perhaps the indoor version would feature a more central Colorado locale, so the Gilpin Tram might have an appearance.

The next decision was one of how to control the new layouts. Both had been run with traditional DCC with power and command through the track. Given new technologies, I decided to rethink all things here.

Nope, I didn't have to chainsaw anything, since nothing was really complete. However, I did get most of my NMRA Electrical

ADVERTISEMENT

More Features

FOR THE SERIOUS MODELER

Tsunami²

Be the talk of the club with our newly expanded diesel sound library! We have more prototypically accurate sounds than ever before, including:

- Prime Electronic Bell
- Leslie S3LR and RS3K Airhorns
- Electronic Air Dryer
- Updated GE Dynamic Braking Effects

[Listen Now ▶](#)

Hear the difference for yourself!

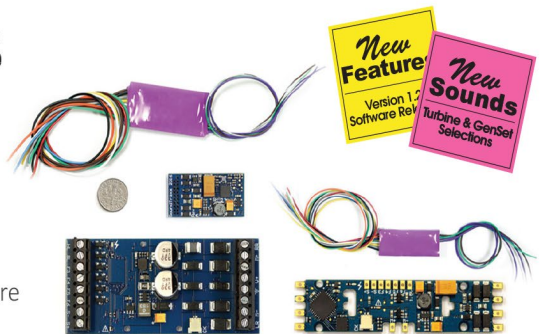

But wait, there's more! We also added new, customer-requested features such as prime mover pitch shift, auxiliary HEP generator, and straight-to-idle.

**All updated decoder packages feature a brightly colored sticker.*

SOUNDTRAXX™

• [INDEX](#)



[SUBSCRIBE](#)
(free)

• [TABLE OF CONTENTS](#)



4. HO benchwork with backdrop in progress for an indoor HO layout – planned to be the Santa Maria Valley (California) Railroad. Note the prototype photos above the backdrop panels. *Bruce Petrarca photo*

and Civil Engineering achievement awards on these two layouts. The layouts were ripped out by their roots. Kinda the same thing, in the end. Gonna miss them.

Indoor gauge/scale

So, the question of what to build indoors raised its head for me to consider.

When I started planning the prior indoor layout, about 15 years ago, it was a very quick thought process. I didn't want something as small as N gauge. I didn't have room enough for O gauge, and Sn3 didn't fit my budget. That left HO.

Great control in a tiny package



**Original
Touch Toggles**

- Touch Toggle™ plug in controls
- Bright clear indication
- Easy setup
- Flexible system

Stall Motors, Twin-coils,
Power, and Servos

Now for Tam Valley Depot
and MRservo too!



**BERRETT
HILL
TRAINS**

Made in the USA



What will they think of next?

www.berretthillshop.com



Servo Switch Machines

- Easy to use
- Low-profile
- Accessory contacts

LEARN
MORE



Infrared Detectors

- Simple installation
 - No adjustments
- They just work!*

LEARN
MORE



Electronics for Operation

- Fast clocks
- Time locks
- Signal controllers

LEARN
MORE

WWW.IASCALED.COM

TamValleyDepot.com

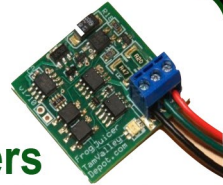

Frog Juicers

Automatic DCC polarity reversers for
frogs on turnouts and crossings.

Servo Switch Machines

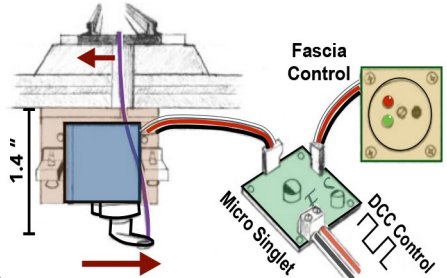

DCC IMPULSES | 6

However, between then and now, Bachmann created a market in On30 (1:48 scale modeling of 30 inch, or 2½ foot, gauge on track of the same gauge as HO). Yup, On30 is not prototypically correct for many, if any, railroads. But it is convenient. There are lots of locos and cars and some track with dimensionally correct ties available at very attractive prices. And it runs like a dream.

In the interim, I have begun regular operations on an O standard-gauge and On30 mixed layout. I have been having a ball at these sessions and really learning to love the On30 scale.

There are so many things to like in On30: an old-west look in a larger size than HO. But they run on HO-sized radii. And narrow gauge operations are a loco and a few cars. Very small trains. The weight of the locos makes for better track contact than HO locos for track power usage.



5. Indoor layout room with cabinets, TV mount and back-drop Masonite removed. Next, the track lights come down.
Bruce Petrarca photo

DCC IMPULSES | 7

Also, six of my eight cars for the NMRA Cars achievement award were built in On30.

So, I am now working on alternative track plans in HO or On30 for the indoor layout. Nothing that I picked up at the National Narrow Gauge Convention in August swung me totally to On30, but it did make a strong impression. More thinking is obviously required.

Command system for the garden

I have pretty much settled on the CVP AirWire system for the garden layout. The power will come from Power-On-Board (POB) battery power. POB sounds so much better for someone of my

ADVERTISEMENT

ADVERTISEMENT



Installing DCC sound just **NOT** your thing?

Trust Traintek for sales and installation of sound decoders from these fine vendors!



"Taking model railroad control to the next level..."



traintekllc.com

Click here for more details...



"Traintek was the way to go!"



www.SBS4DCC.com



SOUNDTRAXX

NCE
The Power of DCC

DigiTrax

DCC Specialties
INNOVATION FOR DCC

MRC
Model Rectifier Corporation

ACCUTRACK II
SPEEDOMETER

SPROG DCC
The DCC Programmer and Control Family

Digital plus
by Lenz

TAM VALLEY DEPOT
Great Electronics for Great Model Railroads



TEAM DIGITAL, LLC
Improving the world of DCC

N - HO - HO_N3 Scale Trains

• **INDEX**



SUBSCRIBE
(free)

• **TABLE OF CONTENTS**

age than “dead” rail. The AirWire system is DCC delivered by the radio, as I discussed in my three-part column series on DCC wireless operation.

It started earlier this year with the March column (mrhmag.com/magazine/mrh2017-03/dcc-impulses). This was chosen for several reasons that were discussed in those columns. A primary one is that our club (PCMRC.org) uses the same system, so there is a knowledge base and some back-up equipment available. So, no matter what I do, one of my layouts is almost guaranteed to be DCC.

Command system for indoors

Now, these decisions become trickier for the inside layout. Trickier, because they are somewhat gauge-related.



6. GE 70 ton loco #70 switching solo on SMVRR in October 2006. *Bruce Petrarca photo*

TONY'S TRAIN XCHANGE

Committed to your DCC support!

Erik Claus
and his trusty
Tony's Reindeer



ESU LokSound DCC Decoders

TDS SuperSonic Mini & Small Speakers

Atheam In-Stock

SALE

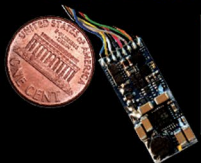

Use these two products together for awesome sound and incredible motor control in even the smallest HO and many N Scale Locomotives.



Accurate, Prototypical Sound & Superior Motor Control. Full Range of Select & V4.0 for N Scale through G Scale Starting at \$85.95

Incredibly Big, High Quality Sound, From Incredibly Small, High Quality Speakers. Don't Forget Enclosures!

Choose From a Huge Selection of HO In-Stock Atheam RTR & Genesis Locomotives!

\$5.95

Starting at \$89.95

[Order Yours](#)

[Order Yours](#)

[View Videos](#)

Do you need a Sound or DCC Installation done?

[Get a quote!](#)



Providing unmatched person to person DCC support for more than 25 years, the kind of service that has made us #1 in DCC.

DCC questions? CALL US! 1-800-978-3472

We'll get you on the right track!

Dec 2017



[INDEX](#)



[SUBSCRIBE](#)
(free)

[TABLE OF CONTENTS](#)

If I stay with HO, I don't think I can achieve my operating goals (three-hour operation sessions) with onboard batteries, at least not based on current technology in a single loco. The 1962 SMVRR roster was a single light Mikado steamer, the first-ever U6B diesel and some 70-ton GE diesels [6].

Even though the SMVRR frequently ran double or triple headers with these small diesels, getting a decoder, radio, speaker, and battery inside would be a challenge, even using all the space in two locos.

This tends to vote for continuing the status quo for HO. DCC on the track, using a NCE PowerCab and three Tam Valley Depot boosters [7]. This layout topography was discussed in my August 2015 column (mrhmag.com/magazine/mrh-2015-08-aug/di_getting-started-in-dcc). The cab bus wiring to allow extra cabs to connect to the PowerCab is shown in [8].

However, On30 opens lots of POB scenarios. Later I'll provide a description of my thought process based on On30 locos with battery power and direct radio control. But first, let's review control and power options.

Through-the-track control and power

There are two broad categories of control systems beyond the ages-old DC (or AC) these days. Digital Command Control (DCC) and everything else. Yes, this is a DCC column, but I'm not being an elitist with that statement.

DCC is the only system that has independent standards to assist in compatibility between manufacturers. The original DCC patents were assigned to the NMRA by the inventor, Bernd Lenz. The NMRA codified them into standards (S-9.1 through S-9.3 at nmra.org/index-nmra-standards-and-recommended-practices).

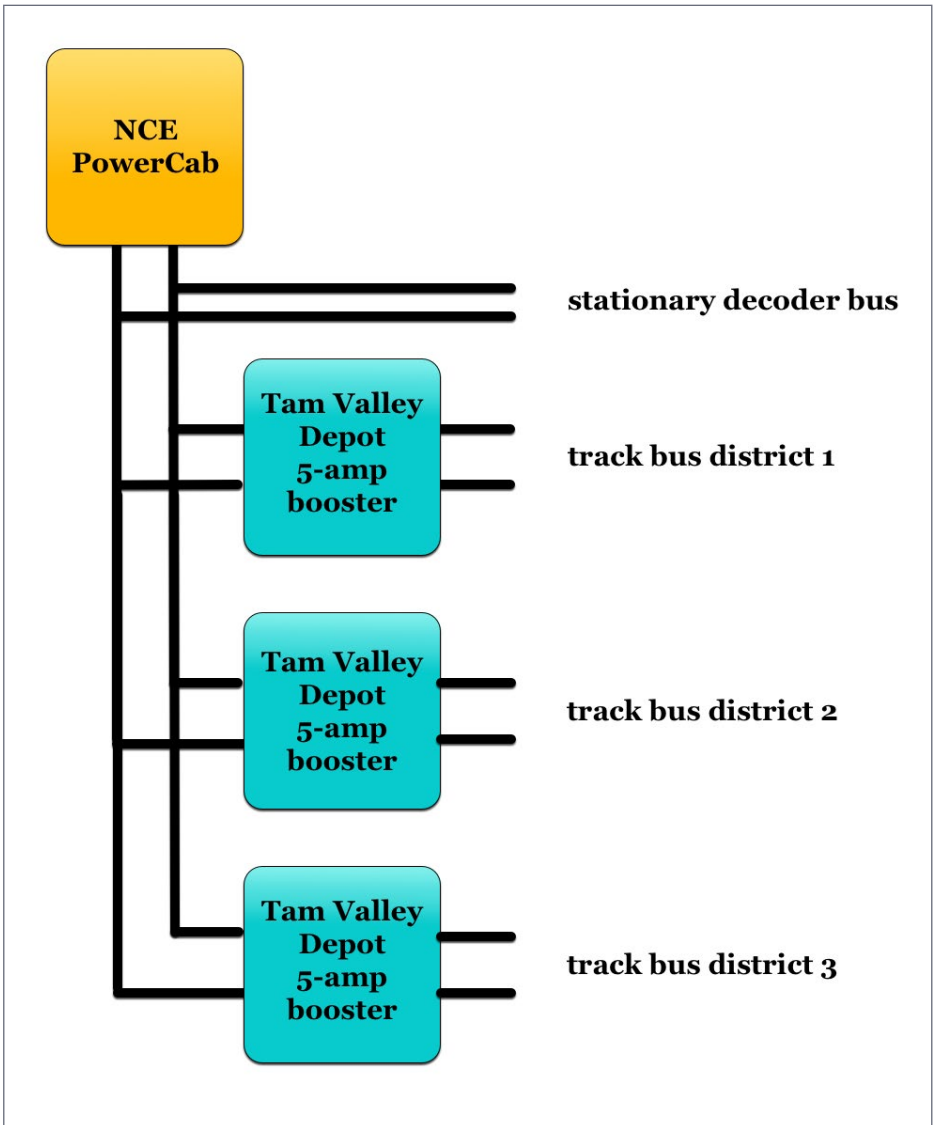

7. Using a NCE PowerCab and Tam Valley Depot boosters to provide three 5-amp districts without the use of circuit breakers. This version provides more power for less money than a five-amp system with three circuit breakers. *Bruce Petrarca diagram*



DCC IMPULSES | 11

You will notice I didn't say, "guarantee," because there are many things that are not covered by the standards. Folks tend to think that standards imply total compatibility. Not so. There are lots of things that are not specified so that various manufacturers can have some personal differences. Also, unless the product has a NMRA conformance warrant, there is no guarantee that the product meets these standards. For many reasons, these warrants are becoming increasingly scarce.

With all that doom and gloom aside, what the DCC standards do is insulate you against obsolescence created by a manufacturer exiting the market. For example, Wangrow was one of the earliest manufacturers of DCC equipment. When Wangrow

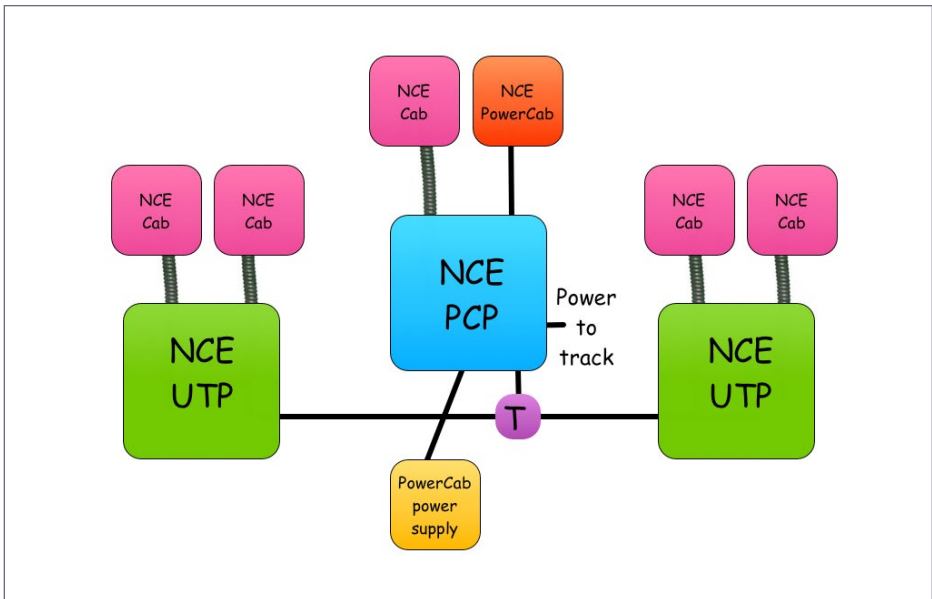

8. Cab bus diagram to allow multiple points for connection of NCE cabs to the system shown in [7]. The PowerCab will not support as many additional cabs as shown in this figure, typically three of the five shown. *Bruce Petrarca diagram*

DCC IMPULSES | 12

ceased operations, NCE stepped in and took over support of the Wangrow systems. Even without NCE's aid, the purchasers of Wangrow products would have been able to buy decoders and other compatible products from various vendors. They just wouldn't have had the repair support and accessories, such as cabs, that NCE provided.

One of the best-known control systems of the last millennium continues today. Dynatrol was released in the 1970s and is still being supported with compatible products (classicdynatrol.com). That said, since it is not a recognized standard, nothing that Dynatrol has done in the last 40+ years is sacrosanct. If they cease operations tomorrow, you, as a Dynatrol customer, will have no ongoing support.

ADVERTISEMENT



RailPro™ Power ON Main Page
Handheld Controller Model # HC-2

Control Locomotive (CO) [Link] Forward

17.6% [Link] Forward

UP 5714 [Info]

Frnt Light Dim Ditch Pop Off Next Page 1

Horn Bell Engine Back Light Exit Page



DIRECT™ RADIO

Click Here to Learn More



NEW Starter Kit
\$399.99 MSRP

- Includes Wireless Color Touch Screen Handheld Controller and 56 Watt Power Supply
- Expandable to Virtually any Size Layout

NEW Locomotive Module
LM-3 & LM-3S



- Direct Radio RF
- Sound and Non-Sound
- New Tiny Size
- 6 Light Outputs

For more information visit our Internet site: www.RingEngineering.com

• INDEX



SUBSCRIBE
(free)

• TABLE OF CONTENTS

DCC IMPULSES | 13

Another non-DCC system comes from Mike's Train House. They chose to make their Digital Control System (mthtrains.com/productline/DCS) similar to, but different from, DCC. They say it is compatible with DCC, whatever that means. The early DCS systems were not very DCC friendly. Recent improvements make them better friends, but even siblings fight from time to time. Since I haven't worked with DCS, I cannot make any more definitive statements. Again, this system is limited to one manufacturer. I'm sure more folks have heard of Mike's Train House than PSI, who make Dynatrol.

Power on board (POB) options



The wheel to rail contact has been the cause of electrical issues since the beginning of power through the rails. With DCC, we're sending both power and commands through the rails. That makes this frailty more obvious. By storing power within the locomotive and sending commands by radio, more reliable operation can be achieved.

The ultimate electric power on board, or POB, solution is 7½ inch gauge ride-on locomotives powered by electric motors

9. Dynatrol cab. *Dynatrol photo*



Southern Digital

WWW.SODIGI.COM

Celebrating 25 Years of serving you !



**Soundtraxx Tsunami
Motor/Sound Decoder**
50% Off while they last

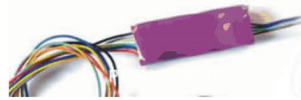
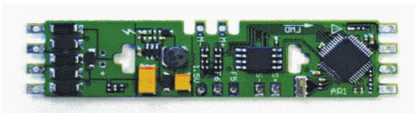

Super Sale

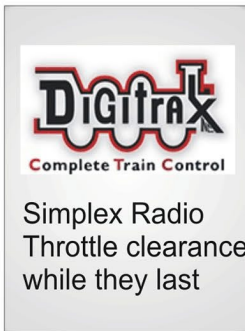

Simplex Radio
Throttle clearance
while they last



Close Out

DT402R
\$165

UT4R
\$99

DCC Conversions, Service & Support

E-mail: sales@sodigi.com (770) 929-1888



• [INDEX](#)



SUBSCRIBE
(free)

• [TABLE OF CONTENTS](#)

DCC IMPULSES | 14

and golf cart batteries [11]. Emerging battery technologies allow us to fit this concept into smaller models. In many ways, On30 is the sweet spot, size-wise. Most of the rolling stock has enough room but does not require huge amounts of power.

I've given a lot of ink (or is it electrons?) to covering this in the last few months, so I'll just do a quick review.

The chart in [12] shows the name of the system, who manufactures it, and what protocol and radio system it uses. As I mentioned earlier, DCC is the only multi-manufacturer system covered. All three of the 900 MHz systems use the same or similar



10. Mike's Train House DCS system. *MTH photo*

DCC IMPULSES | 15

frequencies. Thus, they may interfere with each other or may play well together or not bother each other. If you are planning to use one system in proximity to another, you'll do well to check out the interference issue ahead of time.

I've discussed all the above systems in my columns this year, except DelTang. So, I recommend you learn more, if you are considering this system, by watching a video that my friend,



11. Ultimate power on board (POB): 7½ inch gauge ride-on locomotives. I'm the brakeman in this photo from the Maricopa Live Steamers' January 2013 meet. Yes, we were having fun, even if we hadn't notified our faces. It was late afternoon and the sun was bright. That's my story and I'm sticking to it. *Dick Vogler photo*

DCC IMPULSES | 16

MMR Miles Hale, made with Trainmasters TV (trainmasters.tv/video-player/tmtv-2016-04-act-i). There are concepts that Miles embraces in this video that I do not support, such as the use of unprotected cells, but it does show how one can get a lot into a very small On30 loco and still have room for cab details.

System	Manufacturer	Protocol	Radio
AirWire	CVP	DCC	900 MHz
BlueRail	BlueRail	Proprietary	BlueTooth
Dead Rail System	Tam Valley Depot*	DCC	900 MHz
DelTang	DT Control Systems	Proprietary	Proprietary 2.4 GHz
RailPro	Ring Engineering	Proprietary	Proprietary
S-Cab	Stanton	DCC	900 MHz

12. Various over-the-air control systems for model railroads. *Bruce Petrarca chart*

* The breaking news is that, while Tam Valley Depot developed the DRS system, they are no longer selling it. There was a big splash on their web site in late October about a them discontinuing the line. As I was writing this column, I learned from Pete Steinmetz that he is working to fold DRS sales and support into his Dead Rail Installs business. By the time you are reading this column, you may be able to find and order the DRS products on Pete's website (deadrailinstalls.com).

DCC IMPULSES | 17

So, I can go with HO and keep my DCC system, or I can go with On30 and keep my DCC system, or move to POB and radio control. Perhaps I'll add an addendum to a few of the columns coming up about my thought process as it comes together. What'cha think?

Okay, there is a bit of background on the decision process as it is unfolding in my life just now. I always learn something from seeing what other folks consider and think and how they go about the process. I hope you are learning a bit as I grapple with my ideas.

Please share your ideas with us all. I'd love to hear what you think and see in my thought process. Just click on the Reader Feedback icon at the beginning or the end of the column. While

ADVERTISEMENT

Make LocoNet wiring extremely simple!

ACCU-LITES, inc
Your DCC Center!

**Suitcases belong in your baggage cars,
not under you layout!**

**Introducing the DCC Vampire II ...
this guy does the job of two suitcase
connectors!
And really holds the connection good
too!**

CLICK NOW TO DISCOVER THE AMAZING VALUE!

Dealer Inquiries Accepted

• [INDEX](#)



SUBSCRIBE
(free)

• [TABLE OF CONTENTS](#)

DCC IMPULSES | 18

you are there, I encourage you to rate the column. “Awesome” is always appreciated. Thanks.

Until next month, I wish you green boards in all your endeavors. ☑



Click here to rate or comment on this article

ADVERTISEMENT



www.yankeedabbler.com (856) 312-8084
101 West King, Bellmawr, NJ 08031
In Philly? YD store is 1 mile from NJ end of Walt Whitman Bridge
Visit OUR NEW WEBSITE! SAME GREAT SERVICES & PRICES!

Call us on Pk 727-457-9227 | My Account | Gift Certificates | Sign In or Create an account

SEARCH button

HOME SCALES BRANDS SHIP/RETURNS CONTACT SHOW SCHEDULE NJ STORE HOURS

Featuring New ESU Cab Control Wifi Digital System & Wifi Mobile Control



New Audubon, Iowa Store

Specializing in DCC! ~ The Best for Less! ~ Sales-Services-Installation!
Free Technical Coordination (727) 457-9227 9AM to 9PM EST

CLICK AND SAVE TODAY!

Use coupon code “MRH” for FREE SHIPPING
YD installs DCC or RailPro in your engines

Stop by and meet us at the following hobby shows:
01/27 - 01/28/18
Westspring Field, MA

Click on Show Schedule for info links



• INDEX

• TABLE OF CONTENTS

Model Railroad Hobbyist *Store*

We have *DCC* how-to

VIDEOS

**Athearn BLUE BOX
decoder installation**



DCC DECODED.

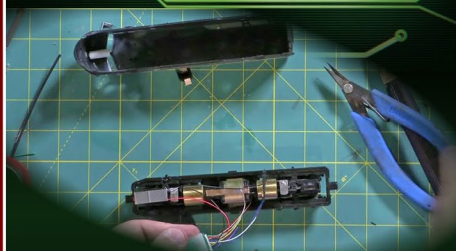

VIDEO DOWNLOAD

Running time: 38 minutes

**Sound decoder
installation video**

By MRH DCC Columnist,
Bruce Petrarca

90 minutes, step-by-step



Available for immediate download!

Shop the MRH Store >>



• [INDEX](#)



SUBSCRIBE
(free)

• [TABLE OF CONTENTS](#)



Complete Train Control

Introducing Wifi Interf

- **Wi-Fi interface to a Digitrax LocoNet for up to four compatible mobile Wi-Fi devices and Apps.**
- **Compatible with most Android and Apple devices running supported throttle apps**
- **Easy Setup and Configuration. A single LNWI works 'out of the box', with no additional configuration required.**



LNWI Loconet
The LNWI allows
to LocoNet and r

Find out how eas

g the LNWI face



et Wifi Interface | **\$79 MSRP**
you to connect compatible WiFi devices
run trains using compatible throttle apps

by it is @ www.digitrax.com/throttleapps/

• INDEX



SUBSCRIBE
(free)

• TABLE OF CONTENTS

ADVERTISEMENT

Because HO is *not* the only scale...



Order your track building tools and supplies from Zn3 to O scale online at:

www.handlaidtrack.com



ADVERTISEMENT

END OF TRAIN DEVICE

NEW SAFETY GREEN

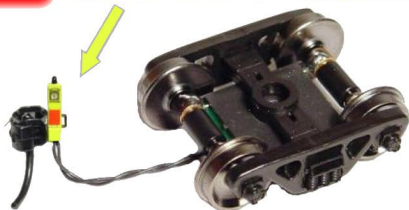

Bright Red Flashing Light!

Installs in minutes!
No freight car modification required!

Patented Technology - US Patent 7,549,609

Does not affect Load!

↓ Car without Load ↓

↓ Car with Load ↓



Click Here to Learn More

RE RING
ENGINEERING

• INDEX

• TABLE OF CONTENTS



GETTING REAL

column

MIKE ROSE
.....



[Click here to rate or comment on this article](#)

MODELING SKINNER'S EDDY, PA PART 2

LAST TIME WE DID MOST OF THE “HEAVY LIFTING” in the remodeling of the general Skinner’s Eddy area, but this time we’ll see the scene really develop into something more complete.

Get the latest Model Railroading News, Tips, Reviews & Opinions



Our iTunes feed has changed search for “Mike And Scotty Live” to receive the latest episodes!

www.themodelrailroadpodcast.com

Hosts:
Scott Mason: www.scottymason.com
Mike Rose: www.mrhobby.com

Don't Miss our Monthly Interviews & Product Announcements

▶ MODELING REAL RAILROADS AND WHAT THEY DO



GETTING REAL | 2



38. The bridge over Tuscarora Creek in Skinner's Eddy as it looks today. It's fun to picture what the great Lehigh Valley Railroad double-track route to Buffalo must have looked like back in the day with trios of Snowbirds screaming over this bridge. LV single-tracked this route eventually, but in many cases the unused span was simply left there to rust as shown here.

The in-use track is to the rear with a ballasted concrete deck, and this scene is what I wanted to capture for the layout. Note how the center of the abutments and pier was made of cut-stone, and then concrete was poured on either side of it. There were actually three tracks on this bridge at one point, since originally there was another siding at Laceyville that started here in Skinner's Eddy, going to a coal trestle.

The old concrete supports for that coal trestle are still there today. It's interesting to view this spot on Google Maps too, as it's all clearly visible.

GETTING REAL | 3

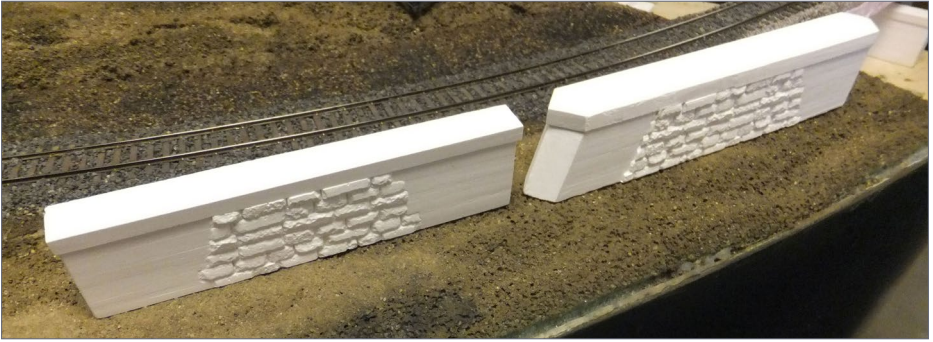

39. How best to model these interesting abutments and pier? New England Brownstone to the rescue! I was able to persuade my friend Russ Greene that this would be a viable product for him, and this “first casting” is the result of that effort. There’s a reason that just about all of my abutments are New England Brownstone, they just look like the real thing when finished, as you will soon see.



40. Here are the abutments colored entirely with Pan Pastels of various shades. Russ turned me on to these extremely useful products for the Towanda bridge piers a couple of years ago, and I’ve used them ever since. I’d estimate that this was about a 20-minute effort, believe it or not.





41. The close-up reveals the level of detail in Russ' casting and how the material lends itself to easy coloring. I was after an abutment and pier that was not nearly in the run-down condition they are today, since I model 1984.



Did you know ...



MRH subscribers

SAVE 10%

**... on the MRH Store &
on TrainMasters TV?**

Click to get 10% off coupon code

(Must be a subscriber to access)



42. There was actually leftover spline sub-roadbed in this area, but it proved ideal for it to simply continue and build the bridge around it, since it was a ballasted deck. Here I'm fitting the New England Brownstone rear retaining casting around the sub-roadbed spline. I find it very easy to accurately cut the castings on my band saw.



[Click here to rate or comment on this article](#)



GETTING REAL | 6

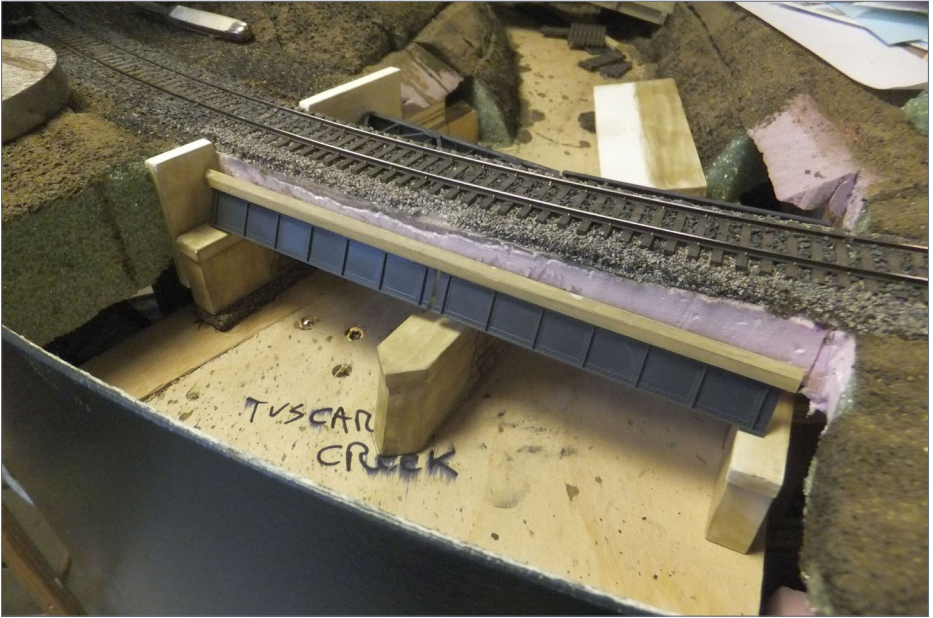

43. With the rear retaining and abutment in place, it was time to build the ballasted deck bridge. Great care was taken to work backwards from fixed points, so in this case, I used Micro Engineering 50' girders as a starting point. The concrete deck sides were fabricated from strip styrene, painted and glued to the bridge, and then I positioned them at the right height as compared to track level, allowed for bridge shoes, and that determined the abutment height. Much trial and fitting ensured a good fit.



[Click here to rate or comment on this article](#)

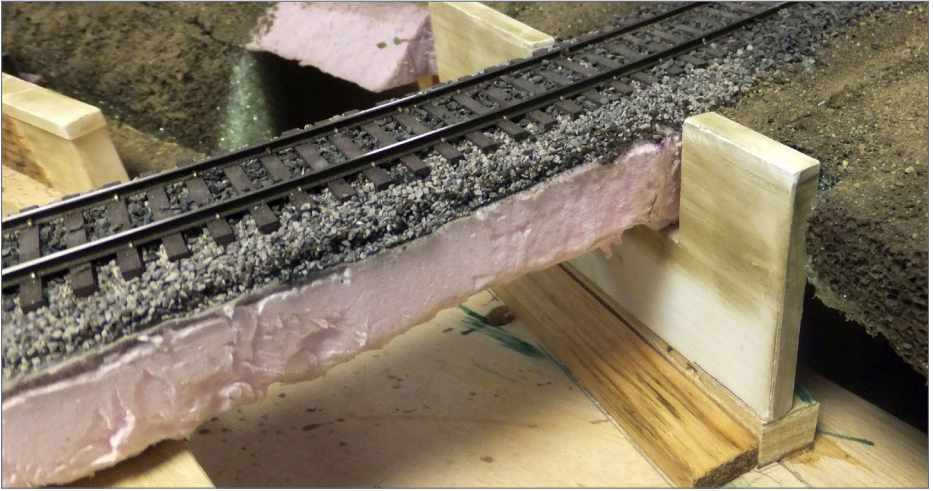

44. Different thicknesses of wood shims were used to achieve the correct heights for the various pieces.

When talking
to hobby
vendors,
please
remember to
mention MRH.

ADVERTISEMENT

**CRAFTSMAN
KITS**

Our instruction manuals are second to none!
CHECK IT ALL OUT AT
WWW.RUSTYSTUMPS.COM
THE QUALITY IS INSIDE BECAUSE OUR NAME IS OUTSIDE



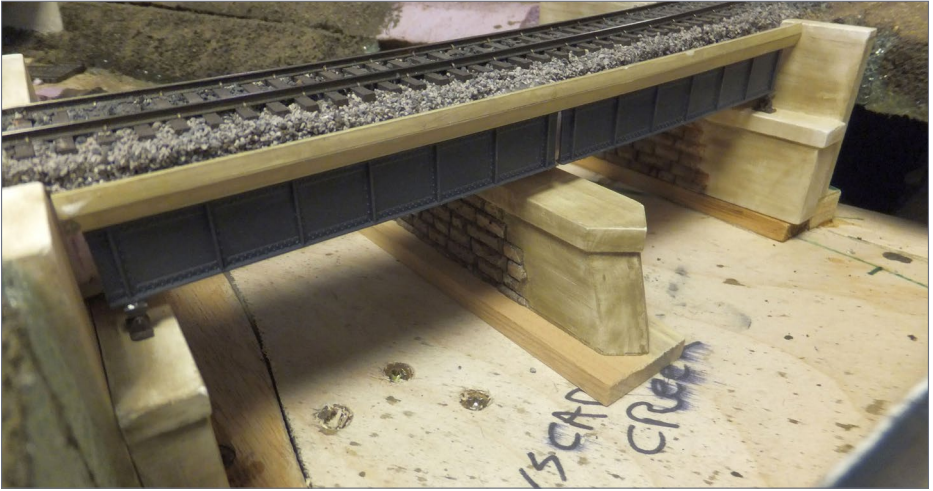

45. Note how the bridge shoe height is an important part of the measurement process.

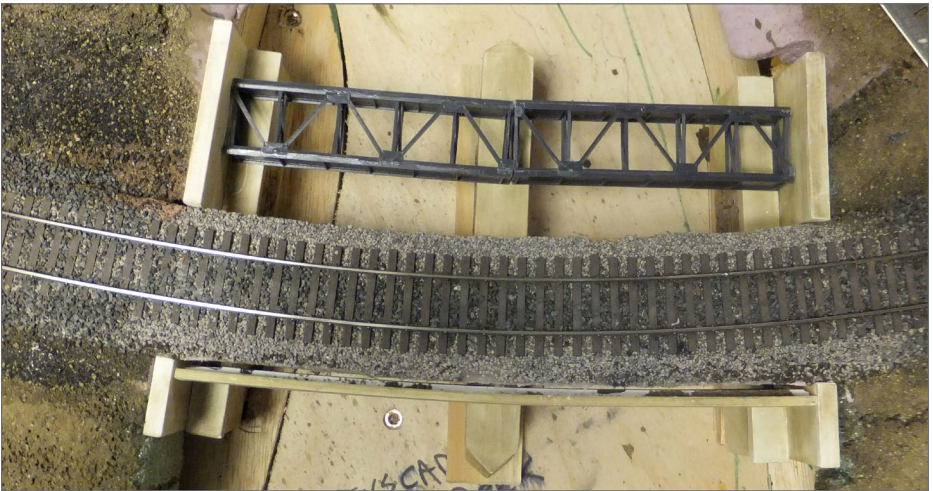

46. Since this bridge is on a curve (both prototype and model), it's critical to get the straight girders right in relation to the track, since the concrete deck would not be curved. I also had to build Micro Engineering bridge sections to fit as shown above the tracks. That is the abandoned bridge segment as seen in the prototype shot.

ADVERTISEMENT

On exhibit this holiday season at The Disney Family Museum, SF



Planning a holiday layout?

3rd Plant 3D CAD
The ultimate track planning software

El Dorado
SOFTWARE



ADVERTISEMENT



ROLLING ROADS

SPEEDOMETER For Speed in Real Time!



Analogue
or digital

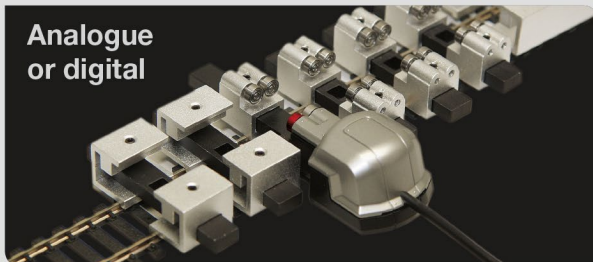

CLICK HERE

Bachrus inc
RUNNING ON QUALITY

www.bachrus.com
Hannon, ON Canada

• INDEX



SUBSCRIBE
(free)

• TABLE OF CONTENTS

GETTING REAL | 9

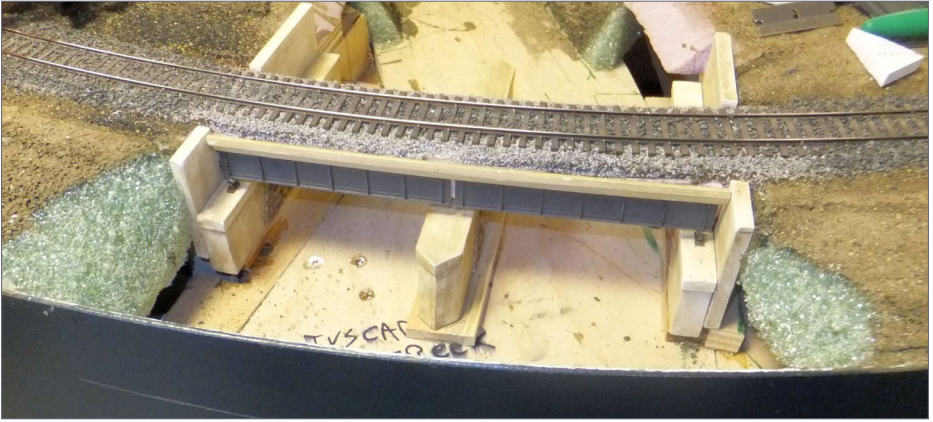

47. Once the proper shim height had been determined, I knew how far down to cut out the fascia. I also pared-back the embankments, as this spot represented the creek flaring out to empty into the Susquehanna River (represented by the aisle).

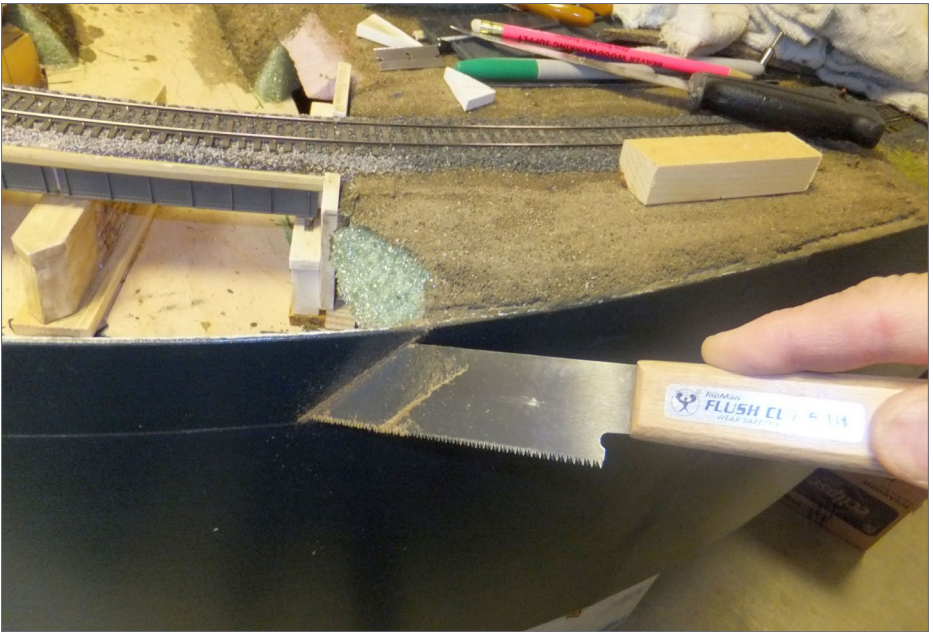

48. Side angle cuts were done by hand with a flush-cut saw.

GETTING REAL | 10



49. The horizontal cut was easily made with an oscillating “vibro saw.”



50. The removed fascia will permit a broad side view of the bridge and water.



51. Small blocks of scrap foam were cut, painted, and coated with dirt as usual to complete the embankment up to the fascia.

***TrainMasters TV is part of
the MRH family.***

***TMTV members not only get great network TV level
videos, they help pay for MRH and keep it free ...***



52. After using tinted Sculptamold to create the stream bottom and bury all the shims, dirt was applied as usual. I then masked off the bridge, abutments, and surroundings and sprayed the stream bottom Camouflage Brown to give a muddy depth to the bed. Shrubbery has also been applied to the stream's banks.



53. The left hand side of the creek is essentially a “dry wash” in my season, and is no doubt wet in the spring, so a lot of vegetation was placed on that side. At this point we’re ready to pour the water. At the top of the photo on the left you can see the pre-rusted abandoned spans to be installed later.



54. After the water pour, still wet! Once the Envirotex Lite cures we can proceed to install the rest of the bridges, and detail the scene.



55. The road bridge and abandoned span are in place and the heavy vegetation seen on the prototype has been added to give the creek a grown-in look. This view also shows how the ballasted deck look has been created.

GETTING REAL | 16



56. Note the old cinder ballast leading up to the abandoned span, this will be continued on the other side as well.



57. The grain mill in the distance is unfinished (the top part is just a cardboard mock-up!) and is actually on another section of the layout, yet it seems to “work” in this shot as a background structure.



58. A view “standing” on the ballasted track portion of the rail bridge, with the Route 6 road bridge in the distance.



[Click here to rate or comment on this article](#)

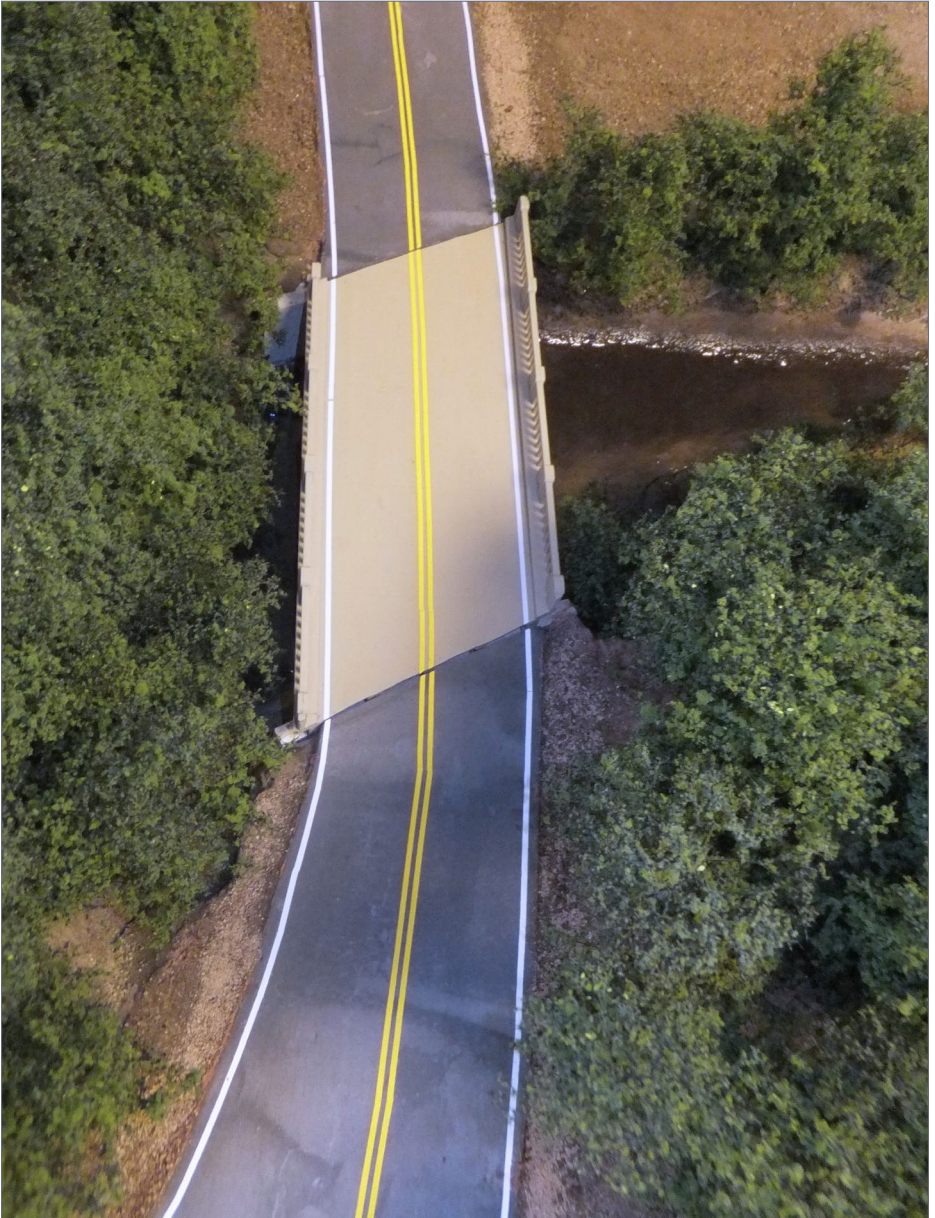

59. The “Google Maps” view overhead shows the juxtaposition of the road, creek, and how the creek dies into the space behind the bridge.





60. Somehow the old rusted pick-up in the as-yet-ungrassed yard felt right to me. It received the same iron-bearing two-part rust system treatment as the abandoned bridge girders.



[Click here to rate or comment on this article](#)



61. The completed scene, showing another modified Athens house on the left, yet another former Athens house on the right, and the installed Table Rock Hotel. I built the sign based on artwork that Rich Cobb provided, and added the Coke machine and concrete porch to the hotel, but this scene would simply not have been possible without him.

Nothing here is complete, but it's a perfect example of what I call presentable. I can run trains through here now, and it feels entirely right. Future work includes lots of detailing (homes need mailboxes, the fuel dealer needs to be built, Whipples needs fencing all around, etc.). I'll likely not get around to that any time soon because there are entirely unfinished areas of my layout at Ransom (future paper mill) and Tunkhannock, so I'd better get busy. Besides, rumor has it that a substantial addition to the basement will result next year in a whole new area of layout to build!

Discover the wonder of TrainMasters TV ...

FREE peek >>



Holiday special pricing in effect



www.trainmasters.tv



TRAINMASTERS.TV



Model Railroad Hobbyist | December 2017 | #94

WHAT'S NEAT WITH KEN PATTERSON

KEN PATTERSON

column



Click here to rate or
comment on this article

KEN LOOKS AT DIGITRAX WI-FI, WI-THROTTLE, UP TURBINES, AND TIER 4 GEVOs ...

THIS MONTH, DANIEL COOMBS WILL SHOW US how to install the Digitrax LNWI Wi-Fi system on my layout and how to download the Wi-Throttle to a cell phone which then becomes our layout throttle.

We look at Union Pacific's gas turbine fleet, covering 1952 through 1969 with 65 various turbines in three design styles, plus the models available in HO scale From Athearn and ScaleTrains.com.

For photography this month, we design a Christmas card for MRH. We also look at the new ScaleTrains.com Tier 4 GEVO GE locomotives, one with sound and one without.



Also see the new "What's neat
this week" weekly video podcast!

**WATCH
NOW** >>

▶ PHOTOS AND VIDEO OF SUPERB MODELS

• INDEX



SUBSCRIBE
(free)

• TABLE OF CONTENTS

Digitrax LNWI



1. Daniel Coombs set up a great addition to my Digitrax DCC train control system. Digitrax has created a digital Wi-Fi interface – the LNWI LocoNet Wi-Fi Interface which lets you control trains on a layout using your cell phone as a throttle.

2. (Top right) We mounted the unit on a small piece of plywood under my DCS-240 command station. It plugs in to a wall outlet and connects to the Digitrax LocoNet with the 6-wire phone cord supplied in the kit. Once it's powered up, it is ready to go.

The next step is to download the cell phone app from the APP Store. WiThrottle Lite is the app Daniel shows us how to work with in this month's video. It has 28 functions, forward and reverse, and a slider to control speed on a clear and easy to understand display. Once you have downloaded the app into your device, go to Settings and link up to the Wi-Fi system by selecting DTX1-LnServer_XXXX-7. The XXXX is a serial number that will be displayed on your screen specific to your unit. That's it.

WHAT'S NEAT | 3



Also see the new "What's neat this week" weekly video podcast!

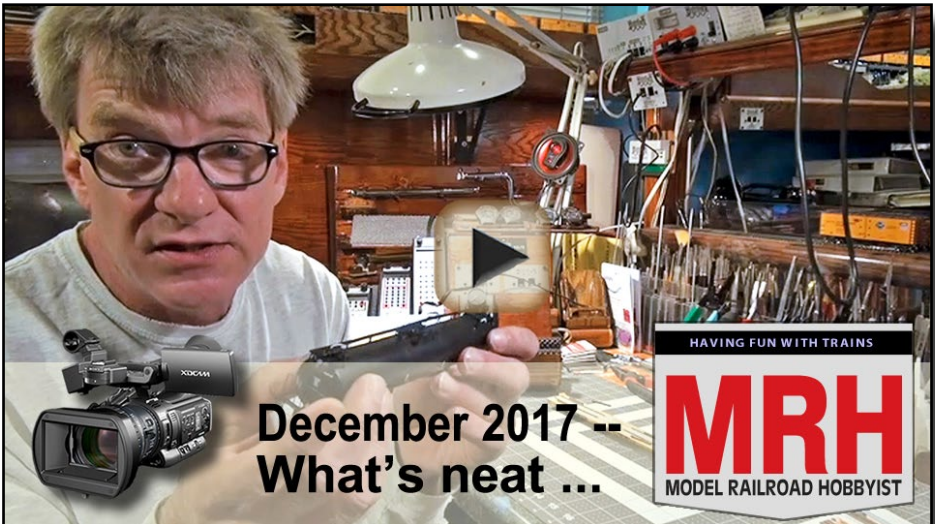

Playback problems? [Click here ...](#)

• [INDEX](#)



SUBSCRIBE
(free)

• [TABLE OF CONTENTS](#)

WHAT'S NEAT | 4



3. ScaleTrains.com sent us two of their HO scale Tier 4 models. One in the highly detailed Rivet Counter line, and the other the simpler Operator series model.



4. The Rivet Counter model is loaded with exterior details, grabs, wipers, window inserts, and full cab interior. It's tricked out and comes with full sound. Features include see through screens, roller bearings that spin, and a LokSound Sound decoder with all the regular features.

WHAT'S NEAT | 5



5. The Operator series model has fewer hand-applied details. For the modeler who wants to apply his own scale parts, holes are already drilled for grab irons. The Operator model runs well and is ready for a sound decoder and speaker, with a DCC 21-pin plug. I photographed these models in full sunlight to clearly show the clean paint work and all the details applied to each Tier-4 model.



Also see the new "What's neat this week" weekly video podcast!

**WATCH
NOW >>**



**Click here to rate or
comment on this article**

• [INDEX](#)



SUBSCRIBE
(free)

• [TABLE OF CONTENTS](#)

WHAT'S NEAT | 6

Christmas card ideas using your models





6-7. (Left top and bottom) This month we design a Christmas card photo in less than 45 minutes, pulling various models off my layout and moving them outdoors for a snow scene set-up. Every year around September or October I design three or four Christmas theme photos for the manufacturers I represent, or for various magazines who request them.

For example, last year I shot a cute trolley in O scale with ceramic houses and buildings all lit to look bright and pleasant for a Christmas train set box art project that Bachmann was designing.

8. (Above) This past October, I set up the *Model Railroad Hobbyist* Christmas card photo by laying Code 70 Micro Engineering track on a piece of foam painted white. The track was ballasted, and sprayed with flat white spray paint from a can. Once this dried, I set up two Walthers grain elevators in the background along with 20 or so wire trees. The feature train is the California Zephyr, using Broadway Limited passenger cars and Athearn F-units. The track was powered during the outdoor shoot under winter clouds, with the locomotive headlight lit. I covered the entire scene – track, train roofs, etc. – with sifted plaster.

WHAT'S NEAT | 8



9. Here is the final photo.

After shooting for about 15 minutes, I hosed off the buildings and foam scene to flush away the plaster. The train wheels were cleaned with Q-tips and dusted off outside with a dry paint brush before returning the equipment to the humid indoor layout room. This is important, as plaster will stick to the model indoors as the warm, moist air in the room condenses on the cold plastic. I learned this clean-up trick the hard way. Try it yourself. Shoot a quick snow scene on your layout and design a photo for this year's Christmas card for your family and friends. It's a fun way to share your hobby along with pleasant season's greetings.



[Click here to rate or comment on this article](#)

Have you seen this?

**CHECK IT
OUT!**



kenpatterson.com

click here to ...

Visit Ken's website

**Ken Patterson
reveals his modeling
secrets on video!**



It's turbine month!



10. Union Pacific was on the cutting edge in the 1950s and '60s with its fleet of mainline turbine locomotives. Turbines burned heavy Bunker C fuel that was heated to burn cleanly in a jet-type gas turbine engine which turned the generator to power the electric motors in the trucks. The turbines also had a diesel engine on board to power the unit in yards. The thirsty high-power turbine was only powered up for mainline freight service. Turbines were known to burn 300 gallons of fuel in an hour while standing still, and the railroad figured this into their design.

The standard turbines, also known as slabs, were built in 1952 and 1953, ten units numbered 51-60. They were rated at 4500 HP. These have large air intakes along the sides of the units and on the roofs. Athearn offers two variations of the standard turbine. #52, seen above, was one of five of these turbines



with Farr grilles on the sides of the locomotive – these are etched metal on the model. The screens were used to reduce the dust and dirt pulled into the unit’s jet turbine and were removed by 1955.

11. (Above) Standard turbine #57 was the first locomotive on the Union Pacific system to receive silver paint on its trucks. It is seen here with louvers along the sides of the locomotive replacing the Farr grilles. The 51-60 series turbines received fuel tenders around 1955 to increase their range.



[Click here to rate or comment on this article](#)



WHAT'S NEAT | 11



12-13. In 1958, UP ran two turbines back to back for six months. Turbines 59 and 60 became a 9000-horsepower set with a fuel tender coupled between the units. All the standard turbines were retired by 1964.

WHAT'S NEAT | 12

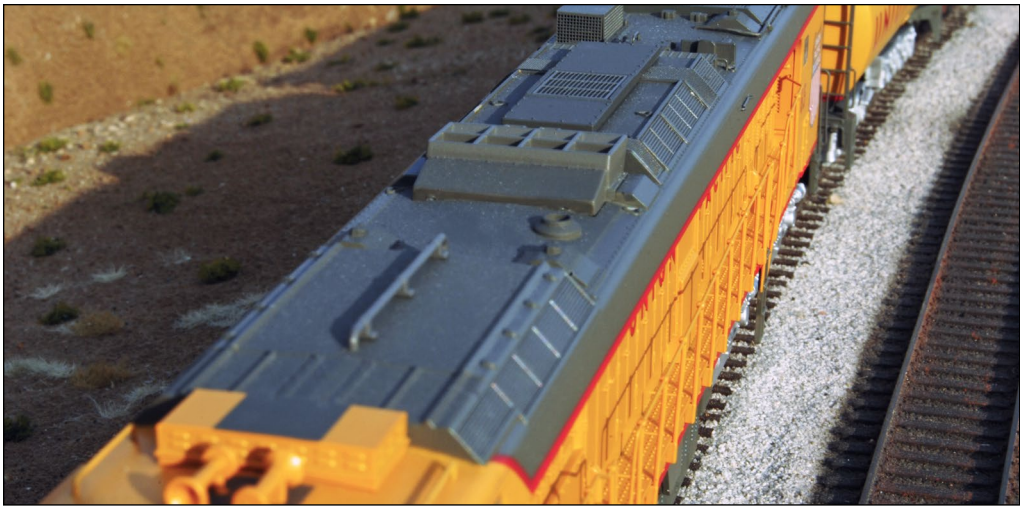

14. (Top) The veranda turbine was developed with all the experience learned from the standard turbine.

15. (Bottom) The verandas had most of the air intakes moved from the side of the locomotive to the roof in an attempt to get cleaner air into the unit.





16. The verandas had walkways built along the sides, with doors on the long hood for easier access to the inner workings of the locomotive. Rated at 4500 horsepower, UP had 15 of these units, numbered 61-75. These units also received fuel tenders around 1955, again to increase the range of the units.

***TrainMasters TV is part of
the MRH product family.***

TMTV members not only get great network TV level videos, they help pay for MRH and keep it free ...

WHAT'S NEAT | 14



17. The veranda turbines were retired by 1964 and traded in to GE, which used the turbines' trucks when building the U50 series locomotives (above) with two diesel prime movers aboard (below).

The super turbines, the "Big Blows," were developed out of all the research from the veranda and standard turbines. The super turbine was manufactured between 1958 and 1961 and was rated at 8500 horsepower. Union Pacific received 30 of these, in two orders of 15. They were numbered 1-30. ScaleTrains.com has recently introduced this model in HO scale. The side-by-side photo shows the Rivet Counter and Museum Quality series models loaded with roof detail on both units.



WHAT'S NEAT | 15



18. #26 is on display. This is the ScaleTrains.com Rivet Counter series model. It comes DCC- and sound-ready, with 21-pin plug and play connectors. Its exterior detail is just fantastic with super sharp paint and lettering. This model represents the second order of 15 units.

19-20. (Right top and bottom) #9 is ScaleTrains.com's Museum Quality model. It comes with full sound in each of the power units, made by LokSound. The lead unit has the sounds of the Bessemer 8-cylinder diesel for moving the unit around a yard with the turbine shut down. The second unit has the jet turbine sound system. The model has sensors in its trucks to detect turnouts – and plays wheel/flange sounds while passing through them. It's a pretty neat feature. #9 also has an operating turbine fan visible from the rear of the unit. Special lighting effects include a lit dash board, (right bottom) ground lights above the front trucks, and class lights that can be changed from green to white and red. A walkway light is installed between the units, and there are operating headlights front and rear.

WHAT'S NEAT | 16



• [INDEX](#)



[SUBSCRIBE](#)
(free)

• [TABLE OF CONTENTS](#)

WHAT'S NEAT | 17



21. The side doors on the turbine unit slide open to expose the inner workings of the modeled turbine engine. Scaletrains.com also offers two types of fuel tenders, a C23 riveted shorter tender and a C24 smooth-side larger insulated fuel tender. UP operated both types and mixed them among units as time went on.

SoundTraxx announced a new turbine decoder in November that includes the sounds of the standard turbine, the veranda turbine, and the super turbine. Each of the three types has a distinctive sound. In this month's video, I demonstrate the Soundtraxx Super Turbine sound system in the Rivet Counter #26 turbine and the LokSound turbine decoder in the ScaleTrains.com Museum Quality #9 turbine side by side, so you can hear them both for the first time anywhere in the model press. They both sound fantastic.

WHAT'S NEAT | 18

Drone footage: Modeling ideas from above



22. This month we are starting a new series of drone videos in What's Neat. Steven Conroy is our drone pilot, with some fantastic footage of Amtrak from the cliffs above the ocean along the Southern California coast. This video will answer all the modeling questions of how your coastal scenery should look. Thank you, Steve, for sharing your flying skills. Also check out our weekly video podcast giving you the latest model railroad news on the internet (Search for What's Neat weekly podcast on Youtube. Ken's monthly MRH YouTube programs can be found at youtube.com/playlist?list=PLBfdQkX57PXzvHde6X951tThXjpwiv B.



[Click here to rate or comment on this article](#)



Also see the new "What's neat this week" weekly video podcast!

WATCH NOW >>

• [INDEX](#)



SUBSCRIBE
(free)

• [TABLE OF CONTENTS](#)



MRH MARKETPLACE

CROW RIVER PRODUCTS

**New "O" Kit 335 B
FLOOR MODEL DRILL PRESS
SECOND IN A SERIES OF
VINTAGE MACHINE TOOLS**

17 Pewter Castings.
For Overhead Belt
Available, No. O-53
or Motor Conversion
(Available Dec. 2017)

Price \$28.00
Made in USA



**HO & O Scale Machinery, Derricks,
Engines, Hardware & Waterfront Models**
Pawtucket, RI 02861 Tel 401-723-0065
www.crowriverproducts.com



TAM Industries

"Preserving the Romance"

The highest quality in Display Cases for sharing your excitement of Model Railroading. We manufacture Display Cases for all gauges of Model Railroading, from "G" to "N". Custom Sizes are available for some styles.



Visit us today at: www.TAM-IndustriesOnline.com

Where the Rail Meets the Sea...



CRAFTSMAN KITS & BUILT-UPS
HO - O - N Scale



NEW! H148-HO Police Boat "Lannan" Tug Exeter
www.seaportmodelworks.com

Click here for our website:

Kadee



Coupler Conversions

Newer models with factory knuckle couplers are easily converted using the Kadee® #148 Whisker® Couplers.



**Conversion Info
Click Here**

MRH MARKETPLACE | 2

LOOK
at what's new at
Black Cat this month

Click here for
our website

Northern Pacific
HO TOFC flat car.



Black Cat Publishing
(204)489-5005
ajfergus@mymts.net
blackcatdecals.com



THE DCC SHOP
YOUR COMMAND CONTROL SPECIALISTS
www.DCCSHOP.com



Quantity Pricing for
the Layout Builder



HO Brass



WOWSound

Start your model railroad
empire on the right track
with **THE DCC SHOP**

The Little Train Store that is **BIG** on Customer Service!

www.DCCSHOP.com
ph. 208-889-9111



USRA DS Express Box
NWP Redwood Empire



westerfieldmodels.com

BenchWork.com

To build your dreams, You need a plan!
Affordable track planning
Starting at only \$250

CLICK ME to get started!

Imagine that!
Laser Art Products

ITLA Scale Models

York Industries
HO Scale Laser
Cut Wood Kit

CLICK HERE FOR MORE INFORMATION
www.itlascalemodels.com

• INDEX



SUBSCRIBE
(free)

• TABLE OF CONTENTS

MRH MARKETPLACE | 3



Yarmouth Model Works

HO scale resin kits and detail parts

..... U.S.A. MAILING ADDRESS
2014 Holland Ave Unit 617
Port Huron, MI 48060

Tel. 519-633-7574 CANADIAN MAILING ADDRESS
pierre.oliver@elginshops.com 263 Sunset Dr.
www.yarmouthmodelworks.com St. Thomas, ON N5R 3C4



Your #1 source for **TOMA** Benchwork
250+ shapes & sizes!
Built to order benchwork also available! (224)201-9868



P.O. Box 6 Paonia, CO 81428
Ph. 970 527 4586
Made in The USA

Cast resin items for All Scales.
Tunnel portals, bridge piers, abutments,
culverts, and retaining walls.
Trackside details and sage brush tree
armatures.

"FREE SHIPPING see website for details"



Altoona Model Works



Railroad Track Side Structures in O & HO scale
Museum Quality Workmanship

WWW.ALTOONAMODELWORKS.US
814-793-7016

*Please visit our website and
online store!*



21175 Tomball Pkwy Suite 287 Houston, TX 77070
Phone: (281)251-5813
<http://www.logicrailtech.com>
info@logicrailtech.com

HO DIESEL SUPPLY

CUSTOM SOUND LOCO'S-REPAIRS-UPGRADES
Weathered New and Rebuilt Locomotives
Powered Chassis-Trucks-Motors-Handrails-Electronics
Parts Inventory Always Changing
www.hodieselsupply.com
email:gerry@hodieselsupply.com



GOODDEALSDCC

WWW.GOODDEALSDCC.COM



HOME OF THE

PROGRAMMER TEST TRACK SYSTEMS

GARY COHN

GARY@GOODDEALSDCC.COM

Add incredible depth to your layout in less than an inch of space



FREE
SAMPLE
DOWNLOADS

CLICK HERE
for more ideas

N Scale
HO Scale
O Scale

TRACKSIDEFLATS.COM

Backdrops, Background Buildings, Downloads

**MAIN STREET AMERICA
HISTORIC ARCHITECTURE**



**MAIN STREET
HERITAGE**

www.mainstreet-heritage.com

CLICK
HERE
for all
our HO
& O kits

Great Decals!™

FEC, Interstate, Virginian
Railway, & L&N Titles
After Hours Graphics Line
Coupler Gages and More
In O, S, HO, and N Scales



MOUNTAIN SUBDIVISION HOBBIES

www.modelrrsupply.com

FREE USA SHIPPING OVER \$39.00

NCE - SOUNDTRAXX - DIGITRAX - ESU LOKSOUND
SPROG - DCC SPECIALTIES - INTERMOUNTAIN - CMX
BAR MILLS - BOWSER - ATLAS - CIRCUITRON - PECO
RIX - PIKESTUFF - CENTRAL VALLEY AND MORE!!!

Model Railroad Control Systems

Geoff Bunza Project Boards
DCC Occupancy Detectors
CMRInet Compatible Nodes
Layout Telephone Systems
RFID Switchlist Generator
Switch Machines and Drivers

Click Here

2018 Trolley Calendar

Full color cover and 13 B & W photos
East Penn Traction Club
c/o Charles Long
227 Locust Road
Fort Washington, PA 19034-1425
[click HERE to learn more](#)

RULERS-of-the-WORLD

Scale Rulers \$4 each

Over 200+ scales!

Metric or Imperial

www.rulers-of-the-world.com

PRECISION DESIGN CO.

LASERCUT KITS - CUSTOM DECALS

PDC.CA

Authorized *RailPro* Dealer

FREE SHIPPING in the US and CANADA

• INDEX



SUBSCRIBE
(free)

• TABLE OF CONTENTS



1. The triangular Railway Express facility on George Sellios' Franklin & South Manchester has been recently upgraded to showcase George's newly rebuilt Bachmann Doodlebug. A white A-frame wood sign just next to the unit's cab reads "Back Bay Doodlebug Boarding." George has added new details to the scene including



What's new on the **F&SM**

patrons, detail castings, and grease stain drippings where the Doodlebug normally sits idling. The Doodlebug has a working cab light, front and rear marker lights, interior lights, a headlight, and sound. Thom's Custom Trains (TCT) completely rebuilt and re-lettered the model for George.

• [INDEX](#)



[SUBSCRIBE](#)
(free)

• [TABLE OF CONTENTS](#)

BY THOM DRIGGERS



[Click here to rate or comment on this article](#)

Visit the Franklin & South Manchester to see what George Sellios has been up to lately ...

ANYONE WHO HAS BUILT A CRAFTSMAN KIT SURELY knows the names Fine Scale Miniatures and George Sellios. George's Franklin & South Manchester Railroad is an internationally known model railroad.

The Franklin & South Manchester Railroad is located on the top floor of the Fine Scale Miniatures factory building. The HO scale layout is approximately 23' X 42' with four peninsulas. Over each hangs a false ceiling with fluorescent and LED lighting.

Background

George has been designing, creating and making HO scale wood craftsman building kits since 1965. FSM kit boxes come with the familiar printed yellow label and each is filled with accurately sized pieces of wood, lots of precisely detailed castings, and expertly written instructions that even a novice modeler can easily follow.

George released his first kit, the #25 Branchline Water Tower in 1965. His first advertisement appeared in *Model Railroader* magazine in May, 1967. Today, the Model Railroad Hobbyist



1a. The triangular shape of the Railway Express Co. is much more apparent in an end view. The water column at the end of the building services thirsty steam engines while main passenger boarding takes place a few cars deep into the train, at the South Manchester Station shed in the distance. The post office workers load and unload the mail cars at the same time. The arrangement of facilities shows George has put some thought into running passenger trains to a tight schedule on the Franklin & South Manchester.

Store is advertising George's last kit (store.mrhmag.com/store/c12/Other.html), Jewels Series #19, The I.M. Dunn Co.

Retirement

George first started his preparations for retirement by cleaning out all his unused cartons, kit boxing materials, and anything else around the shop that contributed to unwanted dust.

FRANKLIN & SOUTH MANCHESTER | 5

When George has finished filling the last order for the last FSM kit, he says he will say, “Now I can work on my layout full time!” He has never kept an inventory of unsold kits or kit parts. Everything usable got recycled into the next kit. George has



2. George has done away with an old Holgate & Reynolds brick sheet paved road and turned it into concrete using his water putty technique [7]. George also extended the road and sidewalk into the track tunnel, which now allows easy passage into the heart of the South Manchester business district. New road weathering and foliage techniques helped to update one of the layout’s original scenes, from 1986.

FRANKLIN & SOUTH MANCHESTER | 6

been discussing ideas for changes to the layout for years, even before his impending retirement.

Updates and improvements



Now that he's retiring, George has become more fully focused on the layout. One of the first things George mentioned to me was his desire to update and improve his layout scenes. He plans to use suggestions from visitors in making many of the layout changes.

Many visitors are simply speechless when seeing the highly detailed layout for the first time.

The original 1986 South Manchester portion of the layout is where George is starting his improvements. Some of the alterations include replacing old hilly dirt roads with concrete roads. Other changes include transforming overly cracked concrete roads into more realistic heavily traveled ones.

Out-of-era figures will be replaced with a more consistent story line cast of figures as this seems to be what most visitors comment on.

Layout goals

All parts of the layout, whether a section can be viewed or not easily viewed from the aisle, are getting a makeover. One of the things



FRANKLIN & SOUTH MANCHESTER | 7

George has noticed in the many photos and videos taken over the years is how the camera views his structures. When installing certain structures, George often didn't think a certain portion would be visible to the camera.



3. One of the several commuter stops George incorporated around the layout for the Doodlebug, and for railcars and his railbus as shown here, is this new diner stop in North Manchester near the end of the industrial spur track. A custom-built brass PSC railbus upgraded by TCT rounds out the newly added scene. The railbus has a visiting track crew team onboard from the Beaver Meadows division of the F&SM. The motor car has DCC sound and a complete nine-member crew, lots of track tools, a stove chimney using an FSM casting, working headlight, rear marker lights, interior light, and a dog just behind the driver!

FRANKLIN & SOUTH MANCHESTER | 8

George is also changing to Tortoise switch motors as maintenance dictates. He is adding more structure lighting and plans to add working signaling.

George doesn't adhere to the idea of building just to the point that a scene looks "good enough." He has many ideas for portions of the layout, including a new section, and refocusing on other points of interest on existing sections.

Operation is a part of the hobby George has always talked about and now keeps in mind while adding more structures to his layout. Run-through freights, passenger train station stops, and switching moves have become key points for George's thinking.



4. From this angle on Railroad Avenue, it looks like lunch time. The track and local switching crews, along with some patrons from Wanda's Boarding House, head over to the Chateau Diner for its "home-style cooking." Locals claim the Bostonian Burger is the best for miles around. They say it goes great with the Sellios Shake and its chocolate/vanilla/strawberry "weathering" swirl!



Visitors

Viewing the highly detailed Franklin & South Manchester Railroad for the first time can be overwhelming. George and I have some



5. Here we get a better view of North Manchester's newest scratchbuilt structure, the Chateau Diner – directly across Railroad Avenue from Wanda's Café & Boarding house. Wanda's is a nicely detailed scratchbuilt stucco two-story building. George relocated the crossing gate tower across the tracks to make room for the Chateau. The gate tower is a reworked plastic Atlas kit with upgraded roof shingles and FSM casting details.

FRANKLIN & SOUTH MANCHESTER | 10

interesting conversations with visitors, both young and old, during his regular open house mornings.

We work hard to maintain the layout's running status, to the point



we sometimes forget that running trains at an open house can get in the way of having conversations with the visitors. Get engrossed in how would one switch a particular car or industry, and you can find you've forgotten all else for several moments.

Dealing with numbers

The F&SM has structures, structures, and, yes, more structures! In the last year, George has added *still more* new structures to the layout. Some 600+ structures can be found on the layout!

George has spent more than 30 years building the F&SM. Kit design and production took almost nine months of the year.

This left George three months to work on building his empire. However, now that he's retiring, he is dedicating more weeks of each month to building new structures and improving the layout.

One of the most frequently asked questions George is asked at an open house is, "How long did it take to build this layout?" Certainly an interesting question, and the answer is "I've been working on the layout for over 30 years and it is still an ongoing process."



Layout maintenance

With any layout, large or small, maintenance is an issue. The F&SM is no different. From repairing rolling stock to removing dust, George literally “has it covered.” He has a cloth valance he hangs over the layout when it’s not in use.

George and I made a short 1½ minute video to answer this question: youtu.be/yO8oa6bvwmE.



6. Before North Manchester was redesigned, the large curved brick Trainor Industries building was a layout sight block, looking back from Manchester Station, that helped to hide the sun from the large windows that could bleach out layout scenes. The redesign gives a more inviting perspective that was unobtainable before. The scratchbuilt Calendar Press Co., along with the highly-detailed junkyard just beyond it, gives one a reason to press his nose up against the Plexiglass while viewing. By the way, George finds nose prints on his Plexiglass layout guards from time to time – it still makes him chuckle.

LIMITED SUPPLY!

FINAL KIT!



FINE SCALE MINIATURES

FSM is closing its doors after 50 years of business!

Fine Scale Miniatures founder George Sellios with his final kit



ONCE GONE, THAT'S IT!

I.M. Dunn Co. \$280 + S&H



Destined to become an instant collector's item

BUY NOW >>

Brought to you by the MRH Store: store.mrhmag.com

• INDEX



SUBSCRIBE
(free)

• TABLE OF CONTENTS

FRANKLIN & SOUTH MANCHESTER | 12

Visiting the F&SM

George hosts an open house one Saturday a month from April through October. Hours are from 9 a.m. until 12 p.m. Many modelers and non-modelers alike have visited the layout since 1985.

Call George to find out the time of his next open house! (978) 531-9418.

Fine Scale Miniatures, 49 Main Street, Peabody, MA 01960.



7. George is currently focusing his efforts on Steep Hill Road. He had wanted to change the dirt road to a concrete road for a better visual effect, and some of the business owners from Fidelity Storage and the Flour & Grain complained about the commute on rainy and snowy days! George paved the road with water putty painted with Floquil Aged Concrete paint, then weathered it with alcohol and India ink, at 2 teaspoons to 1 pint of 70% alcohol. The new concrete road completes the scene and it looks as if it has been part of the original scene since it was finished in 1986.

FRANKLIN & SOUTH MANCHESTER | 13



8. Fillmore yard is a main aisle layout feature of George's F&SM empire. It was built some years ago but George still finds himself adding and changing details in this aisle quite often. This view puts us "on the wrong side of the tracks" just beyond the great city of Fillmore. Some 13 tracks service local businesses and freight classification for other parts of the railroad. Fillmore also includes a large passenger station and terminal with a small roundhouse plus turntable. All of this fits into an area less than two feet deep and 13 feet long.



[Click here to rate or comment on this article](#)



FRANKLIN & SOUTH MANCHESTER | 14

wall

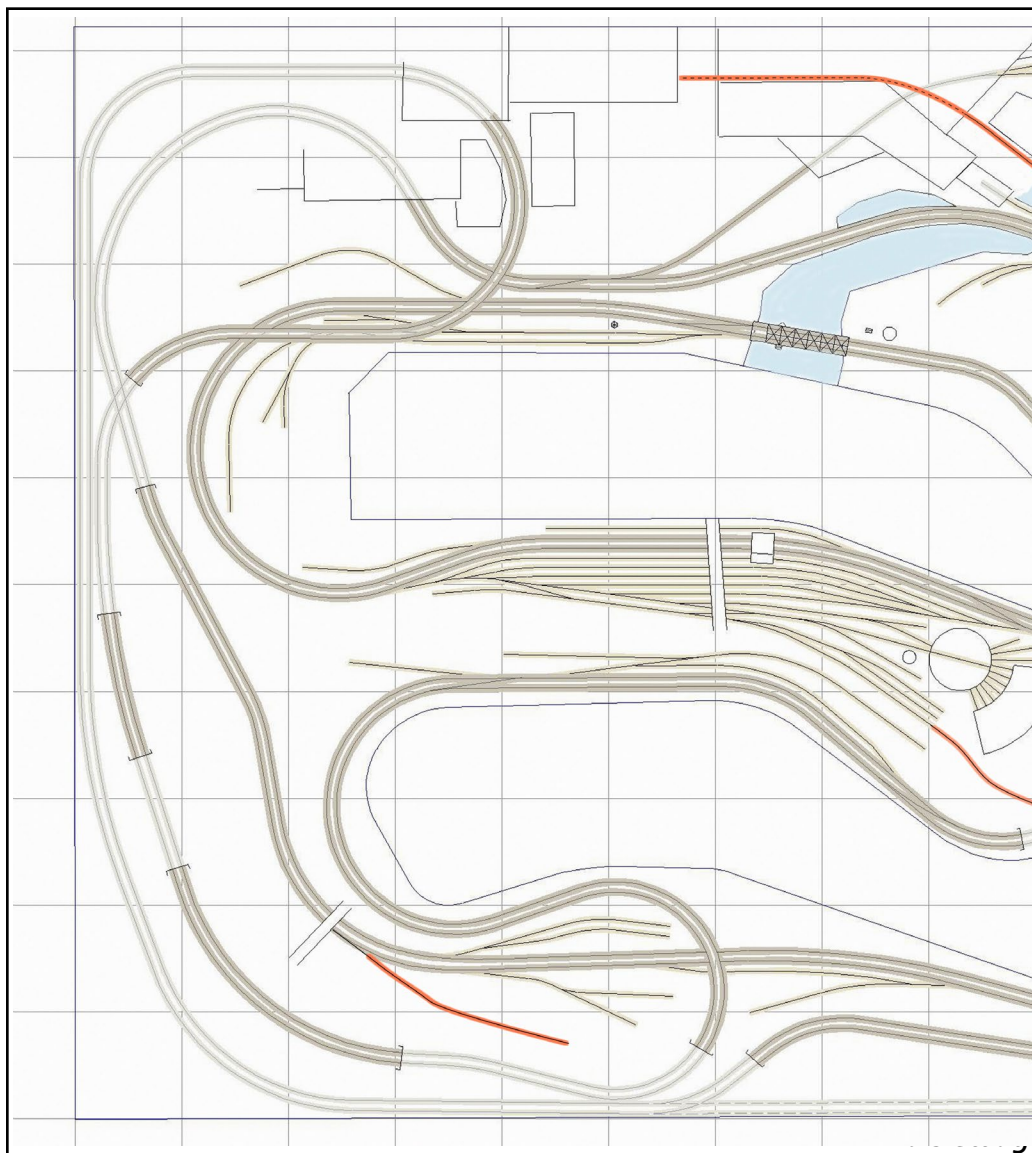

Layout Summary

Name: Franklin & South Manchester

Locale: New England

Era: 1929-1935

Scale: HO standard gauge

Layout style: Multi-peninsula, single deck, continuous run, non-walkaround

Size: Roughly 25' x 42'

Mainline length: 300'

Min. turnout: #8 mainline, #6 yards/sidings

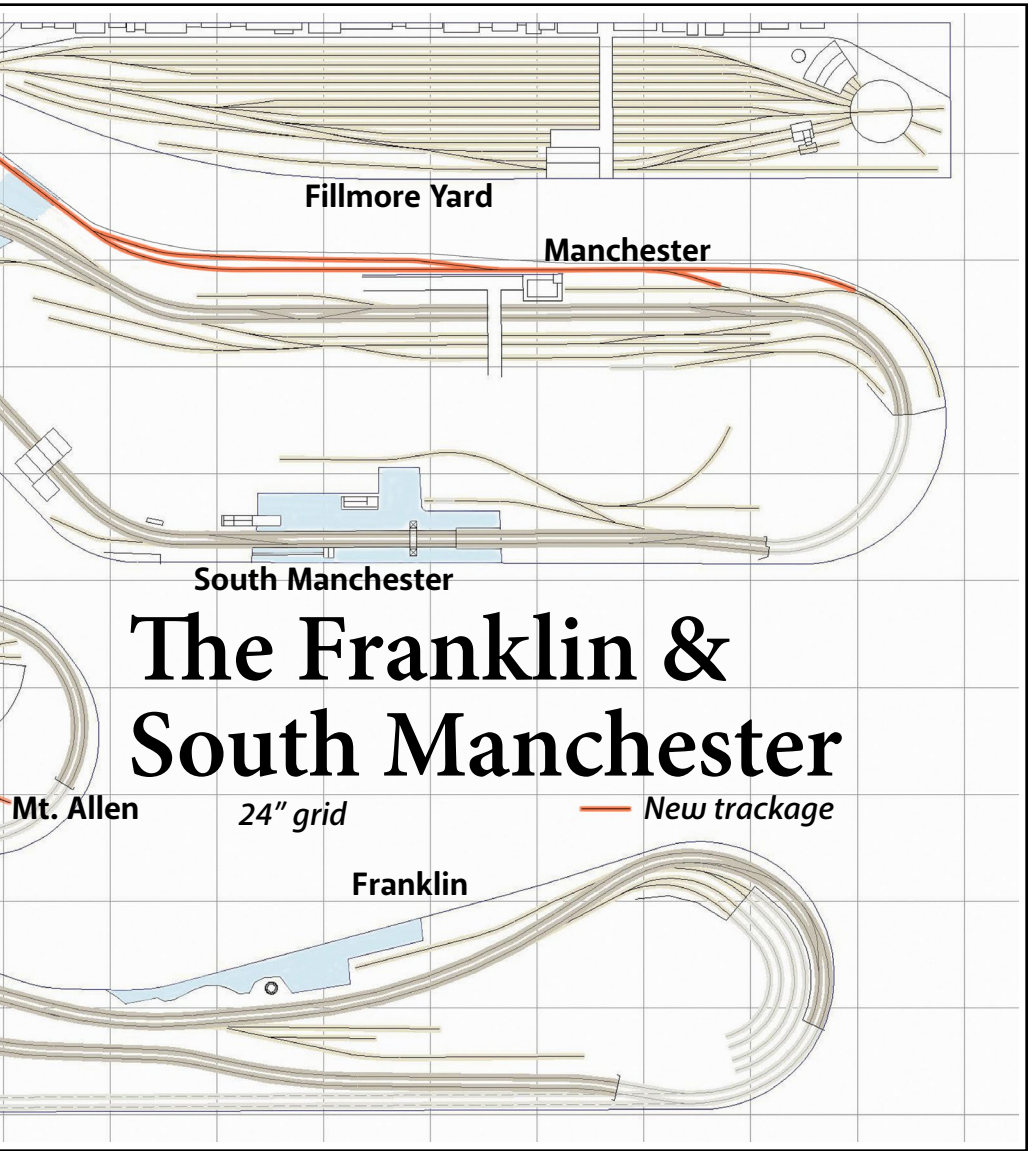

The Franklin & South Manchester

Mt. Allen

24" grid

— New trackage

Franklin

Min. radius: 32" mainline, 18" industrial
Max. grade: 1.5%
Turnout ctrl: Tortoise / Hanks-craft machines
Track elevation: 43" to 50"
Loco control: NCE DCC

Tallest building: 3' (in Manchester)
Scenery: plaster (old areas), foam (new)
Benchwork: T-girder
Layout age: Started in 1985
Oldest area: Manchester

FRANKLIN & SOUTH MANCHESTER | 16



9. The main causeway across to Fillmore is “Doug St. Passing,” named after FoScale Model’s Doug Foscale. George finds Doug to be an excellent structure builder and kit designer and enjoys seeing what original creations Doug will come up next. The granite stone structure next to the overpass is the original Fillmore Station. Rumor has it a modern underground station is being planned on the right side of the tracks, deep in the city of Fillmore itself.



[Click here to rate or comment on this article](#)



10. George used a variety of techniques to build the Fillmore city skyline. He started with some commercial sky wallpaper available from Walthers. Next, he added depth to the clouds using black and white chalk with a stiff brush. George added some 3D effects using poly fiber and cotton glued to the backdrop, which he highlighted with some paint. After that, he added scratchbuilt structure fronts with lots of details. Recently, he finished off the overall 3D look with the addition of various blocks of wood covered with Kings Mill Enterprises brick building paper supplemented with some additional wood and cast details. As one can see, this extra work in adding some depth to a simple flat backdrop is well worth it!



11. Above the cabooses at left, George added a tunnel with an angled mirror and a road to give some depth perspective to the scene near the small roundhouse. There are 3 or 4 mirrors throughout Fillmore Yard to add more depth in the background. George's scenes include lots of little details as eye candy for the viewer.



[Click here to rate or comment on this article](#)

FRANKLIN & SOUTH MANCHESTER | 19



12. One of George's favorite focal points in the city of South Manchester is the Franklin & South Manchester bus and train station. George started this structure by combining many of his wall castings to get this huge grand station. Recently, he has been busy adding lots of lights to all parts of his layout. This station received a Miller Engineering lighted Cracker Jack sign on the back of the roof. On a side note, George has also weathered up a Bachmann sound-equipped 4-4-0 and two Ambroid lighted wood passenger cars (some of George's favorite rolling stock).





13. One of the benefits of working with George on the F&SM RR is getting to test run Thom's Custom Trains customers' foreign road power on the F&SM. Here in Colbert Yard are two such engines: one switching and the other pulling a local freight destined for the town of Mayfield. In the foreground, George has added an abandoned trestle to the original old main line. Why did George do that, you ask? Because he saw a small piece of layout real estate with room for a small structure and it gave him something to do while waiting for his Fine Scale Miniatures metal casting machine to heat up!



14. Colbert Yard (formerly Fellsburg Yard) is a nice-sized yard for the F&SM RR and is a two-man beehive of activity during one of George's rare operating sessions. The visiting Franklin, Hamilton & Essex 2-8-0 brass engine and the Atlas RS2 are "on loan" to the F&SM RR during a motive power shortage caused by the ever-increasing demand for goods and services now that the Depression is fading. George's custom five-track coal-ing tower and operating turntable can be seen here – more visible without engines during the motive power shortage.



[Click here to rate or comment on this article](#)





15. From a higher position, one can get a bird's eye view of the track and topography elevation variations of the Beaver Pond spur track. Engine #18 slowly glides alone upgrade to the I.M. Dunn Coal facility. When viewing the F&SM RR, visitors need to look closely through all the rocky wooded areas of Wolf Hollow and Beaver Meadows to see all the wildlife that lives here. One may find beaver, deer, moose, birds, eagles, fish, and yes – even a couple of out-of-scale small spiders have been spotted!



[Click here to rate or comment on this article](#)



16. A closer view of the rustic light bridge crossing Beaver Pond. Visitors love to see how slowly the engine can creep across this bridge. George is certainly not afraid to model a structure in its death throes like this rickety trestle. By the way, it's rumored that a snapping turtle may live nearby, under this bridge.

Want to help
keep MRH free?
Then click on
Ads!





17. F&SM RR #18, a local 0-8-0 engine out of Mayfield assigned to local service in the town of Beaver Meadows, pulls off the main track at Wolf Hollow's old rickety bridge. This spur track heads upgrade past Beaver Pond on its way to the old I.M. Dunn Coal facility at the top of the hill in Beaver Meadows. Two days after this picture was taken, George installed a switch derail to head off any cars that might accidentally roll down the hill toward the main line.



[Click here to rate or comment on this article](#)



18. Beaver Meadows is home to George's I.M. Dunn kit. It's also the site of several recent changes and upgrades on the F&SM RR. Following the road that leaves the IMD coal facility, you cross the tracks to another scratchbuilt structure, Reid, Murdoch & Co., which George added here after installing I.M. Dunn, his final kit. Reid Murdoch is an old tool sharpening company structure which George moved from the Marthaville area some years ago. George never throws away any of his structures; he decided he could fit this unusually-shaped building somewhere on the layout, and it ended up here. Now you know the rest of the story!

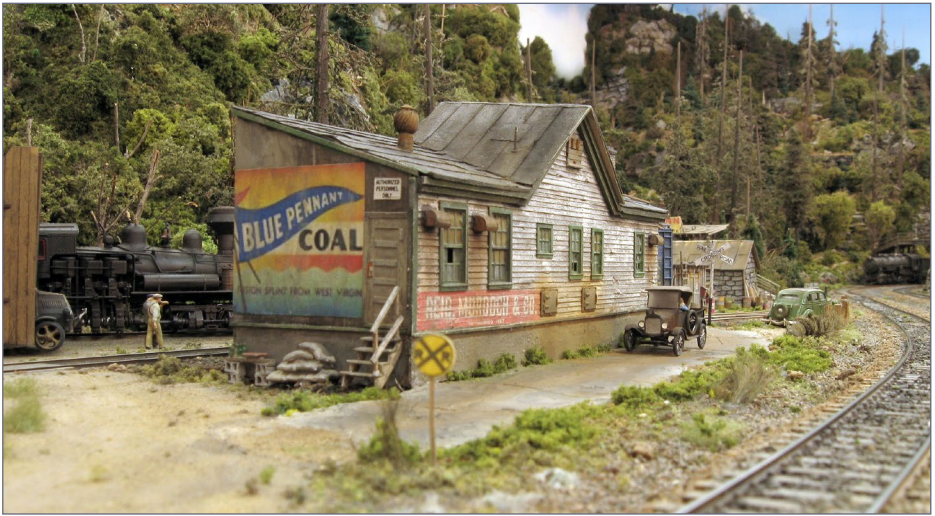

19. Reid, Murdoch & Co. is located in the heart of Beaver Meadows, right in front of George's John Allen tribute two-stall enginehouse. Here George shows that a structure of any shape or size can be used with a little imagination and some scenic blending such as using a road as he's done here. It is also a good thing for the Beaver Meadow Lumber Co. that Reid, Murdoch & Co. sits right next door to sharpen all those teeth on their saws! George placed this building in such a way that viewers don't readily notice the sides or the crude unfinished rear of the structure, one of only three unfinished structures on the F&SM, by the way.



20. On the other side of the main track, George managed to shoehorn in his Jamestown Water Stop kit. F&SM engine #18 makes a water stop while switching out a couple boxcars for the Hazen Boyd Produce Co. The Jamestown Water Stop kit is a high casting count kit and its multitude of castings easily allows it to reside right up front on any layout.



[Click here to rate or comment on this article](#)





21. A trackside photo like this of the Jamestown Water Stop scene, captured with a small digital camera, allows for some very interesting and otherwise impossible low-angle shots. The small phone cameras give access to views that can't be seen any other way. George has been more than generous with people having such small cameras by allowing them to shoot photos of his layout.

Tell your friends about MRH!

**We depend on word-of-mouth to grow
... if you don't share us, we don't grow**



22. This trackside photo of engine #18 in front of the ol' crew and track worker shanty is seen from across the Track One main line in front of I.M. Dunn. This is a photo view that cannot be seen by a visitor at all. Small digital cameras make special shots like this possible.



[Click here to rate or comment on this article](#)





23. From this trackside viewpoint, a photo captures almost all of the 12 structures in Beaver Meadows. George has been upgrading his layout in anticipation of taking more layout trackside photos. What layout can't use more low angle trackside photos like this?





24. This trackside photo of the Hazen Boyd Co., on the left, looks across the mainline trackage to the other side. Over there is the Beaver Meadows Lumber Co. and the John Allen two-stall engine house. This is another angle that can't be seen normally by viewers. Visitors often comment on the massive amount of detail in every view on the F&SM. George is truly a master model builder for the times.



[Click here to rate or comment on this article](#)



25. Yehuda's Heating Co. is the only brick model Fine Scale Miniatures has ever offered as a kit. As far as collectable FSM kits go, this, FSM Jewel Series kit #14, is a rare one. George spent his travel time taking pictures of similar structures and used some other manufacturers' parts to assist in making this kit. Again, it's a very rare structure as far as FSM kits are concerned.

**Use our custom
Google search on the
MRH website to find
topics of interest**

CLICK TO FIND OUT MORE





26. NYC 2-bay hopper car #838075 has unloaded on the trestle and is waiting for the local engine crew to take it out and bring in a new load of coal for the coal-hungry community of Beaver Meadows. The old stone dynamite shed still stands, even though its days of storing dynamite for all the rock blasting



for the railroad's construction in the mid-1800s is long past. Plenty of business hauling coal by the truck load, wagon load, and by the bag keeps this local merchant busy. Electricity was just recently installed in this rural area, so there may be competition for coal in this area soon. ☑



THOM DRIGGERS



Thom is an avid ferroequinologist and has been building models since age of 10. His railroad experiences include working for three different prototype railroads, modeling in five different clubs, working with George Sellios professionally building, repairing, weathering brass/plastic engines and rolling stock for the last 38 years under Thom's Custom Trains thom-customtrains.com. Thom's appreciation for detailed model brass locomotives is also shared by his long time girlfriend

Luba who encourages his brass collecting.



Click here to rate or comment on this article

130,000 have seen this MRH video - *have you?*

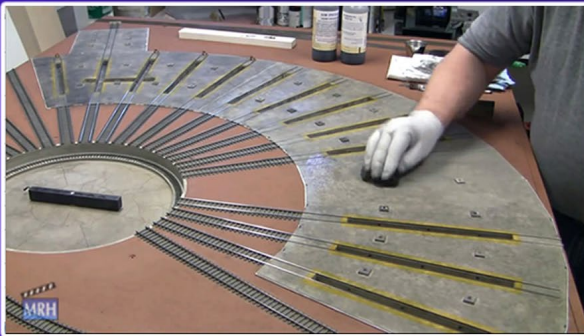

Watch the video now



Did you see this video on TrainMasters TV?

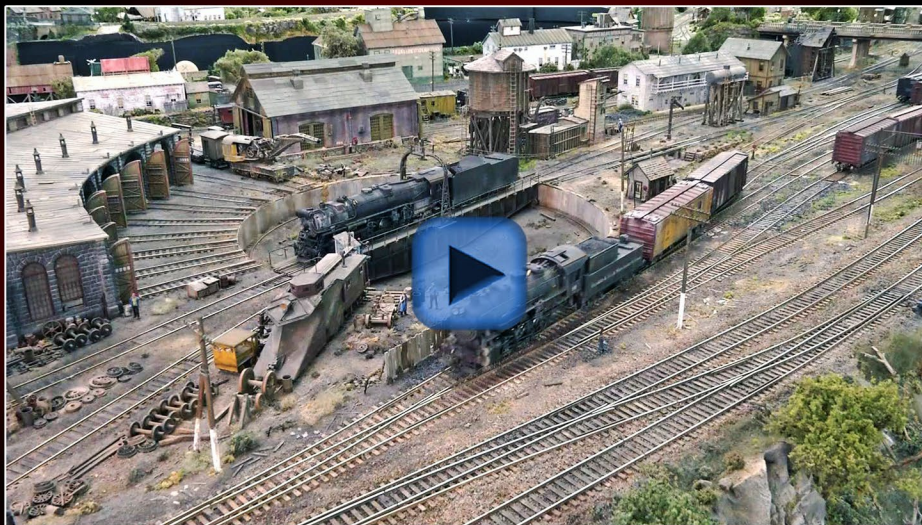

George Sellios' F&SM update!

*We visit with the
the FSM's creator
George Sellios and
catch up on 50
years of modeling
excellence ...*



Holiday special pricing in effect!

Click here to access ...

**You must be a TMTV subscriber to access
(Non-members can watch for just \$1.49)**



Become a member!

• INDEX



SUBSCRIBE
(free)

• TABLE OF CONTENTS

Merry Christmas



Daniel

Ken

Mike R

Bruce

Jack

Patty

Nick

Joe B

Don

Richard

Tony

Rob

...as from MRH!

Paul

Dave

Jean-François

Jim L

Chris

Joe F

Larry



Les

Mike D

Ray

Jeff

YES, IT'S A MODEL
Photo by Ken Patterson



[Click here to rate or comment on this article](#)

• INDEX



SUBSCRIBE
(free)

• TABLE OF CONTENTS



One Module Challenge

Honorable mention

BY JIM MOE

TOMA contest entry inspired by memories of prototype railroading around the Duluth, Minnesota area ...

I WAS ALREADY IN THE PROCESS OF DESIGNING some HO scale modules for my future home layout when I became aware of the TOMA contest, so I decided the twin ports area of Duluth, MN and Superior, WI would be my entry into the contest.

• [INDEX](#)

• [TABLE OF CONTENTS](#)



Click here to rate or
comment on this article

Having grown up in northern Minnesota, Duluth holds a special place in my memories. I remember childhood visits where I was in awe of the huge ships entering or leaving the channel right beside the Maritime Museum. I was also in awe of the DM&IR 2-8-8-4 Yellowstone steam locomotive housed in the Transportation Museum in the former Union passenger depot. Furthermore, my wife SuzAnne and I were married in Duluth over 20 years ago.

Overall TOMA layout approach

The two most dominant commodities brought to Duluth/Superior in the past by rail, and shipped out by boat (Great Lakes vessels are called boats regardless of size) were grain and iron ore. I've included one terminal-sized grain elevator on the first TOMA module section. The iron ore dock will be a separate stand-alone module in Phase Three of module construction.

For the module benchwork, I chose to purchase the Kam Kconnect brand of tables, even though I have all the tools and experience needed to build benchwork. I really like their light-weight and sturdy construction, and their patented locking

1. The 2-8-8-4 DM&IR Yellowstone locomotives that pulled iron ore unit trains from mines in the Northeastern Minnesota iron range to holding yards near the Lake Superior ports helped inspire this layout entry. *Special thanks to Jeff Lemke who put together the Twin Ports History page (twinportsrailhistory.com) and allowed photographs from his site to be used for my contest entry.*



ONE MODULE CHALLENGE | 3

system that ensures perfect alignment every time they are assembled. I also wanted to use them to show that a beginner could buy ready-made lightweight and portable modules to build a layout.

I am using the special custom-built drop-down modules to allow for the depth needed for a waterfront scene (see the Kam Konnect sidebar). I use additional foam sheets for the scenery base, rough Plexiglas to model the water, and a plywood roadbed that will keep the main track level with the module ends.

This approach keeps the module sections lightweight and portable, yet able to perform double duty as both home layout sections and sections that can hook into my modular club's layout at train shows.

The first TOMA section

The contest rules say to focus mainly on the first TOMA section deployment, so that is what I detail here.

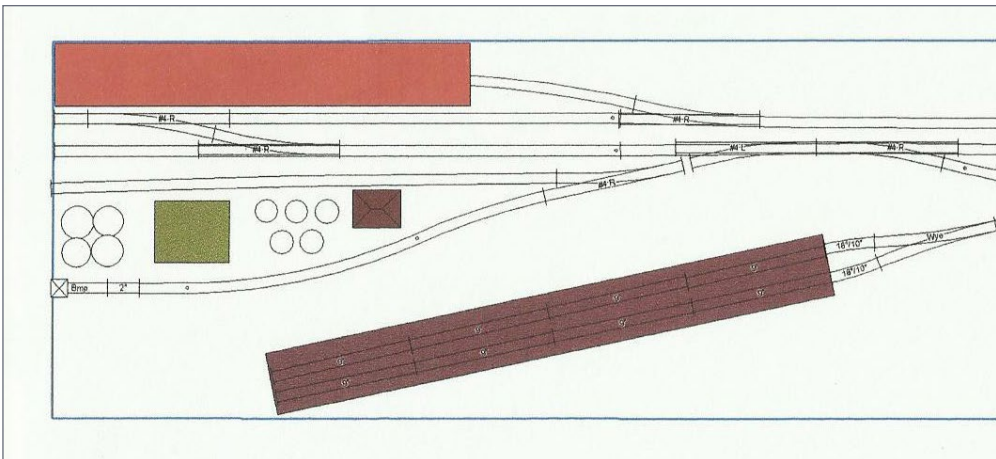

2. My initial TOMA module design.

ONE MODULE CHALLENGE | 4

The first TOMA section full deployment is actually three parts, two 42" left and right 4" dropped-down modules and one 36" filler section for a total size of 10-feet long by 2-feet wide. The Kam Konnect ends allow easy attachment to additional modules, thanks to the locking ends.

I drew this track plan with SCARM. It does not follow a prototype arrangement because there was a lot of selective compression required to fit all the features I wanted to include in the TOMA module section for this contest.

I've included a lumber company warehouse and terminal-sized grain elevator of concrete construction as low-relief background buildings on the back side of the module. The dock sides of these buildings are not modeled due to lack of space. As model rail-roaders, we are more interested in the rail side of these structures anyhow.

In the front, I have cement loading silos and a fuel depot on the left side and a scrap yard and transfer warehouse for general freight

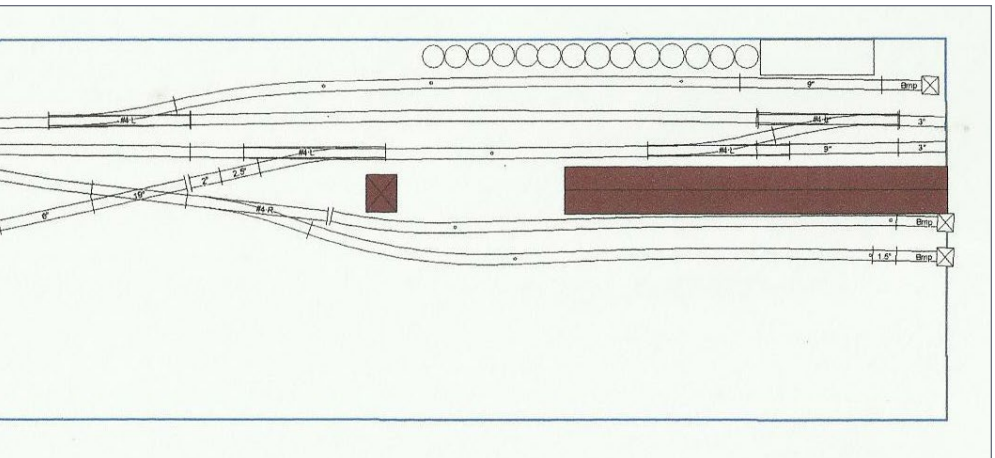

ONE MODULE CHALLENGE | 5

on the right side. Port tracks are not normally parallel to the main track or to the port lead tracks, but are usually perpendicular instead. Due to space constraints and the design considerations, it was necessary to make the tracks more nearly parallel.

I tried to include as many different industries on this first module that actually still exist in Duluth. This adds a more interesting variety of switching movements and different types of freight cars in an operating session.

The car ferry began operation in 1974 and ceased operation in 1992, but I had to include it for more interesting operations, and it adds potential “extra staging” on this module. As to era, this could be any time from the 1920s to modern-day, and it also could be located in any waterfront city in the world, if you so choose.

[3] is the SCARM 3D view of the TOMA module section to show how the buildings would be sized to fit within the available space. It was not possible to show where the land ends and the water begins in Scarm, but this does give a better idea of how the completed module might look. The two tracks angled out into the water are actually on the car ferry.

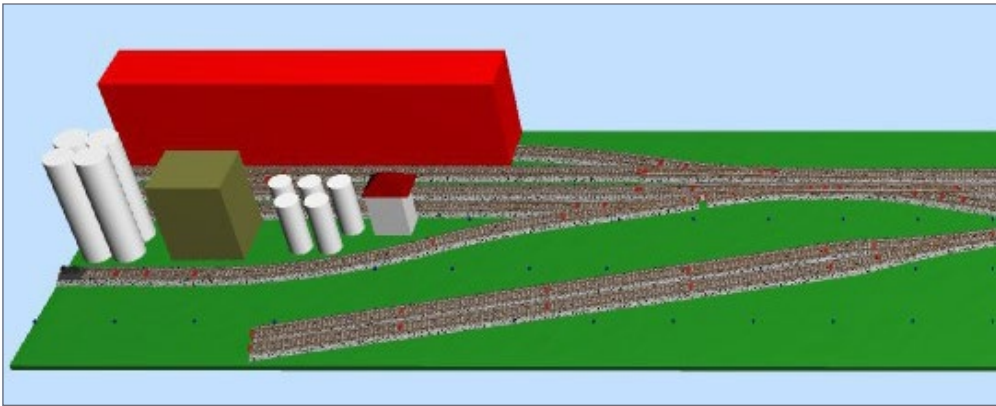

3. SCARM 3D video of the first TOMA module section.

ONE MODULE CHALLENGE | 6

I intend to modify a Walthers' car float with some model ship parts to make it into a motorized car carrier like is shown in the Car Ferry sidebar.

I will need to make my ferry older-looking to fit in with the 1950s era I prefer.

Phased module deployment plan

After I finish the three module sections with their 10-foot-long by 2-foot-wide base, I cut the road bed from ½ inch plywood and attach it to the modules and then begin track laying.

I am using readily available Atlas code 100 sectional track, flex track, and #4 turnouts to keep costs down and speed track laying. I set my required-for-club-use parallel main tracks at 5 and 7 inches from edge of the module and then proceed to lay out the rest of the tracks in the space that is available. I expect to shift the tracks around a bit for the best fit.

Moving on to the Module Construction Progress Plan, in Phase One I have placed the first 10-foot TOMA section in the middle of the 14-foot wall and added two more 2-foot by 2-foot corner

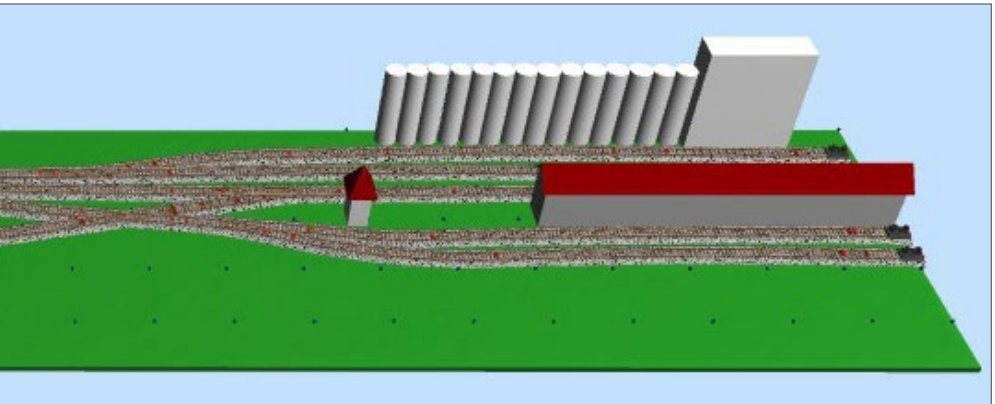

CAR FERRY PHOTOS

Here are some photos of car ferries from the Great Lakes area to serve as an inspiration for kitbashing a ferry to be used on this first TOMA module.



4. (Top) This is the car carrier ferry that operated from Superior, Wisconsin to Thunder Bay, Ontario, Canada, carrying mostly newsprint and other paper in the boxcars. It was named the Incan Superior, and had five tracks on its deck. Even though it ceased operations in the Twin Ports in 1992, it was moved out to Vancouver, BC and is still in operation today between Vancouver and Nanaimo.

5. (Bottom) This ferry has a rather sleek profile as she sails out of the Twin Ports loaded with rail cars.

Start the layout of your dreams now! No space? No problem!

Building a modular home layout with

TOMA

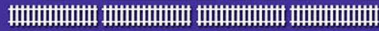

THE ONE MODULE APPROACH

TRAINMASTERS.TV



Building a modular home layout with



Episodes in this video:

- 01. TOMA series introduction
- 02. TOMA design
- 03. TOMA benchwork
- 04. TOMA trackwork
- 05. TOMA wiring
- 06. TOMA structures
- 07. TOMA scenery, part 1
- 08. TOMA scenery, part 2
- 09. TOMA adding details
- 10. TOMA operation

Bonus: TOMA make grass tufts

DVD

PREORDER

\$29.99

~~\$44.99~~



4 disks

Download

Avail. Now!

\$19.99

~~\$29.99~~

DOWNLOAD



11 files

SPECIAL INTRODUCTORY PRICING!

How to build toward that eventual dream pike now in the space you do have!

Brought to you by



Get the video!



• INDEX



SUBSCRIBE (free)

• TABLE OF CONTENTS

ONE MODULE CHALLENGE | 8

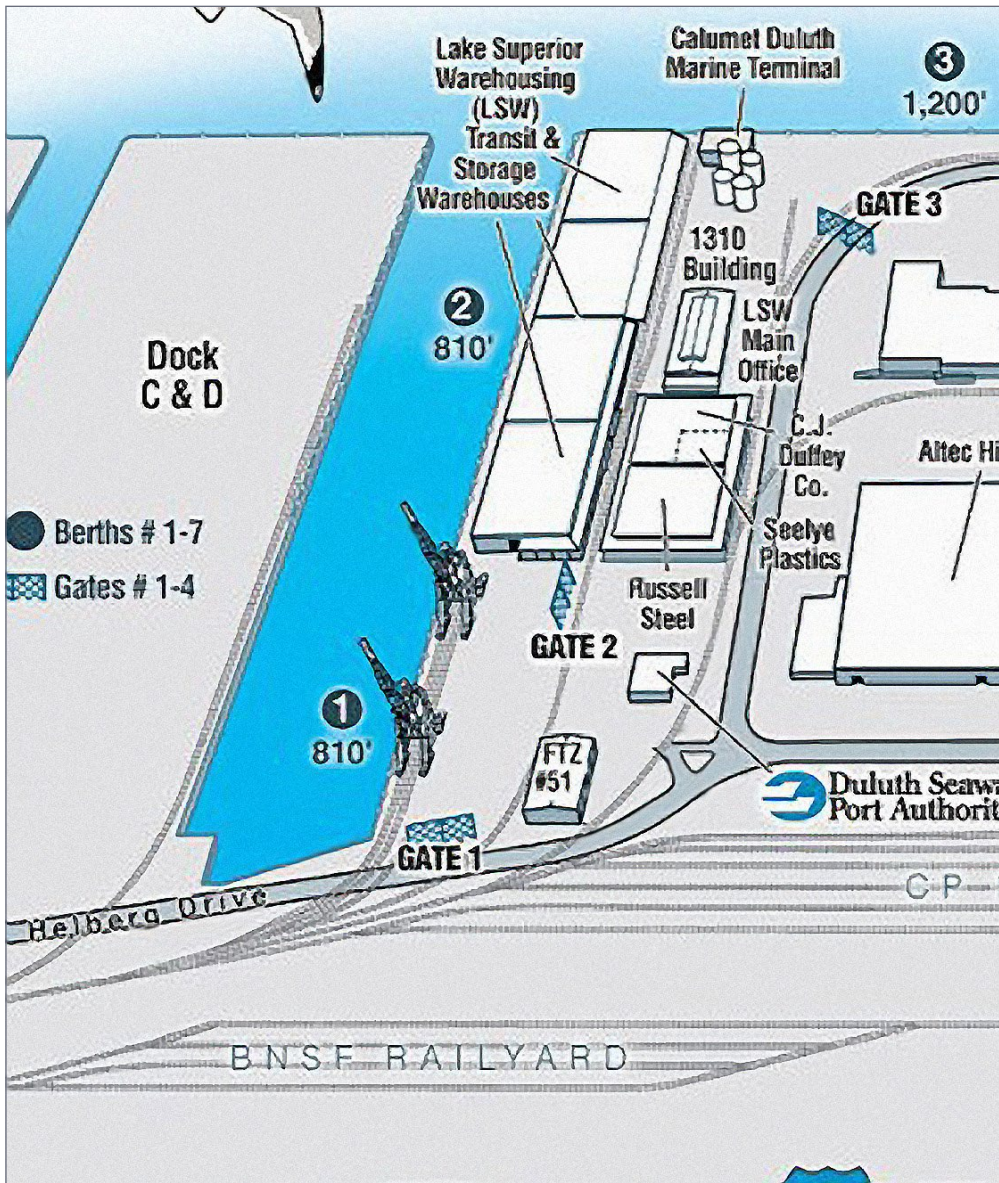

6. This map shows some of the inspiration for my modules. The industries I included are a transfer warehouse, cement silos, and fuel dock on the first module section.

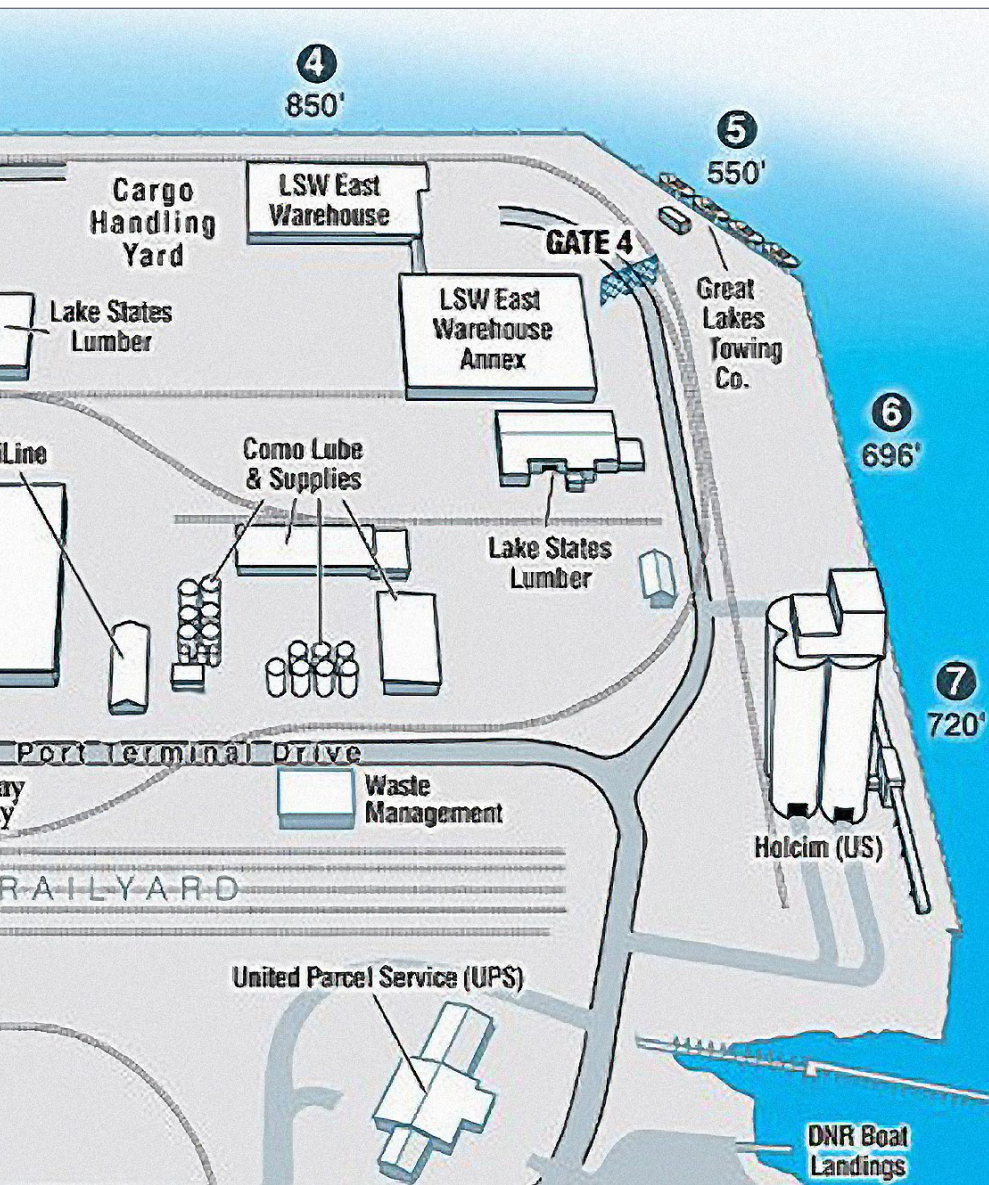



7. A satellite view photo of the Duluth port area in modern times.

ONE MODULE CHALLENGE | 11

adapters. That allows me to attach an 8-inch-wide, 8-foot-long plank for the three-track staging yard on the right side of the room. I then can add two 4-foot by 20-inch wide yard modules on the left side for additional staging and also for building trains. The scale of my drawings are each square equals 4 inches.

In Phase Two I detached the two 20-inch-wide yard modules from the left side and moved them into the closet, by opening one closet door, so no damage is done to the hypothetical room in case it is in a rented home. I add two modules 3 feet long and 2 feet wide with a special 2-foot-square “quad mod” module in between them that allows more modules to be attached on all



8. Here is a large scrap yard that includes some railroad equipment being scrapped and a couple of port terminal grain elevators in the background. Notice the track arrangements and the slips where the ships are docked. One of the Duluth ports in the Rice's Point area has the track wrapped around in such a tight curve that modeling it on a 4-foot by 8-foot table would actually be prototypical in HO scale with an 18-inch radius!



ONE MODULE CHALLENGE | 12

four sides, of which only three sides are available in this plan since the modules are along the wall.

On the first module off the corner there will be a two-stall engine house and servicing area, and any dry land industrial buildings, and warehouses will be on the module next to the closet, along with the railroad yard office.

In Phase Three I add two more special-purpose custom-built modules, and one more 3-foot-long module and one more 2-foot-square quad module to the plan to complete the layout

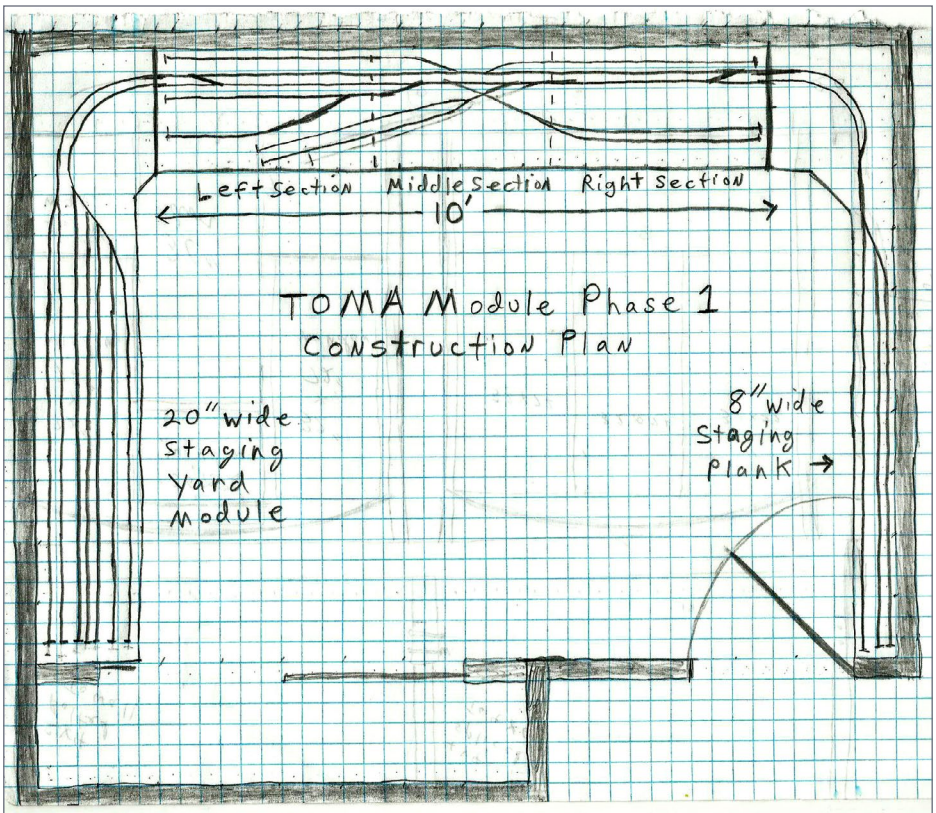

9. Phase One module deployment plan. Each square equals 4 inches in this drawing of the phase one plan.

ONE MODULE CHALLENGE | 13

construction, the first one being a drop-in bridge to connect the main line tracks together to form a continuous run around the room, but allow easy removal to access the inside of the layout area. It fits into the alignment dowels on each module end, and locks into place with perfect alignment of the tracks.

The most exciting part of phase three for me is the 7-foot-long dual-level special dropdown module section that provides space for two Walther's iron ore dock kits, and the Sylvan ore boat with two hull extensions from Walthers. The continuous-run

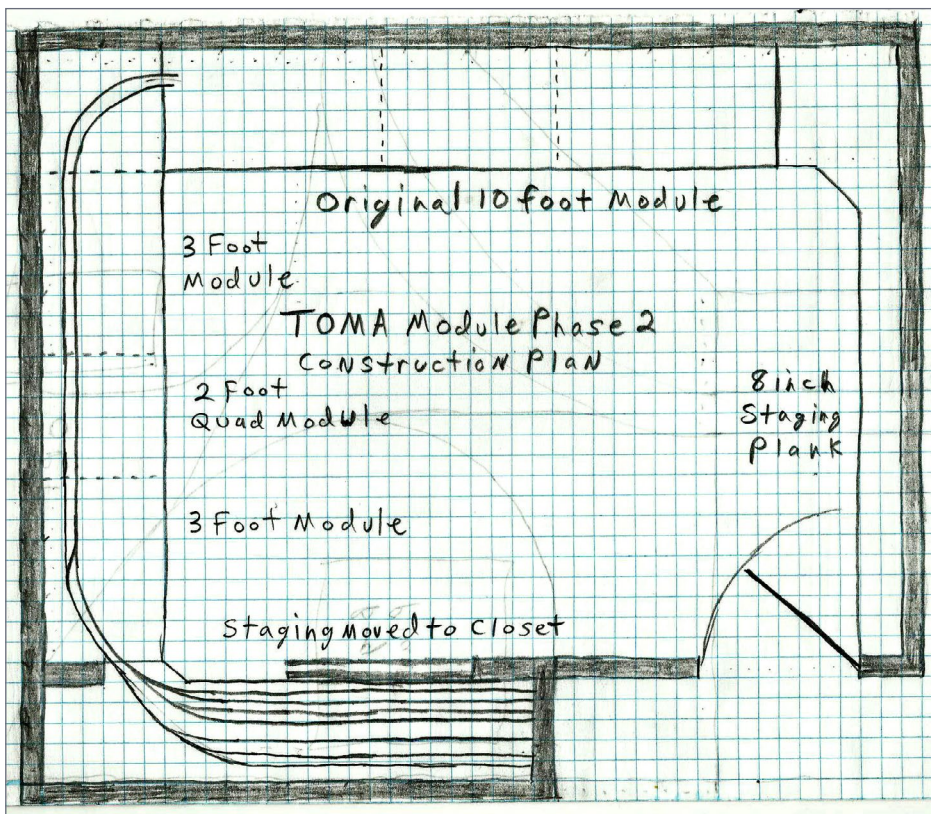

10. Phase Two plan showing the staging yard section moved to the closet, and three additional modules added to the left side of the room.

ONE MODULE CHALLENGE | 14

connection runs behind the backdrop separating the ore dock level from the main line level.

The approach to the ore dock on the prototype railroads would be on a fairly steep grade, and even above other tracks or streets and highways, but lacking the space in this plan the ore dock is sunk 10 inches to allow the approach at level grade. However, it will still be a very dramatic feature and will stand out on this layout.

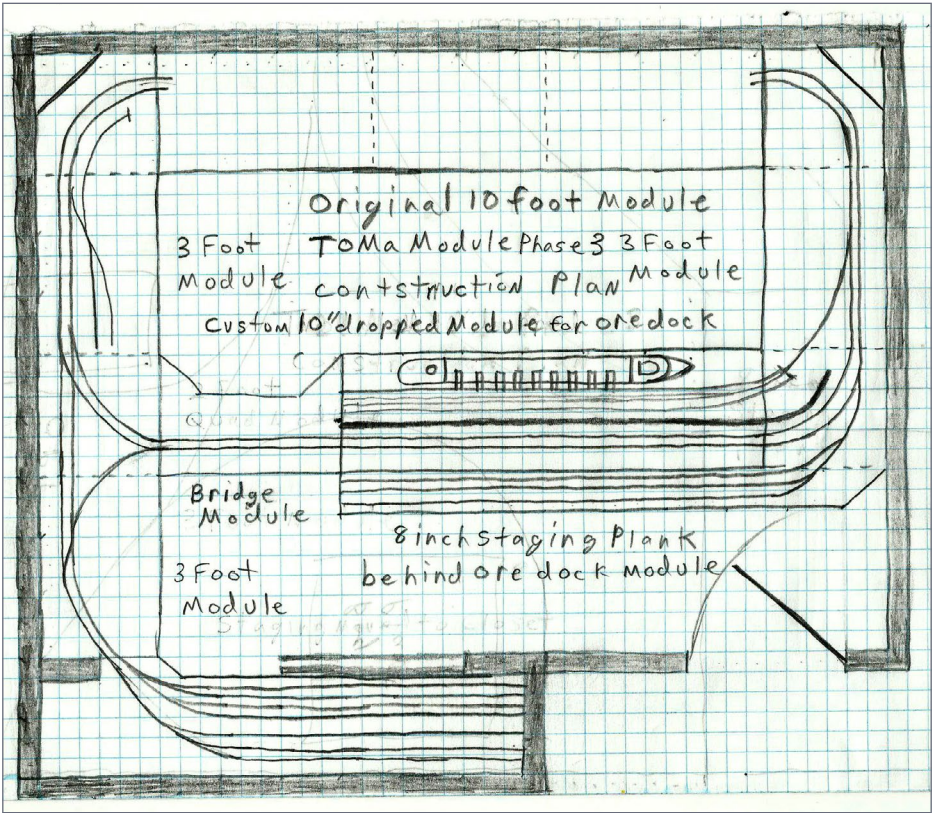

11. Phase Three module deployment plan.

ONE MODULE CHALLENGE | 15

The 8-inch-wide staging plank is moved behind the ore dock module, and is now used for staging iron ore trains as well as regular freight trains. There is still 28 inches of aisle space between the layout and door wall, allowing the door to open, and access to both the staging plank and the main yard inside the closet.

There is a 3-foot-by-10-foot aisle space in the main layout area, allowing room for at least two operators, while a third operator would be in the yard and staging area.

MATERIALS – MODULE 1

The contest specifies only doing the detail work on the first module, so that is all this list includes.

Kam Konnect left and right side purchased modules, \$149.00 each.
Total \$298.00.

Middle section built by me to Kam Konnect specifications:

- ¾" birch plywood panel, 2'x4', \$13.76 at Lowes.
- ¼" hardboard panel, 3'x4', \$5.00 at Home Surplus Warehouse
- ½" high-density foam, 4'x8', \$11.89 at Lowes.
- Kam Konnect milled ends, \$50.00.

Total cost for middle section, \$80.65.

Grand total for benchwork, \$378.65.

Track laying materials:

- ½" birch plywood panel, 2'x4', \$ 16.27 at Lowes. I cut this into strips as a roadbed base.
- One case of cork roadbed, 25 pieces, \$33.95 on eBay.
- Wiring 3 packages of
- Hopkins 2-prong trailer plug connectors with one male end and one female end,



MATERIALS – MODULE 1 CONTINUED...

- \$2.99 each at O'Reily's auto parts, one for each module section.
- (Our club connects these to all our modules, and the wiring bus hooks up to these connectors.)

Other wiring:

- 14-gauge red wire and black wire, one roll each, \$6.99 per roll at O'Reilly Auto Parts.
- Suitcase connectors, bag of 100, \$8.69 on eBay

Grand total for roadbed and wiring, \$72.89.

Track:

All listed is nickel silver code 100 from Atlas, all prices are best deals on eBay, and include shipping cost, because I don't have a hobby shop within reasonable driving distance.

- 1 x wye turnout \$14.29
- 6 x #4 right turnouts \$12.39 each, total \$ 74.34
- 5 x #4 left turnouts \$12.39 each, total \$61.95
- 10 x 9" straight track in package, total \$14.21
- 12 pieces of 3-foot flex track, \$3.90 each, total \$47.70
- 1 x 19° crossing, total \$8.36
- 1 x 1/3-curves from package, total \$3.50
- 5 x Walthers track bumpers from package, total \$15.98

Total for all track needed for first module, \$240.03

Grand total first module estimated costs, \$691.57 plus control system

DC pack, \$36.95, or add \$149.99 for an NCE Powercab starter set, or Digitrax Zephyr for DCC control.

Structures:

- Lumber warehouse built from DPM modular walls and doors, total cost \$48.95
- Grain elevator scratchbuilt from 1½” PVC pipe, and 0.040” styrene total \$22.76
- Transfer warehouse, Pikestuff truck terminal, two kits \$19.34 each, total \$38.68
- Cement silos scratchbuilt from 2” PVC pipe and styrene sheet, total \$14.56
- Fuel depot by Walthers, \$ 34.89 plus scrap yard office by AM models, \$9.55, total \$44.44
- Car ferry using Walthers car float kit, \$49.90,
- Apron, \$34.90
- Model ship parts, \$28.50
- Misc. scenery cost, paint from “screw-up” shelf, \$10.00, Sculptamold, 3 lbs., \$7.87
- sand and ballast material, \$14.59
- ground foam, \$5.99
- shower door, rough Plexiglas for water, free.

Total for, structures and scenery cost estimate \$321.14

Grand total module cost with everything included, benchwork, track, DCC starter set, wiring, structures and scenery, \$1,162.70.



[Click here to rate or comment on this article](#)



Switching the Twin Ports TOMA

For operations on this first TOMA section, the local train arrives from staging on the lower main track with a full load of freight cars for every dock track. Our old-head conductor today is Larry Jones, a rather cranky old guy with about 35 years of railroad experience. The brakeman is Joe Carter, a comical fellow with one lazy eye that has earned him the nickname Cockeyed Joe – he has 16 years railroad experience.

The engineer is me, Jim Moe, but everyone just calls me “Moe.” I have 25 years railroad experience on two different railroads, the Soo Line and the Union Pacific.

We are using an old GP38-2 locomotive from EMD that has seen better days, and is a little rough around the edges. I will have to use some old-school operating tricks to get all our work done today.

We also have a caboose, although these days its main purpose is as a shoving platform.

Old Larry properly blocked our train back at the yard for easier set outs and switching. He walks up from the caboose and cuts

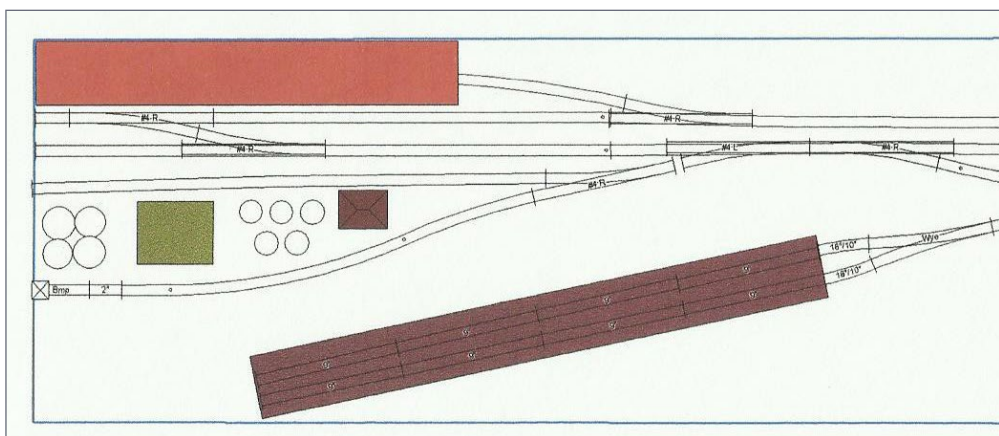

12. The Twin Ports module used in this switching job.

ONE MODULE CHALLENGE | 20

We pull the newsprint-loaded boxcars off the ferry in cuts of three cars each and switch the empty boxcars back onto the ferry. We need to keep the weight balanced so the ferry won't twist the float bridge due to an unevenly loaded deck.

This weight-balanced requirement makes double the work for us since it takes six moves instead of just three to pull and spot the car ferry. By using the grain hoppers, lumber rack cars, and gondola cars of scrap between the locomotive and boxcars on the ferry, our balancing act works out perfectly.

With the switching of the car ferry completed, we couple-up to the train and pull everything clear of the switch leading to the scrap yard and transfer warehouse. We come off with the lumber rack cars attached, then shove through the crossover switches.

We work Duluth Timber, with the set out cars being spotted up for loading at the warehouse. We shove the pulled cars clear of the crossover switches. We now just have the light engine and we couple-up to the rear of the train. With half of our work completed, it's time to take a lunch break.

After lunch, it's time to switch-out the scrap yard and dock side transfer warehouse. We find this a lot easier since we have an empty track on the dock side where we can shove the setout cars before pulling the outbound cars off spot. The boxcar doors have to be lined up with the warehouse doors, but the loaded scrap gondola cars spot isn't so fussy, since workers use backhoes with magnets to unload the scrap.

With the scrap yard and warehouse work done, it's time to work the grain elevator by using the crossover switches to shove the grain cars up beside the grain elevator.

We uncouple the locomotive and run it light back to the crossover switches by Duluth Timber. We reach the grain elevator

ONE MODULE CHALLENGE | 21

switch and pull the empties, which we hold onto while spotting the loads over the dump pits.

We shove the empties clear of the crossover and again run light to the timber crossovers and retrieve our train. We shove the train back through the crossovers by the elevator, pick up the empties and then pull the entire train clear of the crossovers.

Next, we pick up the lumber rack cars and shove them back through the crossovers to put them on the rear of the train.

We cut off the caboose from the locomotive, finish the run-around move, then couple the train onto the caboose.

We are done with our work at the port and depart for the yard. It's been a long hard day and we are happy to be done.

Several scenarios like this are possible. Not every spot or industry would need to be switched on the same trip.

I wrote this in story form because of my real world experience switching industries. Plus I want to show how much activity is possible on just this one TOMA module.

I feel this TOMA module can give many hours of enjoyment switching the twin ports job.

Please tell your buddies about MRH!

WE RELY ON WORD-OF-MOUTH TO GROW AND A BIGGER CIRCULATION MEANS MRH IS MORE LIKELY TO STICK AROUND FOR A LONG TIME TO COME!



PROTOTYPE INSPIRATION FOR MY LAYOUT DESIGN

The twin ports of Duluth/Superior were once served by nine different railroads, but after all of the mergers, only four remain today.

The nine railroads listed in alphabetical order include the Chicago, St Paul, Minneapolis & Omaha, the Duluth & Iron Range, the Duluth Missabe & Northern, the Duluth South Shore & Atlantic, the Duluth Winnipeg & Pacific, the Great Northern, the Lake Superior Terminal & Transfer, the Northern Pacific, and my favorite, the Soo Line railroad.

The four railroads that remain include BNSF, Canadian Pacific, Canadian National, and my current employer, Union Pacific.





13-14. (Bottom left, top right) These two pictures are early historical photographs showing part of the port area in Duluth.

15. (Bottom) Great Northern iron ore docks in the Twin Ports area. Most of them were over 2,000 feet long.

THE KAM KONNECT SYSTEM

I assemble most of the modules myself after I have the parts cut with Kam Konnect's CNC machine. It is possible to purchase just the ends with the male and female locking connectors using alignment holes and dowels installed for custom built modules.

When I am at work as an engineer on the Union Pacific Railroad operating 1:1 locomotives, I am sitting down. That is also the way I prefer to operate model railroads.

I have set my module height at 36" using Kam Konnect's optional folding leg system, allowing sit-down operations using a rolling office chair. The modules could be easily mounted on shelf brackets and attached to the walls for those who prefer eye-level standing operations.

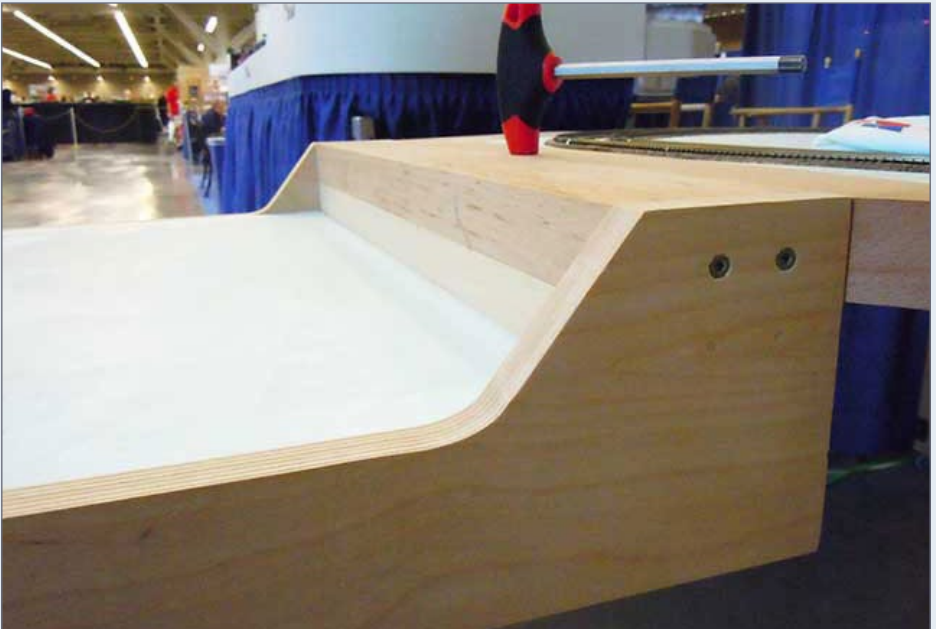

ONE MODULE CHALLENGE | 25



16. (Left bottom) This photograph from Kam Konnect shows how a drop-down module is built with 18mm Baltic Birch (13 plies thick, total 3/4") plywood sides and ends. The base is 1/4" hardboard with 1/2" foam board for scenery. I will add 12mm (1/2") cabinet-grade plywood for the track roadbed.

17. (Above) These pictures are from Kam Konnect's website, and show the legs folded down, folded up, and a closeup view of the leg hinge and locking mechanism. Levelers are included in the legs.



JIM MOE

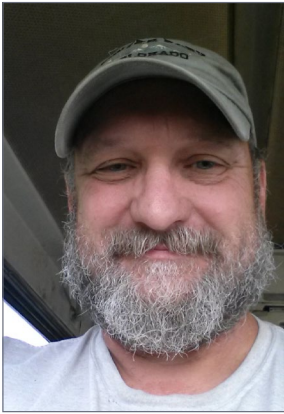

Jim has worked as an auto body technician in the past, and as a locomotive engineer for the last 25 years. He worked on the Soo Line/Canadian Pacific railroad from 1992-97 in Northern MN, and on Union Pacific from 1997-present day in Southeast Texas.

He grew up on a farm near Thief River Falls, MN by the Soo Line tracks. His interest in full size steam locomotives began with the Freedom Train in 1976, and the visiting Canadian Pacific Royal Hudson steam train

in 1979. He has actually operated a former Soo Line Alco 0-6-0 steam switch engine #353 from 1988 to 1994 in central MN. He assisted in the relocation of Soo #1024, a former Monon Mikado, and has visited the Union Pacific Steam shops in Cheyenne, WY.

Jim started HO scale model railroading with a Tyco steam train set at age 6, and it grew to a 12 X 24 foot layout in just five years. He currently models the Soo Line railroad in HO scale, on modules set in 1954, and a freelance railroad, Minneapolis, Omaha, Eastern, (MOE Line) that interchanges with both the Soo and UP.

Jim is an active member of the NMRA and the Southeast Texas Model Railroad Club, a modular club that travels and displays at train shows throughout Texas.

Jim and wife SuzAnne, reside in Vidor, TX. He has four stepchildren, and over a dozen grandchildren, including granddaughter Te'a, who enjoys the model railroad shows. His other hobbies include home improvement projects and customizing hot rods, trucks, and sport cars.



[Click here to rate or comment on this article](#)

NEW!

Airbrushing how-to videos!

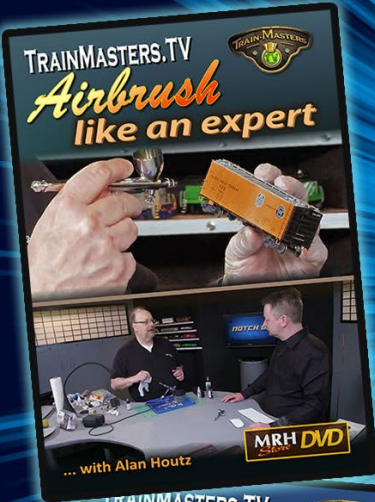

Order Videos! 

Airbrush like an expert

- Airbrushing 101 - All about airbrushes
- Airbrushing 102 - Outfitting and strip-down
- Airbrushing 103 - Painting technique
- Airbrushing 104 - Simple weathering
- Bonus: Easy airbrush cleaning

Video download: \$16.49

DVD Preorder: \$24.99

Weathering steam locos with an airbrush

- Into & weathering working passenger steam
- Weathering working freight steam
- Weathering steam near end-of-service

Video download: \$12.49

DVD Preorder: \$19.99

SPECIAL VIDEO PRICING!



from the
**Model Railroad
Hobbyist Store**

• INDEX



SUBSCRIBE
(free)

• TABLE OF CONTENTS

PRINTED CIRCUIT BOARDS

for Model Railroaders



BY MARK UNDERWOOD

This new breed of engineering software replaces etching your own boards ...

RECENT CHANGES IN THE MARKET FOR HOBBY/enthusiast electronics have made modern printed circuit boards (“PCBs”) an affordable option for homemade model railroad electronics. Modern Electronic Design Automation (“EDA”) software

• [INDEX](#)

• [TABLE OF CONTENTS](#)



[Click here to rate or comment on this article](#)

and prototype PCB services make it easy for the hobbyist to produce a professional-quality board at low cost, and in any quantity needed.

Commercially manufactured PCBs have several benefits over home-etched boards or hand-assembled perf-boards:

- More reliable operation
- Neater appearance
- Easier assembly
- Easier to use with modern surface-mount (SMT) components
- No chemicals
- Smaller size
- Silk screened labeling
- Easier to make, share, or even sell multiple copies of the design

PCBs are designed using Electronic Design Automation software. Many easy- to-use EDA packages are now available that are either free or affordable to the hobbyist. Most EDA packages follow the same basic workflow:

1. Design (“capture”) the circuit schematic
2. Assign “footprints” to each component in the design
3. Place the component footprints on the PCB outline
4. Route the wire “traces” between the component pads or pins
5. Perform a Design Rule Check (DRC) and create the silkscreen text
6. Send the completed design to a PCB manufacturer (“fabricator” or “fab”) for manufacturing
7. Assemble and test the completed circuit board



PARTS KEY

Refdes*	Description
R1, R4, R7, R8	10K resistor
R2	100K resistor
R3	500K trim pot
R5, R6	820Ω resistor
C1	2.2uF Polarized capacitor, SMT
LED1, LED2	Red LED
U1	LM556 Timer
Q1	P-FET Transistor
J1	5-pin screw terminal

2. Available boards, along with advice, are found at circuitous.ca/CircuitIndex.html.

*Reference designator



PRINTED CIRCUIT BOARDS | 5

This process has many similarities to model railroad layout design, and while at first it may seem intimidating, an interested model railroader can quickly add this skill to his tool set.

Design the circuit and assign footprints

The first step is to design the circuit, and “capture” it in the schematic drawing program. There are many places to find circuit designs, including books, magazines, and websites, or you can design your own. Our example circuit is a simple grade crossing flasher circuit, adapted from a design by Rob Paisley and posted on his “Model Railroad and Misc Electronics” (circuitous.ca/CircuitIndex.html) website. I selected this circuit

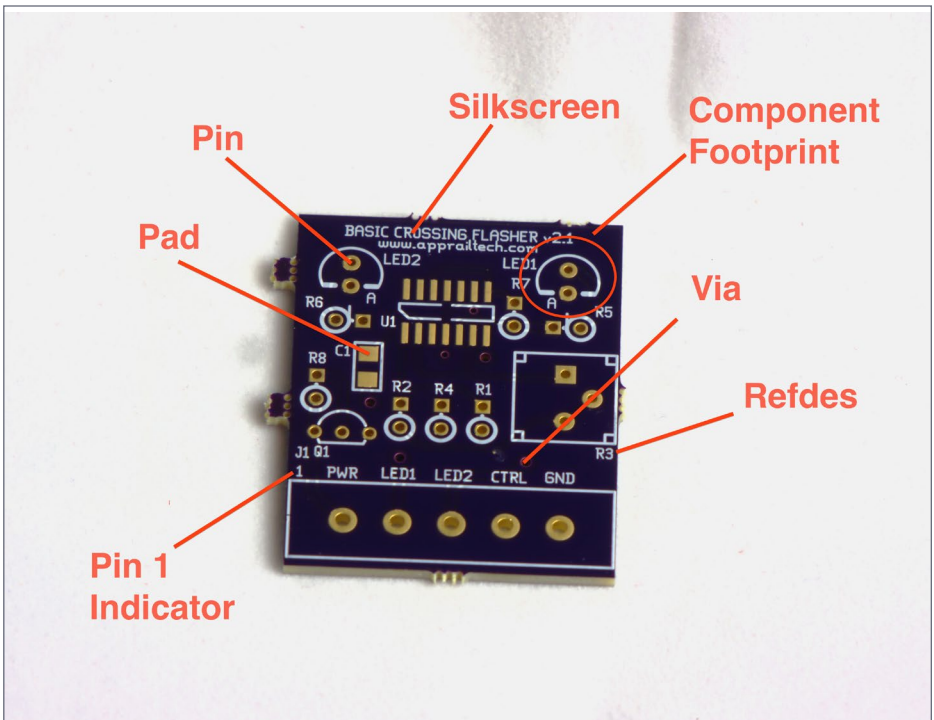

3. This is the completed example circuit board, with examples of the different parts identified.

Did you know there's an MRH index available?

CLICK TO FIND OUT MORE

because it is simple but useful, and includes several different component types, to help illustrate the PCB design process.

Because the focus of this article is on the PCB design and construction, not the circuit design, I will not describe the function of the circuit. If you are interested, a thorough explanation is provided on Rob Paisley's site.

Once I've drawn the circuit in the schematic program, I choose which physical package (form) each component should have, and assign a corresponding "footprint" to the component symbol in the schematic. A footprint is the physical hole or pin pattern for a component. Footprints are usually stored in "libraries" that organize them by function, size, etc.

The choice of package is driven by many design considerations. What packages are available? Should the component be surface-mount or through-hole? How large does it need to be? For connectors, how do I want the user to attach wires? Should they be oriented



straight up or at an angle? For user-interface items (switches, buttons, LEDs, displays), how should they be oriented? What sort of interaction will I have? What about cost and parts availability?

For this circuit, I selected screw terminals for the wires, surface-mount packages for the timer chip and capacitor (to demonstrate surface-mount PCB design), and through-hole components for easy hand assembly of the other components. I then consulted the various electronics suppliers to select specific parts that will be used.

Once the parts have been selected, I find matching footprints for each part and assign these footprints to the component symbols in the schematic drawing. The footprint describes how the component is attached to the PCB – pin hole or pad locations and sizes, mounting holes or features, overall size, and markings to indicate “pin 1” or positive vs. negative terminal, for example. Usually I can find something suitable in my software’s built-in footprint library, but sometimes I must go online, or even create my own footprint from the part vendor’s specification drawings.

It is crucial to make certain that the selected footprint is a good match for the intended component. Components are usually made in standardized packages, but there can still be differences that will break a design. In particular, double- and triple-check the following on the footprints you choose:

- Pin or pad name assignments – make sure these match the actual device and the schematic symbol!
- Pin hole diameters with clearance
- Pin or pad locations and shapes
- Overall size and clearance around the device

The next step is to convert the symbolic schematic diagram into the physical PCB layout. Exactly how this is done varies from

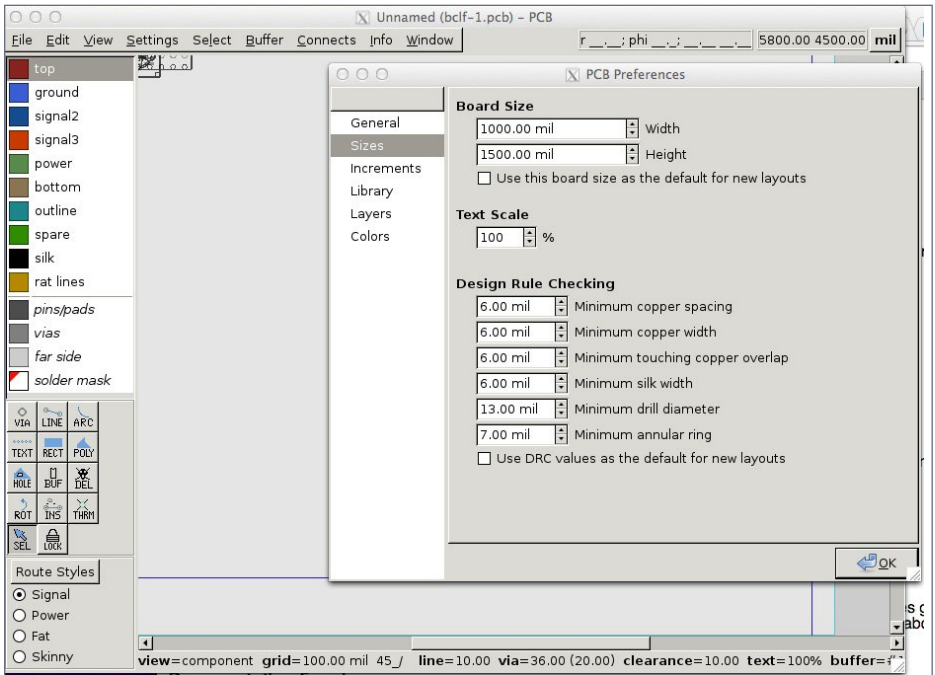

4. Setting preferences in the PCB design program. I choose the overall board size and the layers I will use. Then I set the design rules to match the requirements of my selected PCB vendor.

software application to application. The software I use has a separate program to do the conversion, but other applications may have a menu selection or may do the conversion automatically.

Set PCB layout preferences

Before drawing the PCB design, I set the design preferences. I choose the overall height and width of the board, choose how many layers the board will have, and set the design rules for the PCB vendor (manufacturer) I plan to work with. Design rules describe the particular limitations the vendor places on the design to match their manufacturing process. Examples include

minimum trace width and separation, allowable drill hole sizes, and required clearances between holes and board edges.

A PCB can have many layers of circuits, but most common circuits for model railroad use can be easily designed with just two circuit layers – the top and bottom of the board. There are also separate layers for the top and bottom solder mask (a protective coating over the copper traces that has openings where solder will be applied during assembly) and for the silk-screened labeling on the board. Most PCB design programs will automatically manage the solder mask layer, but in some cases I modify the mask design by hand. For example, I might need to expose an area of metal to help dissipate heat around a component. At this point I also delete any of the default layers that I will not need for this design.

I often start with the overall board size set to an inch or two longer and wider than the final dimensions. This allows some working room to move components around during the next step. I then adjust the dimensions to their final value once the design is nearly complete.

Place the components

Now it is time to arrange the components on the board. To do this properly, I consider how the board will be used, and balance board size and shape against cost and usability. I determine where wires should enter or exit the board, how the board will be mounted to the layout or control panel, and how any user interface components should be arranged to be logical and easy to use. The height of components can also be a factor in their placement, and can affect how the board is mounted or connected to other parts of the layout.

I also consider the flow of the wiring, and try to arrange the components so that the copper traces, or connections, will be

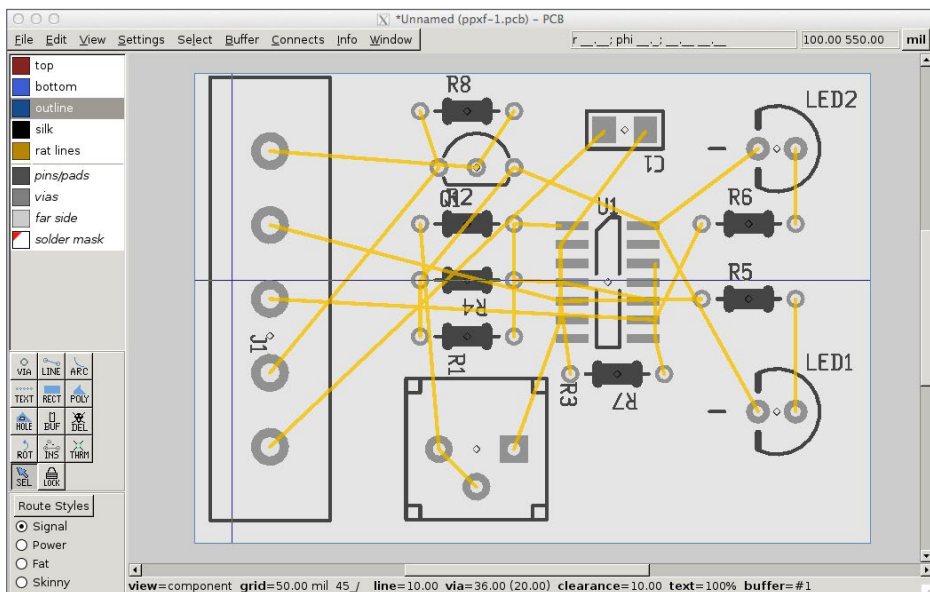

5. I've placed the screw terminals and flash adjustment at the left and the LEDs at the right side of the board. The yellow lines are "ratlines" that represent wiring connections that I have not yet routed (drawn) on the board.

as short and easy to arrange as practical. This is also the time to make special consideration for cooling space or heat sinks for components that will get hot, extra clearance for wide traces for high-current circuits, and space for any other special circuitry. Finally, I make sure when arranging connectors and user interface components to leave space for labeling and for large fingers and older eyes.

Component placement is an iterative process, so I don't expect to get the placement perfect on the first try. I often make several repetitive passes at the design, refining it as I go until I have found a satisfactory result. I may need to move components around as the wiring is done, and even go all the way back to the schematic to reassign pins or redesign part of the circuit to

PRINTED CIRCUIT BOARDS | 11

make the PCB layout work. This is actually quite similar to the track-planning process, where the designer must adjust the track plan to fit the space and other requirements or limitations as he refines the layout design.

Route the signal traces

Once I have placed the components, it is time to start drawing the circuits. The set of connections between pins of all the components is called the *netlist*, and the individual connections are often referred to as *nets*. The PCB design software usually shows these connections as a “rat’s nest” of straight lines at first, removing the lines as each net is *routed* (drawn) on the PCB. In fact, the straight lines representing unrouted connections are sometimes referred to as “ratlines” in the software.

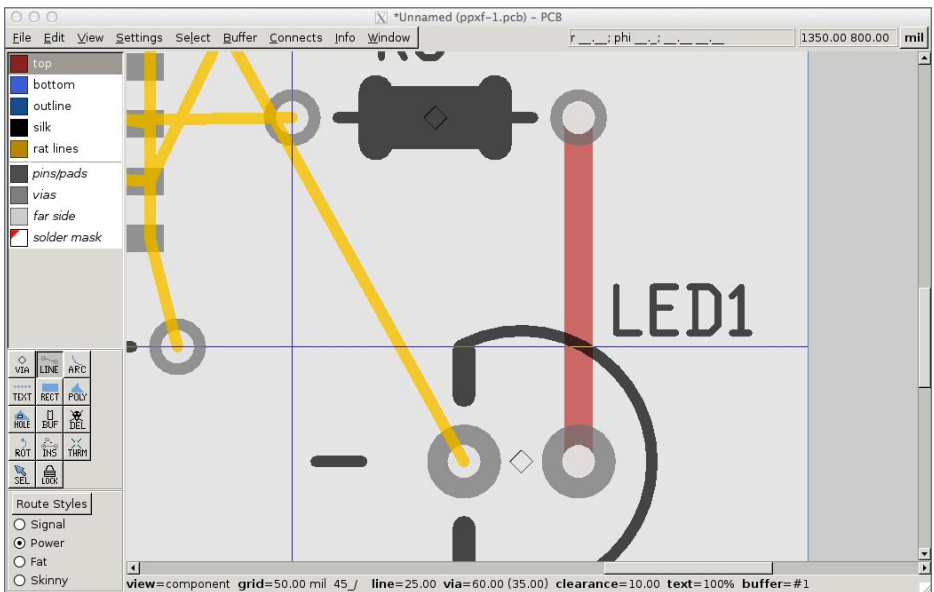

6. Yellow “ratlines” show wiring connections that have not yet been “routed” or drawn on the board. The red line is a “trace” (connection) that has been routed on the top copper layer.

PRINTED CIRCUIT BOARDS | 12

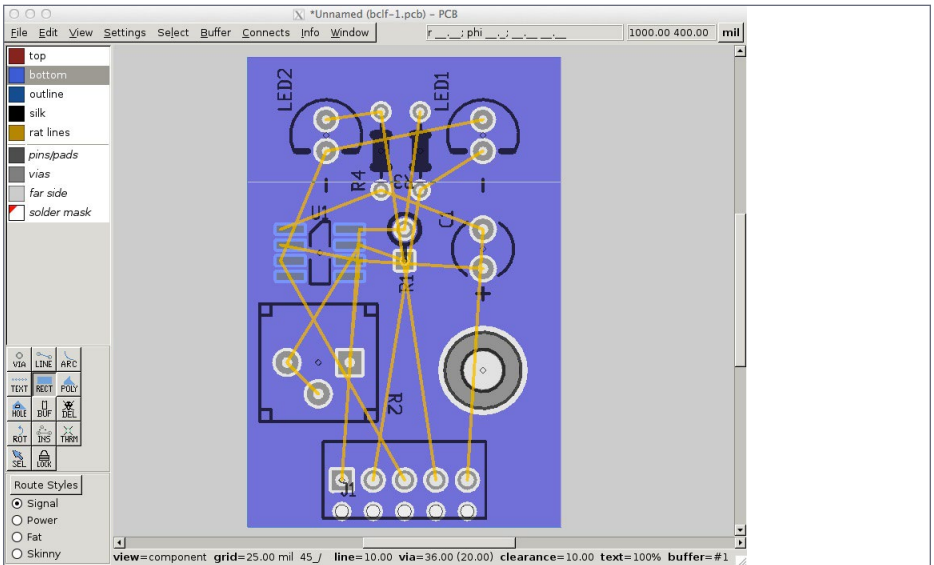
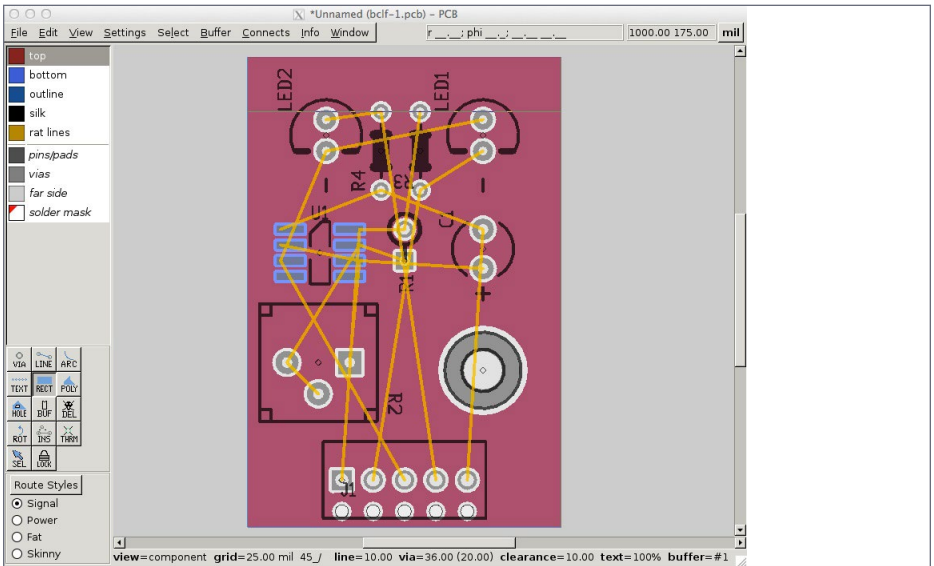

7. I cover the top (red) and bottom (blue) of the board with copper planes (board rotated vertical here). When I later draw traces, they will be carved out of the planes, leaving as much of the board as possible covered in copper.



The screen shows each layer in a different color, and I can turn layers on or off to see each layer separately or different layers together, much like layers in a track planning program. The top copper layer (front side of the board) here is in red, while the bottom copper layer (back side) is in blue. Silkscreen printing is shown in black. Pads, pins, and other metal areas are shown in silver, while holes and other open areas are in the white (or grey) background color. On the copper layers, the color represents where the copper will be present, and blank space (background color) represents where copper will be removed from the board.

The layers are shown semi-transparently, so that lower layers are visible through the upper. This allows me to see both the top and bottom side layers at the same time. For example if I have the view set to the top side, blue areas show where copper will be on the bottom side, and purple areas show where copper will be on both top and bottom of the board.

I use the line tool to draw each trace, connecting all the pins or pads for that net. At times, I need to pass the trace from one side to the other. To do this, I place a *via*, which is a hole drilled through the board and filled with solder when the board is made. This acts as a vertical “wire” connecting the traces at top and bottom of the board. A component pin can also serve as a via, as shown on the pin of R3 in [9].

Power and Ground signals are among the most important nets on the board, so I usually start with these. These signals need to be as large and as short as practical to keep the wire resistance down and avoid problems with circuit operation. One technique to make this easier is to use *planes* for power and ground. A plane is a large area of copper, rather than a narrow, wire-like trace. I cover the entire top and bottom of the board with copper, then connect all power pins to the top plane and ground pins to the bottom plane. Then I carve the rest of the circuit nets out of

these planes, leaving the entire unused part of the board as the power and ground “traces.”

I connect pads and pins to planes through “thermals,” which are short, narrow traces from the pin to the plane. If a pad or pin is connected directly to a power or ground plane, it can be very difficult to solder successfully. The large amount of copper in the plane acts as a *heat sink*, which draws heat away from the solder point and prevents it from heating up quickly enough. The thermals are short enough that they do not affect the electrical resistance of the connection, but small enough that they allow the pin to heat up quickly during soldering without losing the heat to the plane. The PCB drawing software has a “thermal tool” that automatically draws the narrow traces with a single click.

In [8], the short red (top side) traces connecting the topmost pin on U1 to the large red area, and the short blue (bottom side) traces connecting the via to the back side are thermals.

Next, I route any “key” circuits in the design. These are nets that carry high speed or high power signals, or are otherwise critical to circuit operation. For example, high current nets need to be as large

***TrainMasters TV is part of
the MRH product family.***

*TMTV members not only get great network TV level
videos, they help pay for MRH and keep it free ...*



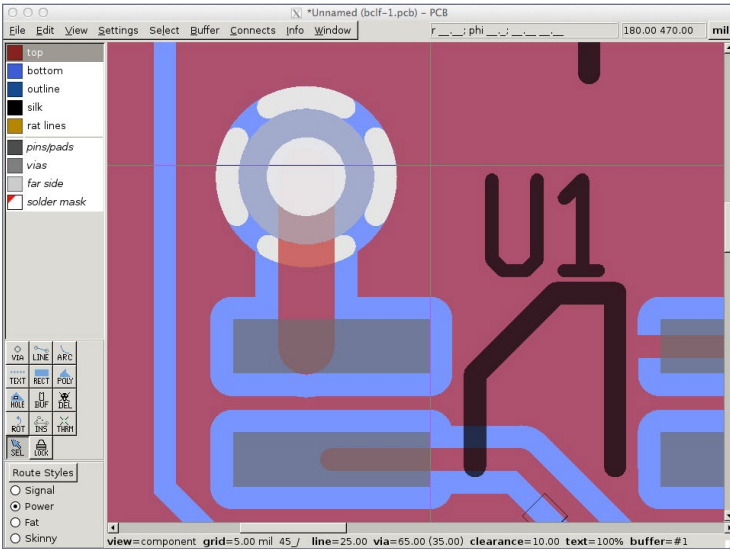
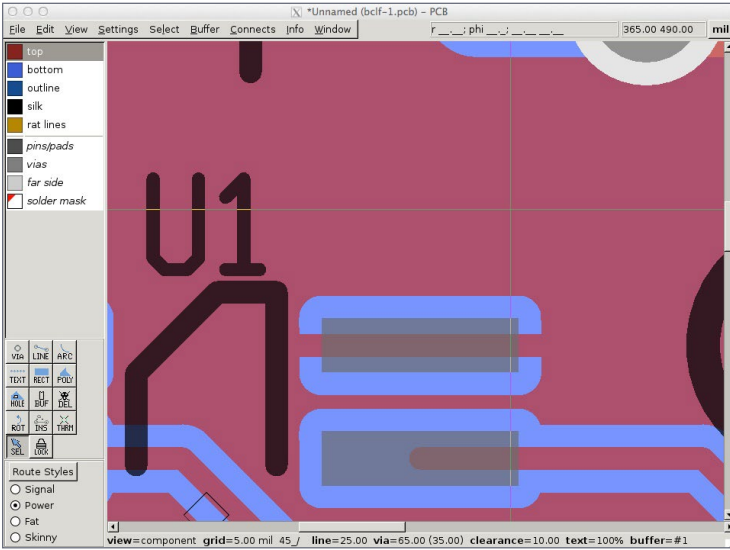

8. Thermals connect a SMT pad (top) and a via (bottom) to the power and ground planes. The board is seen from the top. The blue color shows areas where there is copper on the bottom layer but not on the top layer, and the white area is where there is no copper on either side of the board.

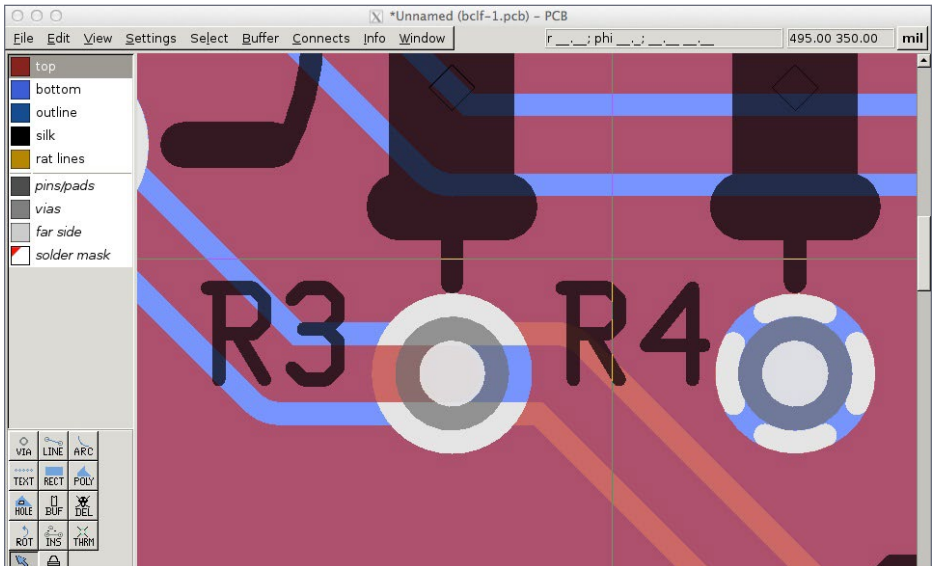

9. The pin on resistor R3 acts as a via for the trace connected to it. The pin on R4 is connected to the ground plane (blue) on the back side of the board with a thermal.

as practical, and high speed nets require careful routing. Once I have routed the key circuits, I finish routing the rest of the nets.

Normally, I enjoy the visual puzzle-solving aspect of routing traces on a PCB. When things get difficult, most PCB design programs have an *autorouter* that will route all of the remaining traces; however, it may not choose the best routes for the signals, so I do not rely upon it for key or critical traces. Again, this process is very similar to the iterative process to design a track plan.

Often, the netlist routing step, like the placement step, is iterative. I often re-route signals to make room for others, move components to make the routing easier, or even go back to the schematic and reassign component pins (where possible) to find a solution.

When all of the wires are routed, there will be no more yellow “rat-lines.” The top and bottom layers of our design look as shown in [10].

PRINTED CIRCUIT BOARDS | 17

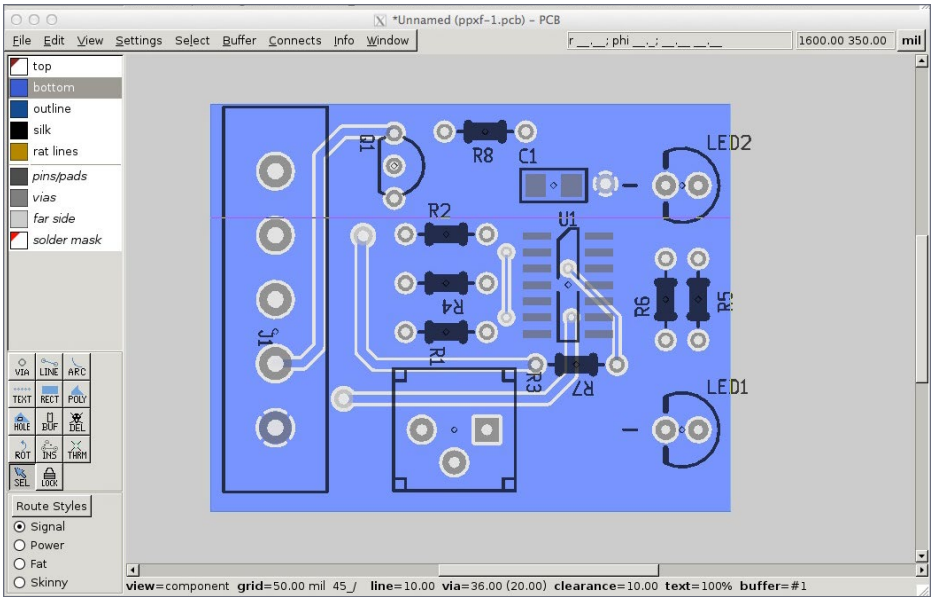
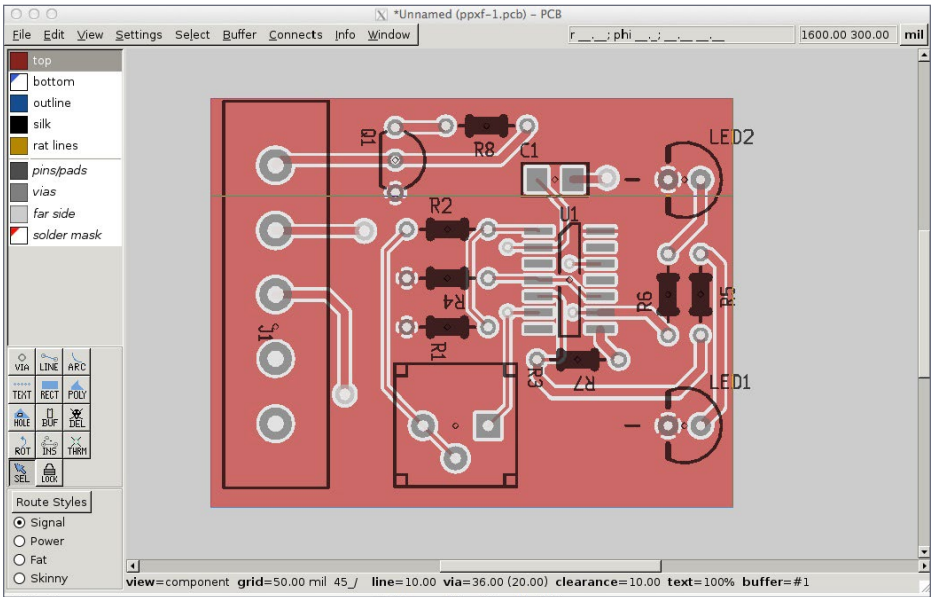

10. The top side (red) and bottom side (blue) traces and planes on the fully routed board.

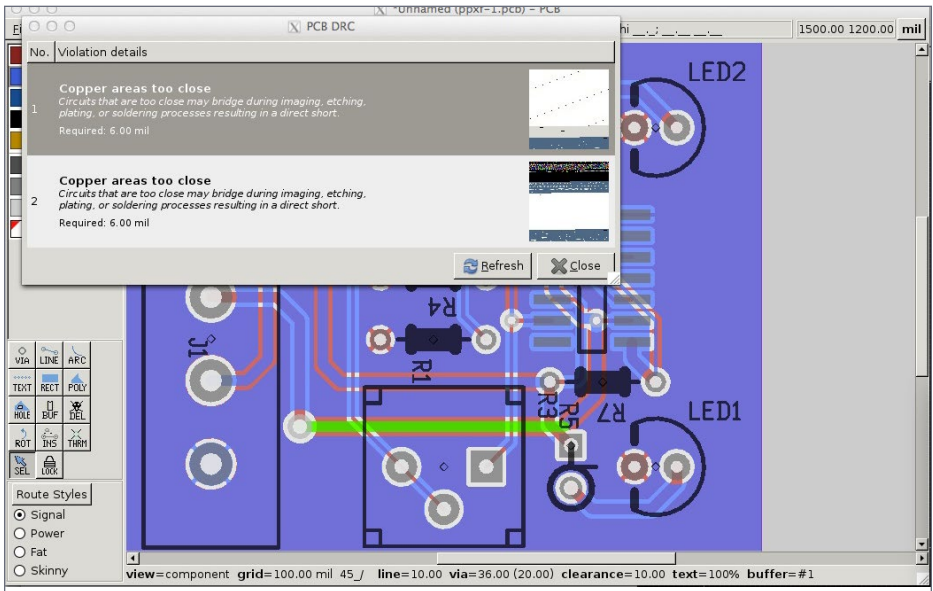

11. The DRC tool highlights a trace that is too close to other traces in bright green. If the trace is not moved, variations in the manufacturing of the board may cause the trace to short to adjacent traces.

Design rule check and silkscreen

Once the components are placed and the traces all routed, the next step is a design rule check (DRC). The PCB design program usually does this on command, checking the whole design against the design rules I set in the preferences, flagging parts of the design that do not meet the vendor's requirements, as shown in [11].

Examples include holes that are the wrong size or traces that are too thin or too close together.

I also carefully review the design myself, checking for things that the DRC tool will not find. Is it neat? Will it be easy to assemble? Have I positioned the connectors and buttons and LEDs where I need them? Are there any mistakes in the

schematic design? Did I set the board size correctly? Do the footprints *really* match the actual components, and do their pin names match the schematic connections?

Once I have corrected all of the DRC errors and I am satisfied with the layout, I clean up the silkscreen layer, where the labels appear.

Each component has an identifier (e.g. R12 for resistor #12), called a reference designator or “refdes” that will aid in assembly. Some components have marks that identify a positive or negative terminal, while connectors and integrated circuits (ICs or “chips”) usually have pin 1 identified. I like to position all of these identifiers so that they will be easy to see even with the components installed, and rotate them so that they are all “right-side-up” when the board is oriented “right-side-up” in my hand. One exception is that I prefer to rotate connector names so that the

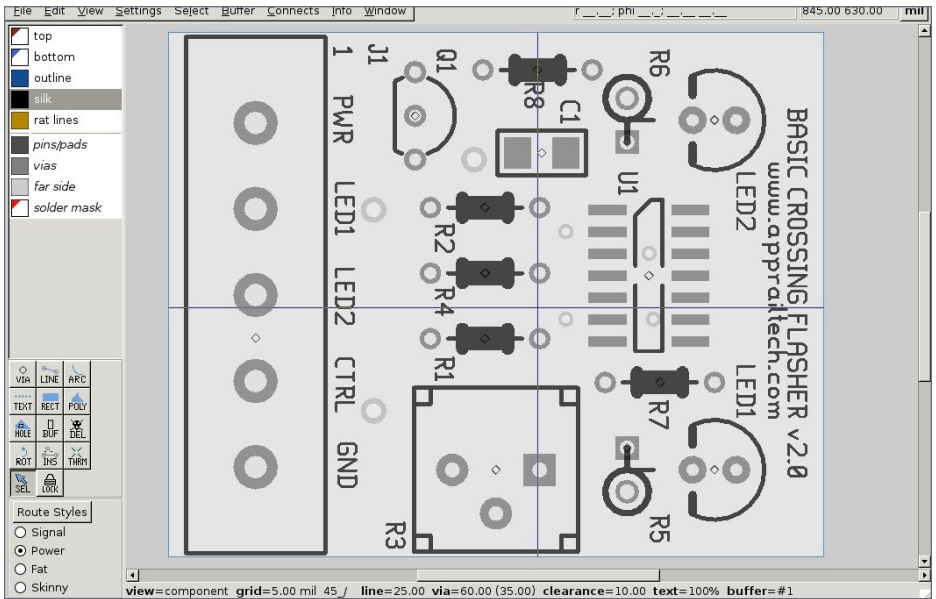

12. Adjust and check the silkscreen printing layer. It is often easier to do this with the other layers turned off or hidden.

lettering faces “out” – right-side-up when the board is held with that connector at the bottom.

I also like to include a name for the board and a version number, to help keep track of changes I make, and I put my website address on it, in case I decide to share or sell it. If there is room, I will also label the connector pins and user interface parts. I consider what I would want to see when trying to install the board or fix something later, and make sure it is included, even if I have to make the board a little bit bigger to fit it all in. PCBs are priced by the square inch, but frustration is priced much higher.

Submitting the design for fabrication

Once I am satisfied with the design, it is time to have some boards made. I package the design files the way my chosen PCB vendor requires. I collect the set of design files generated by the PCB program into a ZIP archive file and submit it to my vendor through their website interface. Most vendors accept design files in the industry-standard “Gerber” file format, with one Gerber file per layer, plus a few extra files to describe the board outline and other details. There is usually one “Excellon” format file for holes that will be drilled and plated with metal (vias and pin holes), and another for holes that will be drilled but not plated (mounting holes).

Before I submit the board, though, I try to “sleep on it” for a day or two. I find that one of the most frustrating parts about this process is that I always seem to think of an improvement or change to make, or a problem that must be addressed, right *after* I have submitted and paid for the design. The boards are inexpensive, so the financial cost of a mistake or change is much lower than it used to be, but it is still an aggravating and time-consuming experience to have to resubmit an order.



The vendor I use most often for hobby projects is OSH Park. Their submission process is very simple: Upload the ZIP file, wait a few minutes for them to check it, verify the layer drawings, and approve the design.

OSH Park is an example of “batch” service companies that combine multiple small designs into a single large standard-sized panel that is easier and less expensive for a PCB manufacturer to build. They then send the combined *panel* of circuits to a high volume board fabricator, divide up the completed panel, and ship the individual boards out to customers like me. By combining many small designs into one large board, they are able to keep costs low and share the cost of manufacturing the boards among many individual customers. For example, my crossing

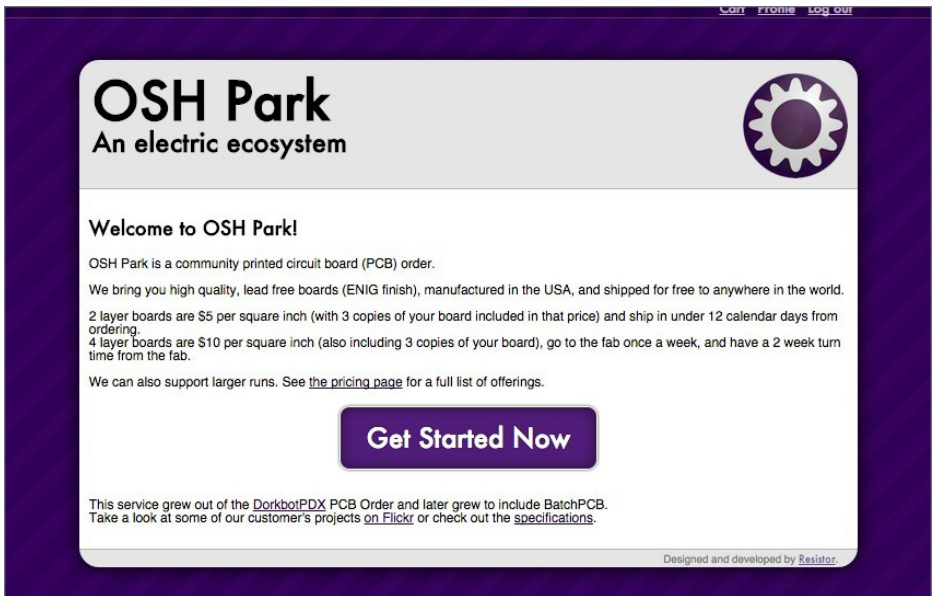

13. This is the OSH Park website main screen. To upload my design, I clicked the large “Get Started Now” button. The following steps are almost as simple.

flasher circuit was combined with 72 other designs, totaling 639 individual boards on the panel.

There are many quality vendors, each with their own benefits and drawbacks. Be sure to evaluate the available options and choose the vendor that makes the most sense for your application. I strongly recommend using EDA software that provides industry-standard Gerber file outputs and is not tied to a particular fabrication vendor so that you are free to shop around for the best balance of cost, speed, and quality for your boards.

Final checks, assembly and test

In a few weeks (or days, for the right price), I have a nice, professional-looking PCB in my mailbox. I visually inspect the board and compare it to my design files to make sure it was made correctly. This is much easier with two-layer boards than with more complex boards, because I can see all of the wire traces. Next, I test-place the components and make sure they fit where they belong and don't interfere. Finally, I solder the components in place and test the circuit for function.

If all is well, then I am ready to make as many boards as required, but it is not uncommon to find problems or design errors even now. When I received the first version of the example circuit, I found the transistor was wired incorrectly and the ground connection for the LM556 chip was missing. After correcting these design errors, I resubmitted the design a second time before having a working PCB.

Like many aspects of this hobby, learning to design high-quality printed circuit boards can take some time, study, and practice. The results, however, are well worth the effort. Like a well-made scratchbuilt structure, well-designed and constructed electronics can be a mark of pride for your model railroad empire.



Tips and Tricks

A few tips and tricks for better board designs:

- Keep signal traces as straight and short as practical. Random, winding routes should be a last resort.
- Be sure that traces carrying a lot of current are as wide as practical.
- Avoid right angles when routing traces. Split 90° turns into two 45° bends.
- Line voltage or high voltage circuits require special design rules to make safely. Avoid working with them or seek the advice of someone well versed in high voltage PCB design.
- When using surface-mount components, resist the temptation to crowd them too close together. Leave room for tweezers and a soldering iron.
- Before submitting the design, print a 1:1 scale copy on paper, attach it to a block of foam, and test-place the components on it. This is a good way to make sure that all of the parts fit properly.
- For mounting screw holes, metric M3 is a convenient size since it is close to the hole size for a 1/8" screw, and so will work for either standard or metric screws.
- Don't be afraid to be a bit creative. Especially with through-hole components, traces can often be routed between pins and underneath components to get where needed. You can also shrink the

width of a trace for short distances to “squeeze” between two closely spaced components or pins. ✓

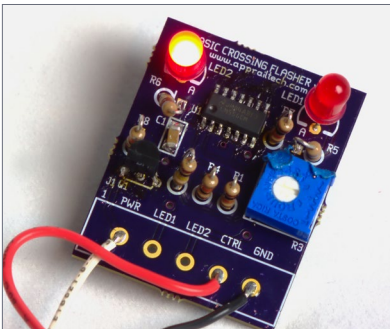

14. After assembling the completed circuit (and fixing a few mistakes), I supplied power and was rewarded with a functioning grade crossing flasher.

SOFTWARE

There are a number of popular Electronic Design Automation (EDA) software packages available to capture schematics and draw PC boards. Most are not much more difficult to learn than track planning software. The following examples all provide Gerber output and are all either free / open-source or provide a free evaluation version. All are available for Windows, Mac OS and Linux.

- KiCad (kicad-pcb.org)
- Autodesk (formerly CadSoft) Eagle (autodesk.com/products/eagle/overview)
- Fritzing (fritzing.org)
- gEDA (geda-project.org)
- Autodesk Circuits (circuits.io)

FABRICATION SERVICES

There are many different fabrication services available, ranging from big commercial vendors to services focused on the hobbyist or DIY designer.

Here are a few fabrication options for the hobbyist designer.

- OSH Park (oshpark.com)
- ITEAD (itead.cc)
- Fritzing Fab (fab.fritzing.org)
- Sunstone Circuits (sunstone.com)
- Dirty PCBs (dirtypcbs.com)
- Seed Studio (seedstudio.com/fusion_pcb.html)

There are dozens of others. Search for “prototype PCB” and evaluate to find the best choice for your application.



MARK UNDERWOOD



Mark Underwood lives in Lexington, KY with his wife and children, but he grew up watching the colorful Chessie diesels hauling coal out of the Kanawha valley in West Virginia. He has a masters degree in electrical engineering and over 20 years experience in the electronics and computer industries.

After brokering a “real estate deal” with his wife, Mark is constructing an N scale layout in a small spare bedroom based on modern industrial railroading in central Kentucky and centered around his freelanced Chestnut Hill & Frost River Railroad. Mark is also active in his local NMRA Division, and enjoys railfanning the local Norfolk Southern and CSX main lines.



[Click here to rate or comment on this article](#)



**A good hobby
product for
under \$1?**

**You've got
to be
kidding.**



As low as

\$0.91 *(weekly)*

TrainMasters TV membership

Invest in gaining a lifetime of hobby insight

Holiday special pricing in effect



Check it out!



www.trainmasters.tv

• **INDEX**



SUBSCRIBE
(free)

• **TABLE OF CONTENTS**

USING CRAFT PAINTS

for Floquil Weathering Colors



DUST



MUD



DIRT

BY BILL KENNEDY

GRIME

Save money by using craft paints to weather ...

AT ABOUT THE SAME TIME THAT I WAS RUNNING low on some of my Floquil Weathering Colors, Gregory M. LaRocca wrote a great article for June 2015 *Railroad Model Craftsman* on using craft paints for airbrushing. June 2015 was also exactly a year



[Click here to rate or comment on this article](#)

after I retired, and a new concept was introduced into my hobby purchases: a budget! The confluence of these two events pushed me to find a low cost replacement for Floquil.

I had used Floquil only for weathering since I always preferred the glossier finishes of Scalecoat and Tru-Color for rail cars, as they eliminated a clear gloss base coat for decaling. Scalecoat's offering in weathering was limited and glossy. Tru-Color offered more weathering colors, but at the time you couldn't brush-paint with them and at \$5.69 an ounce, price had become a factor! When *MRH* released the *Guide to acrylic painting*, I now had viable substitutes but I still didn't have price!

Here's what you'll need to get started:

1. Craft Paints: Americana, Ceramcoat, Folk Art, Apple Barrel avg. cost <\$1.25
2. Airbrush Medium: Liquidtex 8 oz. \$7.50
3. Flow-Aid: Liquidtex 4 oz. \$5.00

Craft paints are frequently on sale at all the craft stores – the last group of Americana I bought at A.C. Moore cost 99¢ each. Craft paints are very thick, so you need airbrush medium which is basically the liquid part of acrylic paint. In other words, it binds and “carries” the pigments. Adding it to craft paints thins the paint without affecting its ability to cover. Art stores carry their own brands of airbrush medium too. Also, you might substitute your own version of Flow-Aid to avoid tip clogging. I've had success with both of the Liquidtex products. Here's Greg LaRocca's formula for a 1 oz. quantity:





1. Full strength brush-outs.



2. Liquitex brand Airbrush Medium and Flow-Aid

½ oz. craft paint

½ oz. airbrush medium

½ ml. to 1 ml. of Flow-Aid (I use a medicine eyedropper for this)

Craft paint comes in 2 oz. bottles, so ½ oz. of paint would cost less than 31¢. One-half oz. of airbrush medium costs 47¢. A milliliter of Flow-Aid costs 4¢. So, **an ounce of modified craft paint costs 82¢ plus the cost of your bottle!** The paint is now at brushable viscosity. Depending on the brand(s) you used, you may have to thin with the medium even more for airbrushing. Whatever viscosity you used for Polly S or Polly Scale will work for this paint also. I have a Paasche H and VL and use no smaller than the #3 tip (medium) at about 20 psi.

Matching the colors

I had bought a pre-packaged assortment of five or six Floquil solvent-based weathering colors years ago. I didn't remember all the colors that were in it so I had to guess at some of the colors to include. The colors I still had were Mud, Grime, Dust, Rust, and also a bottle of Rail Brown. I also had a Floquil chip card for added color match confirmation. Unfortunately, the chips for Grimy and Weathered Black were missing. I also used the website Art-Paints.com for color information. Under the Acrylics tab, you'll find all the craft, Floquil Railroad, and Model Masters paints. Clicking on a color will give you the CMYK and RGB values for that color. Using my scanner and my drawing program, Paint.net, I could scan a brushed sample into the program and read the RGB values. This procedure got me into the color-match ballpark. My goal was to match the color with no more than two colors.



3. Craft Paint's four major brands: Apple Barrel, Americana, Ceramcoat, and Folk Art.

Formulas

AB = Apple Barrel AM = Americana CC = Ceramcoat FA = Folk Art

RUST: 2 parts FA 2558 Cinnamon
1 part FA 943 Burnt Sienna

For a lighter, orange rust, use Cinnamon only.

For a darker, red rust, use equal parts of both.

DUST: AM DAO68 Slate Gray

MUD: 1 part AM DAO9 Antique Gold
1 part AB 21390 Khaki

DIRT: AM DAO94 Mississippi Mud

GRIME: 4 parts AM DAO2 White Wash
1 part AB 21390 Khaki

(This formula is actually a bit darker than the brush-out, but represents a more realistic GRIME when airbrushed. Six or eight parts of White Wash to the Khaki would be closer to the original.)



4. Modified Dust and Rust in $\frac{3}{4}$ oz. glass jars, ready for spraying.

RAIL BROWN: 1 part FA 2558 Cinnamon
1 part AM DAO9 Antique Gold
2 parts FA 426 Dark Gray

(This was the only color I couldn't match with two colors. RAIL BROWN is actually more of a green/brown than a brown. To make it more on the brown side, omit the Antique Gold. This was a really hard color to match. I was stuck until I was leafing through one of my weathering bibles, *Weathering* by Tom Mann where he referenced a "greenish-grime mixture" using Polly Scale Rust and Grimy Black. I tried it using Cinnamon and Dark Gray, and it got me close enough to where I just had to add the Antique Gold to bring out the green to complete the match.)

GRIMY BLACK: CC 2436 Charcoal

(This actually a match of Tru-Color flat Grimy Black. For a "grayer" black, just add some White Wash. For a grimier (very dark brown) shade use the FA Dark Gray which leans toward umber.)

What I learned

I thought that because craft paints are very inexpensive, the pigment would not be finely ground. Surprisingly, it's quite good! The Folk Art brand is thicker than the others and the application nozzle [5] on the top is bigger than the other brands, so you'll have some difficulty measuring against the other brands. Since the bottle cap thread sizes are all the same, you could clean a cap from another brand to equalize the output. The FA Dark Gray was so thick I had to add some airbrush medium to get it to come out of the bottle in drops instead of a caulk-like ribbon. A battery-powered mixer made mixing the thicker paints a dream instead of a chore. I got mine from Micro-Mark. Best prices on airbrush medium, Flow-Aid and bottles were online. The little cups that come on top of liquid medicines are great mixing cups.



5. Standard nozzle on the left, Folk Art is on the right.

The actual brush-out of two colors didn't translate well in the photo. Mud is darker and less green-tinted. Rail Brown is more brown than pictured.

My next project with these paints is to do some matching of non-weathering staples such as boxcar red, zinc chromate primer, tuscan, reefer colors, Pullman green etc. Give this paint a try. You'll like it, and it will never break the bank!



[Click here to rate or comment on this article](#)



BILL KENNEDY

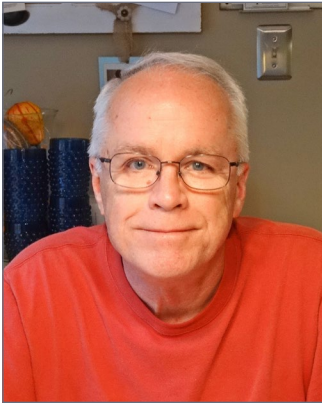

Bill is a retired wholesale hardware salesman who lives with his wife, June, in Shamong, NJ. Because of the time demands of family and work, Bill only had time to build cars and structures before retirement. The layout is now designed, and construction will begin soon. It will be a freelance design using the Western Pacific as the prototype and set in the steam/diesel transition era. Besides trains, Bill also spends his time with family, two grandsons, his pool and yard. Bill is also active in his local NMRA division.



[Click here to rate or comment on this article](#)

IT'S HERE!

RAILCREW

SWITCH MACHINE

WITH ROTATING TARGET!

INCLS. DIFFERENT STANDS & DIFFERENT TARGETS!



WALTHERS[®]

MAKING RAILROAD HISTORY[™]

MAKING RAILROAD HISTORY[™]
WALTHERS[®]

NO
KIT

CORNERSTONE[®]

CONCRETE STREET SYSTEM

Molded in Concrete Colored Plastic

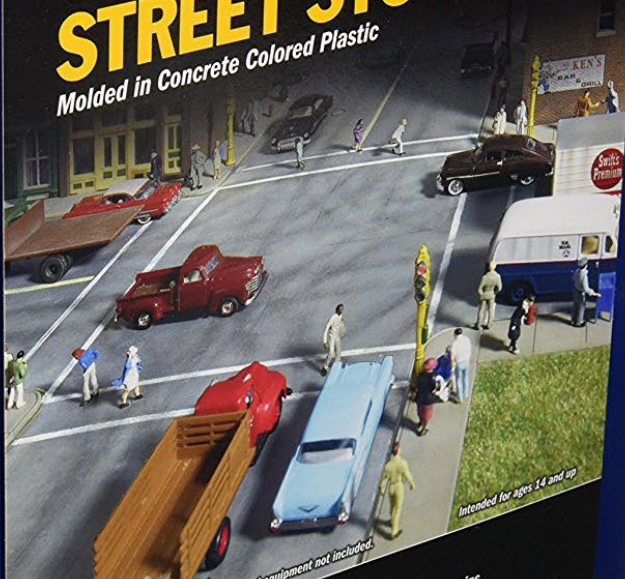

Intended for ages 14 and up

Kit shown assembled and painted.
Figures, vehicles, scenery items and railroad equipment not included.

Features:

- Curved Panels for Right & Left Turns
- One Complete Intersection
- Concrete Sidewalks, Curbs, Alley & Driveway Entrances
- Sewer Grates, Storm Drains and Fire Hydrant Details
- Builds Approximately 25 Inches of Roadway
- Works with Other Cornerstone Street System Components

Required for Completion: Plastic Glue • Water Based Glue • 5/16" Drill • Modeling Knife • Acrylic Paint Recommended

CORNERSTONE[®]

1. This is the
Walthers Concrete Street
System discussed here.



[Click here to rate or comment on this article](#)

Walthers Cornerstone Concrete Street System tips

BY DIRK P. REYNOLDS

Can't find the directions for how to use this system? Here's some help ...

I AM CURRENTLY WORKING ON A SMALL TOWN module, and was envisioning what the town's streets might look like. I went digging through my stash and pulled out the Walthers Cornerstone Concrete Street System to use for my streets.

Unfortunately, I discovered my set had no directions on how to assemble this system! So I put this little article together for those of you in the same fix ...

Here is what I started with [3]. I know, it looks like a mess!

I find it hard to believe Walthers would just “assume” (and we know what that means) you can figure out how to put something together without even a picture. Or maybe my sets had directions and they got lost? Anyhow, I figured it out.

First, let's see what we have to work with [4]. We have straight sidewalks, straight road sections, curved road sections, sidewalk



WALTHERS CONCRETE STREET SYSTEM | 3

corners, and sidewalks with driveway entrances. There are also detail parts such as curbs, grates, and manhole covers.



2. If you visit some swap meets or check on eBay, you can often get a good deal on this street system.

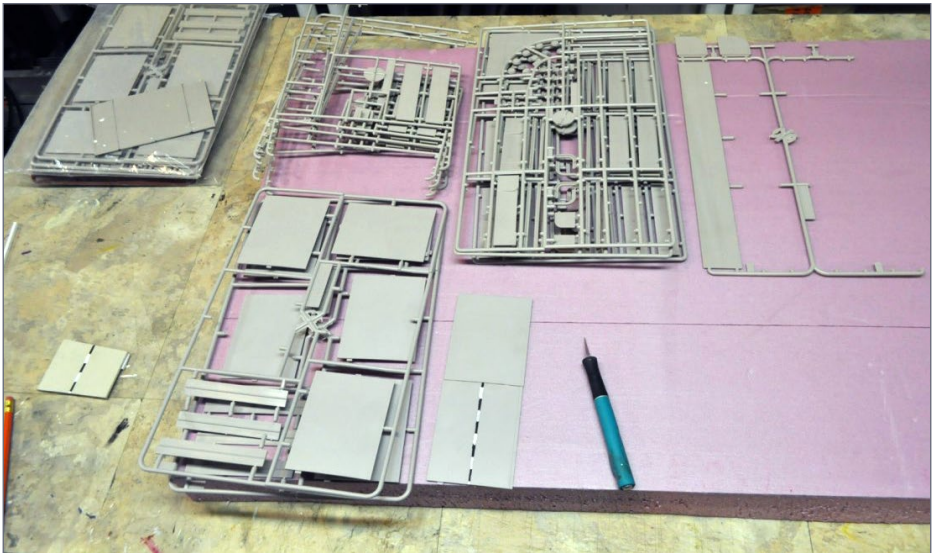

3. I started taking inventory of what I had.

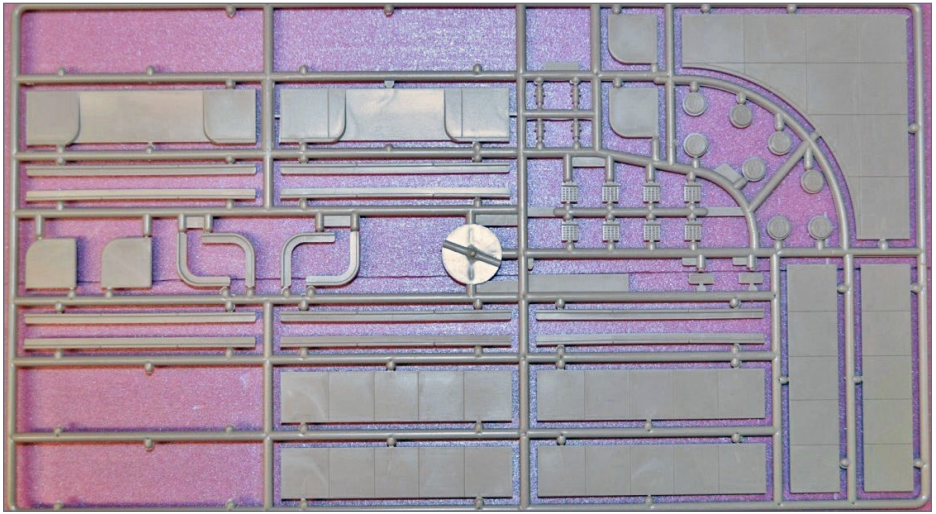

4. A closer look at what comes in this street system set.

How it goes together

I am going to show you in picture form how I put things together. I did find a diagram in one package for the grade crossing set[5], which helped.

I was able to figure out how the parts fit together [6]. From left-to-right we have: sidewalk, curb, roadway, centerpiece, roadway, curb, and the other sidewalk.

When I test-fit the pieces together, I noticed Walthers did an excellent job providing a crown to the street so the water drains into the curbs. This is where the drain grates would be located.

Planning the streets

I remember going to the train shows and seeing those small town modules with a narrow road and sidewalks running through the module. Understanding street dimensions and layout can be



5. I did find a diagram in the grade crossing package, but it's rather sketchy.

WALTHERS CONCRETE STREET SYSTEM | 6

tricky, and more than a few modules seem to have made things too narrow and cramped.

It is always a good idea to try your ideas out first before cutting and fixing things in place!

To this end, I explored some street layout options on some foam [7].

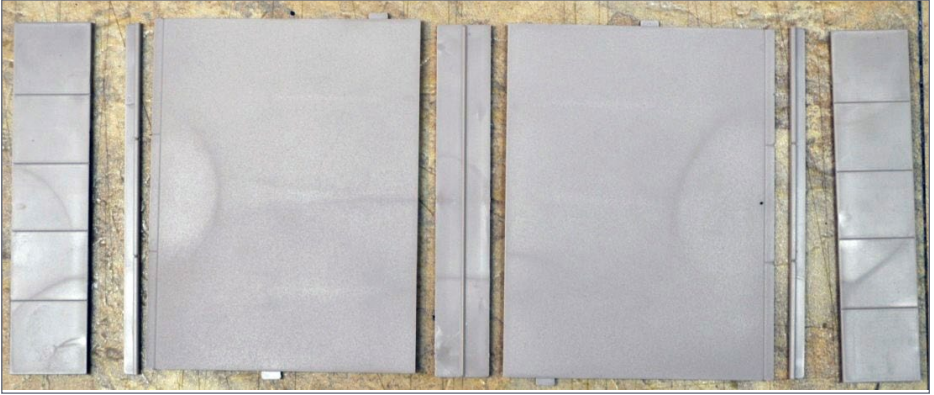

6. Here is how the parts fit together.



7. I started exploring some street placement using foam.

WALTHERS CONCRETE STREET SYSTEM | 7

It helps to have a pre-made kit to assist in laying out a town's streets properly. I mocked-up one with some different options to see what space might be needed.

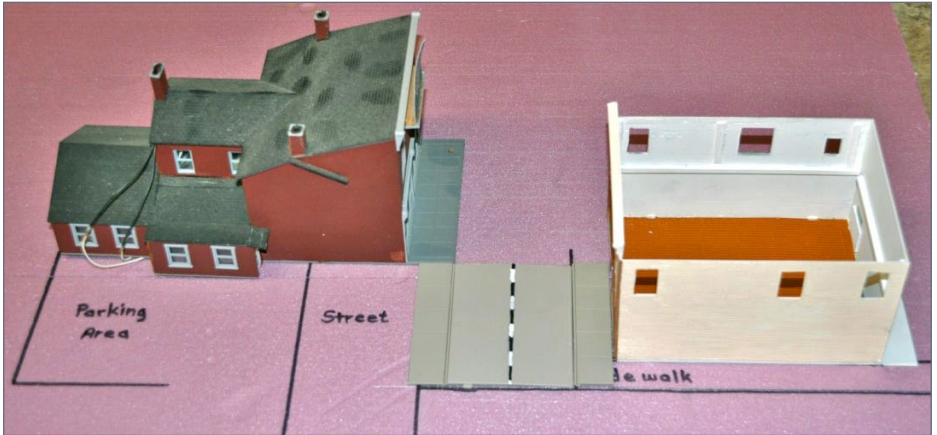

8. Mocking up street options and parking.

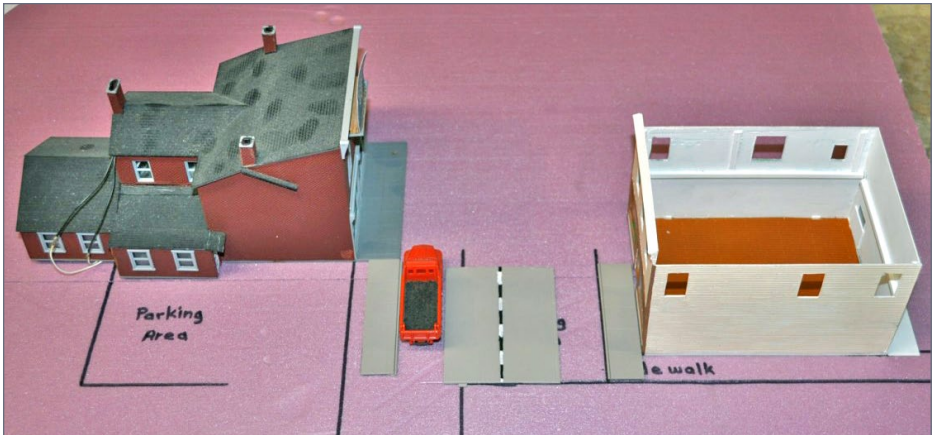

9. With this option, I'm determining the space needed for parallel parking on the street.



10. I applied Liquid Nails adhesive evenly to one piece of foam in preparation for laminating it to another piece of foam.

It becomes apparent that space might be a problem when you start thinking about parking [8]. Where do the town patrons park? You may need to add space for parallel parking along the street, for instance [9].

Remember to think about parking when you lay out your streets with this system.

Preparing the town foam module base

In order to make my foam mockup more permanent, I laminated two pieces of foam and sealed them (see the sidebar: “Sealing the foam”).

To laminate the two pieces of foam, I used Liquid Nails for projects and foam board adhesive [10]. I spread the Liquid Nails evenly with an automotive tool used for spreading Bondo.

I then put the two pieces together.

WALTHERS CONCRETE STREET SYSTEM | 9

Once I had the foam assembled and sealed with paint, I boxed-in the sides with 1/4-inch solid-birch hardwood and painted the sides black. I drew the lines for the road and where the row of buildings will be located [11].

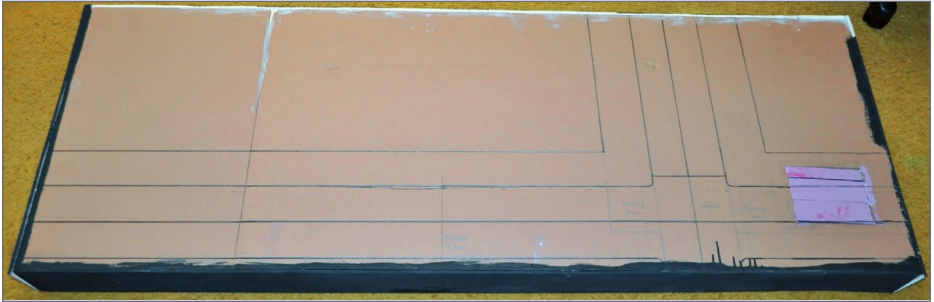

11. Here is the sealed and laminated foam, marked for my street locations.



12. Coat the pavement pieces with a light spray of gray primer.

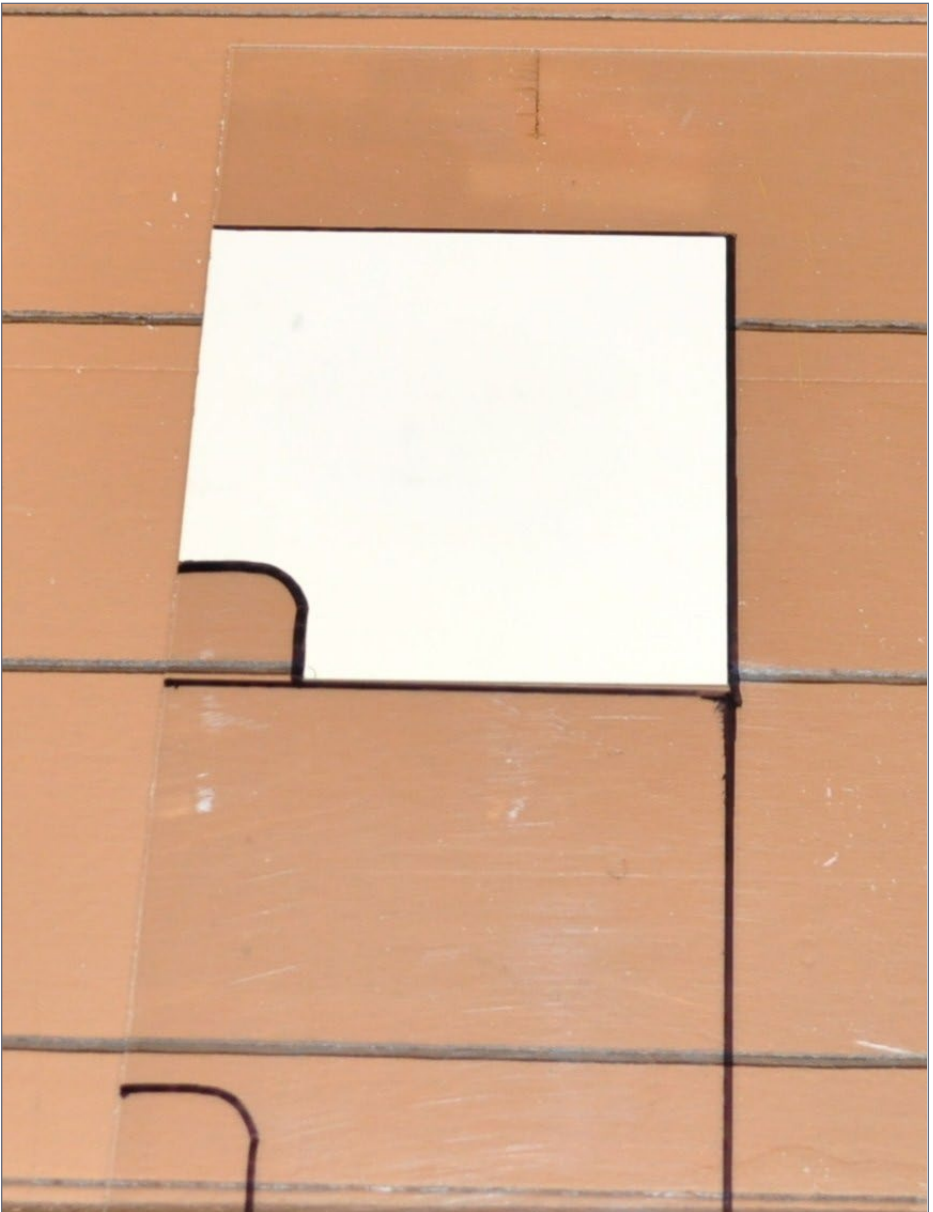

13. I didn't have enough corner pieces for the intersection, so I made my own from styrene using a clear plastic template drawn using one of the kit pieces.



WALTHERS CONCRETE STREET SYSTEM | 11

But first, they need to be painted.

The cast plastic doesn't represent concrete very well. I found it easiest to use a rattle can to spray the pieces a more appropriate concrete gray color [12].

I ran into a problem at the intersection. When reviewing my stash, I realized I had only two of the four corner pieces I would need.

I thought about buying another, however, upon looking up the price of the kit at retail today, I was shocked to see it is \$19.98! That's a lot more than I paid for these sets at swap meets over the years.

I used a piece of correct-thickness of styrene and made my own corner pieces [13, 14].

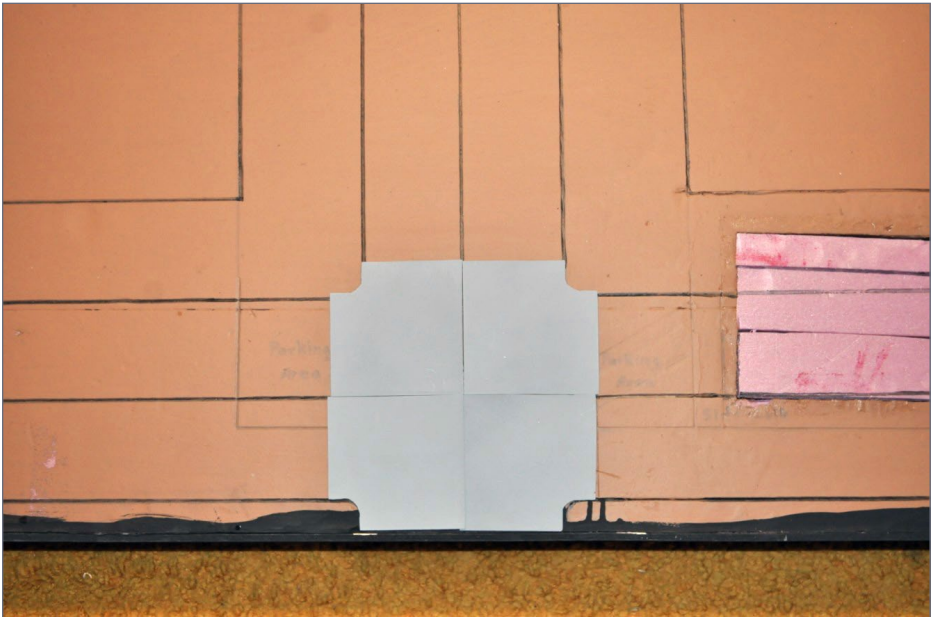

14. Here is the corner intersection made using my homemade styrene pieces.

WALTHERS CONCRETE STREET SYSTEM | 12

There you have it. The Walthers Cornerstone Concrete System assembled and applied to a town module [15].

Watch for these sets at train shows so you can complete your system for a good price!



15. This is the street under construction by applying kit straight pieces to my homemade corner pieces.



[Click here to rate or comment on this article](#)



SEALING THE FOAM

Anyone who has worked with foam for a long-term project like a layout may have noticed the foam may shrink or warp.

If unsealed, the foam can also release fine particles that float in the air and look like dust. This “dust” cannot be good for the lungs! Unsealed foam can also shrink, causing problems later for track and module joints!

Therefore, I make sure all foam I use as a layout base is sealed on the top, bottom and along all sides.

I use latex water-based brown paint for my sealer. The brown paint color helps the module surface look like brown dirt, which is handy later when it comes time to scenic the module.



16. Sealing the foam with latex paint is an important step, not to be ignored.



[Click here to rate or comment on this article](#)

DIRK P. REYNOLDS



Dirk Reynolds has been model railroading since the dinosaurs roamed the earth. His family comes from Dupou, IL, and his grandfather engineered the “doodlebug” motor car that ran from St. Louis, MO to Marion, IL.

Dirk also ran his own hobby shop for nine years in Dupou, under the name of Reynolds Railways. It closed in early 2010, but he is now operating out of his home in Columbia, IL under the name Dirk’s Trains.

He attends all the local train shows, and runs The Warrior Express show that began in February 11, 2012 in Arnold, MO. Contact Dirk at comptrain2002@yahoo.com.



**Click here to rate or
comment on this article**





WHAT'S NEW on TMTV!

Start Small. THINK BIG.

Layout operation!

TOMA
THE ONE-MODULE APPROACH

NOTCH 8

Weathering steam with an airbrush

THE BACKSHOP CLINIC

Photo manipulation & structures

DCC DECODED

New ESU WiFi DCC system

Railway Life

Railway Life documentary

Become a member >>

Holiday special pricing in effect

www.trainmasters.tv

Brought to you by

MRH
MODEL RAILROAD HOBBYIST

MRH Subscriber? Get your 10% off coupon code here:

Get Subscriber
10% off code



LOOK

column



[Click here to rate or comment on this article](#)

JEFF SHULTZ
.....

SCALETRAINS.COM TIER IV GEVO AN HO SCALE MODEL OF ONE OF THE MOST MODERN LOCOMOTIVES IN NORTH AMERICA ...

FAST ON THE HEELS OF THEIR WIDELY PROCLAIMED SD40-2 model, ScaleTrains.com has released the General Electric Tier IV GEVO locomotive in HO scale. Available in both their Operator and Rivet Counter brand, the Tier IV has only been in existence in prototype form since 2012. There are two GE designations for the Tier IV GEVO locomotive – ET44AC (Evolution series Tier 4, 4400hp, AC traction) and ET44C4 (C-C wheel arrangement, 4 traction motors). CSX refers to their Tier IV locomotives as ET44AH, where the H apparently stands for High Adhesion, due to a software upgrade. The ScaleTrains.com Tier IV models are licensed by GE.

ScaleTrains.com provided MRH with two models, the Operators brand Canadian National #3052 and the Rivet Counter brand

▶ **NEW PRODUCT FIRST LOOK**



FIRST LOOK | 2

Canadian National #3062. Both models share the same chassis, motor, and drive train, featuring all-wheel drive and electrical pickup. Both models also have the 5,300 gallon fuel tank with an external waste retention tank and air tanks.

The Rivet Counter model features factory applied prototype specific details, including “late” style front and rear end handrail profiles, Canadian style walkways with etched metal see-through slotted grating and see-through slotted stepwell steps, a rear Canadian “rock pilot,” cab roof antenna domes, nose door without a window, brass Nathan AirChime K5HLR2 horn, etched metal see-through grills for the dynamic brake intakes and exhaust, and 40 etched metal see-through intake and exhaust grilles for the radiator compartment, as well as many other details and features. It includes operating red DPU marker lights, deck mounted front and rear operating ditch lights and ScaleTrains.com metal semi-scale Type E knuckle couplers in a semi-scale coupler buffer.

All Rivet Counter models features a dual-mode ESU LokSound 4.0 decoder with Full Throttle software, dual cube-type speakers, and accurate sounds for a locomotive equipped with a GEVO-12 prime mover. They also include factory installed wire grab irons, snowplow, spare knuckles, trainline hoses, 3-hose MU clusters, uncoupling levers, windshield wipers, mirrors, fuel tank mounted electronic bell and other details.



1. Operators CN #3052 (left) and Rivet Counter CN #3062 (right).

FIRST LOOK | 3



2. Engineer side view. Rivet Counter, top; Operators, bottom.



3. Conductor side view. Rivet Counter, top; Operators, bottom.

FIRST LOOK | 4

The Operator brand model has a lower level of detailing and features, with a shell that is pre-drilled for grab irons, coupler cut levers, MU cables and other details that will be available separately in an upgrade kit. All of these details are factory applied to the Rivet Counter model. The model includes operating front ditch lights, snowplow, nose door with window, sunshades, and brake wheel. While decorated for Canadian National, it does not include the “Canadian” specific details found on the Rivet Counter model. It is equipped with ScaleTrains.com semi-scale plastic Type E knuckle couplers.

The Operator model is DCC ready with a 21 pin connector, suitable for any MTC21 equipped decoder such as the ESU LokPilot or LokSound, Digitrax DH166MT or DH126MT, NCE D16MTC, TCS EUx21 and WOW121-Diesel, or SoundTraxx TSU-21PNEM and ECO-21PNEM.

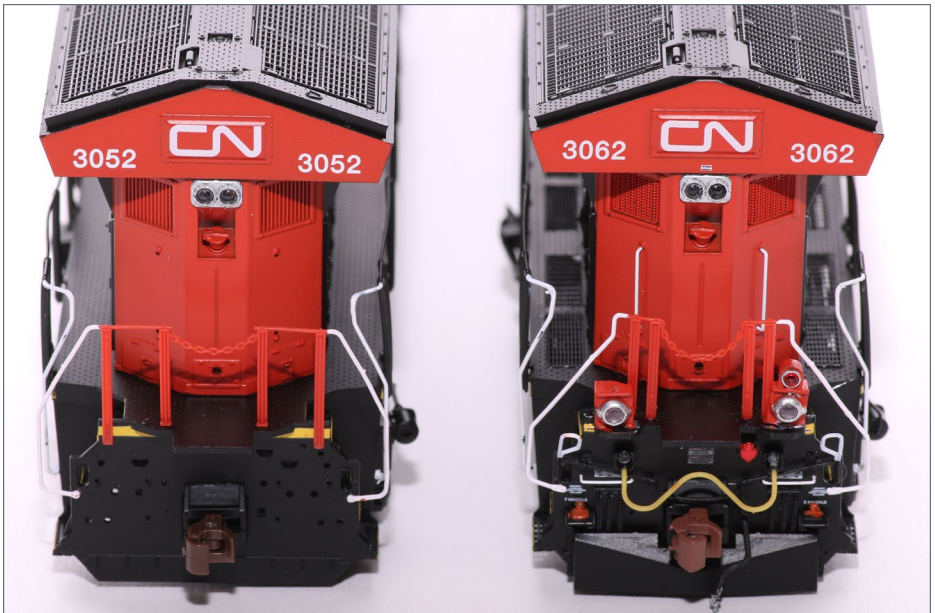

4. Rear view. Operators, left; Rivet Counters, right.

FIRST LOOK | 5

Both models will operate on 18” radius track, but 22” or greater radius is recommended. On my kitchen scale the Rivet Counter model weighs 1 lb. 10.1 oz. and the Operator model weighs 1 lb. 9.5 oz.

Please visit the forum thread for this article for further discussion and more photographs.



5. Front view. Operators, left; Rivet Counter, right.



6. See-through radiator intakes on the Rivet Counter model.

WHAT DOES TIER IV MEAN, ANYWAY?

The EPA has mandated that diesel engines above a certain size have to meet certain emission standards based on the year of their manufacture. All of the information here applies to railroad line locomotives, as other equipment may have had other dates that the standards applied to them.

What Tier applies to a locomotive is based on its date of first manufacture, with locomotives manufactured within the applicable dates having to meet the standards applied to those dates, even if remanufactured at a later date.

The Tier 0-2 standards became effective in 2000, with Tier 0 applying to locomotives originally manufactured from 1973 through 2001, Tier 1 applying to locomotives manufactured from 2002-2004, and Tier 2 to those manufactured after 2005. When the Tier 3-4 standards were adopted in 2008, the Tier 0-2 standards were strengthened for locomotives being remanufactured and Tier 2 was cut off at 2011.

With the 2008 regulations, Tier 3 applies to units manufactured between 2012 and 2014, and Tier 4 (or Tier IV) applies to locomotives manufactured after 2015.

The Tier standards are focused on reducing the amounts of four components of diesel exhaust – hydrocarbons (HC), carbon monoxide (CO), oxides of nitrogen (NOx), and particulate matter (PM). As an example of the reductions required, while a Tier 0 locomotive might be allowed an HC of 1.0, a CO of 5.0, NOx of 8.0 and PM of .22 (all numbers are in grams per brake horsepower hour) the Tier 4 locomotive has to meet a requirement of HC of 0.14, CO of 1.5, NOx of 1.3 and PM of 0.03.

Tier 4 emissions standards were originally thought to require exhaust gas after-treatment in order to meet them, but the railroad industry was resistant to having to manage another consumable fluid on locomotives, not to mention the logistical setup of getting it to them. The most common method of after-treatment involves spraying a water-urea mix known as Diesel Exhaust Fluid (DEF) through the exhaust in a Selective Catalyst Reduction chamber to chemically convert the NOx into Nitrogen and Oxygen.

Both GE with their GEVO prime mover, and EMD with their 1010-series prime movers, have designed their exhaust systems in order to meet Tier 4 standards without the use of exhaust after-treatment. The EMD 1010J is based on the EMD 265 first used in the SD90MAC locomotives and is a 12-cylinder, four-stroke engine, ending the era of two-stroke EMD locomotives. Some passenger locomotives using Caterpillar prime movers do use DEF for exhaust after-treatment.

This is only a very basic treatment of the Tier emission standards. For more detailed information I would recommend going to the websites I used as sources:

dieselnet.com/standards/us/loco.php

dieselforum.org/policy/tier-4-standards

[dieselforum.org/policyinsider/
the-fast-track-to-clean-air-with-clean-diesel-locomotives](http://dieselforum.org/policyinsider/the-fast-track-to-clean-air-with-clean-diesel-locomotives)

[equipmentworld.com/
everything-you-need-to-know-about-tier-4-final](http://equipmentworld.com/everything-you-need-to-know-about-tier-4-final)

and, of course, google.com.



**Click here to rate or
comment on this article**





The Amherst Railway Society Railroad Hobby Show

Our 2018 Show will be

January 27 & 28, 2018

Save the dates!

**Click
to learn
more ...**



About The Show

Every year late in January or early in February, the Amherst Railway Society holds its Railroad Hobby Show at the Eastern States Exposition Fairgrounds (The home of The Big E) in West Springfield, Massachusetts. More than 25,000 railfans and public attended the Show each of the past three years.

The event features real life railroads and scale model railroads, historical societies, travel agencies, art shows, flea market dealers, importers, manufacturers and photographers. You have to see it to believe it!

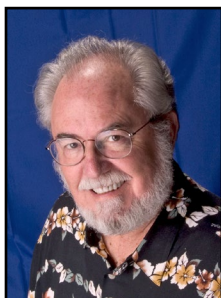

DECEMBER NEWS

column

RICHARD BALE *and* JEFF SHULTZ



**Click here to rate or
comment on this article**

Berkshire Valley Models

Rich Rands, owner of Berkshire Valley Models, has acquired Anvil Mountain Models (AMM) from its former owner, Lowell Ross. The purchase includes the tooling, inventory, and rights to manufacture AMM's full product line including the O scale wagons and horses. Rands is currently working to reissue many of the popular items including the HO scale aerial tram buckets and towers. All future release will be under the name of Berkshire Valley Models. For additional information visit berkshirevalley-models.com.

Dead Rail Installs, Tam Valley Depot

Dead Rail Installs is now the exclusive North American distributor for all Tam Valley Depot dead rail (Power on Board) products. Dead Rail Installs is an established firm owned and operated by

▶ THE LATEST MODEL RAILROAD PRODUCTS, NEWS & EVENTS



DECEMBER NEWS | 2

Pete Steinmetz. The company specializes in sales and installation of radio-controlled battery operated systems for model trains. It is also an authorized dealer/installer for BlueRail Trains, SoundTraxx, and CVP Airwire Products. For additional information visit deadrailinstalls.com. Tam Valley Depot will continue to manufacture and market its core line of products that includes Frog Juicer, QuadLN_S loconet decoder, Turtle Stall motor driver, SwitchWright switch machine, DCC Train Shuttle, DCC Booster, and Octopus III. For additional information visit tamvalleydepot.com...

ExactRail

Chris Brimley has been named vice president of product at ExactRail. The announcement was made following the resignation of Blaine Hadfield in late October. A smooth transition is expected since Brimley has been with ExactRail for the past seven years and has already been involved in some product development...

Railway Prototype Cyclopedia

Railway Prototype Cyclopedia has issued its final publication. Established in 1997 by Edwin Hawkins and Patrick Wider, RPC published 34 editions that presented the prototype, mostly steam era freight cars, in exquisite detail. Each issue will continue to be a valuable resource for prototype modelers. Some back issues may still be available at rpcycpub.com.



NEW PRODUCTS FOR ALL SCALES



Digitrax has introduced the PS2012E 20 amp power supply to replace the PS2012. Delivering more power at 13.8-23 Volts DC with less heat, the PS2012E is more efficient and can operate up to four 5 amp boosters. For more information see your dealer or visit digitrax.com.

.....

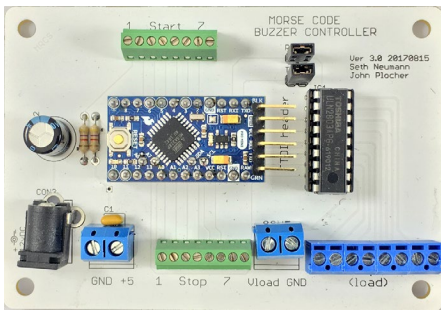

Model Railroad Control Systems has released a “Morse Code Buzzer Controller” that will ring up to seven stations with one or two character Morse code sequences. Each station is buzzed individually with a unique identifying

sequence to notify them that there is a call for them. It also includes an “ambiance output” to randomly play a canned message. The board accepts a push button input and stops when the phone, which must have a suitable contact to provide an isolated ground, goes off-hook. The controller is Arduino mini based and MRCS will program the telegraph codes for each station unless the customer wants to load the sketch containing the codes themselves. For more information visit modelrailroadcontrolsystems.com.

.....

Mt. Albert Scale Lumber has introduced what it is calling “Paint Grade” stripwood. Due to its graining, some basswood



DECEMBER NEWS | 4

stripwood is not suitable for staining, and instead of throwing it away, Mt. Albert Scale Lumber is now selling it as Paint Grade at a discounted price. For more information visit handlaidtrack.com.

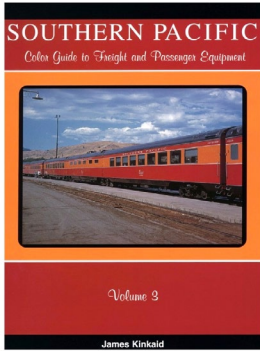

Morning Sun has released a digital reprint of *Southern Pacific Color Guide, Volume 3*, by James Kinkaid. The publication provides detailed information on a wide range of equipment including the articulated three-car dining set, blunt end sleeping cars, double-deck commuter cars, scale test cars, cranes, leased cars, domes, and more. For additional information contact a dealer or

visit morningsunbooks.com.

O SCALE PRODUCT NEWS



Atlas O has announced the lineup of ready-to-run models it plans to release during the second quarter of 2018. Heading the list of O scale models is a class NE-6 caboose. The detailed interior will be illuminated and will

include hand-painted crew figures. Paint schemes will be Conrail, Norfolk & Western, Monongahela, New Haven, Clinchfield, and Seaboard/Family Lines (ex-Clinchfield).

This O scale ready-to-run model is based on a 40-foot wood refrigerator car built in 1930 by Pullman for the Northern Refrigerator Car Co. The model will feature positionable ice hatches, a fishbelly

DECEMBER NEWS | 5



steel underframe, vertical brake shaft, and Bettendorf-type trucks. Separately applied details include door hinges and hardware, ladders, uncoupling bar, and grab irons. In addition to the NRC banana car shown here, decorating schemes will be Jelke Good Luck Products, Soo Line, American Refrigerated Transit, New Haven, and Northwestern.

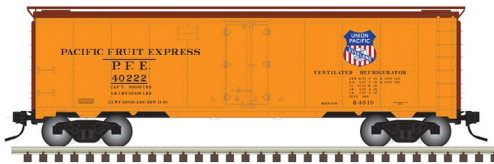

A more modern steel refrigerator car is also included in Atlas O's second quarter release. As shown here the O scale model will be based on a Pacific Fruit Express R-40-10 class reefer as built in the mid-1930s. Additional road names will be Pepper Packing Co., American Refrigerator Transit, Swift, and Santa Fe (Chief slogan).

An undecorated model will be available for both the wood and steel reefers. Atlas O rolling stock is available with appropriate trucks for either 2-rail or 3-rail operation.



Completing Atlas O's second quarter release is a 1:50 scale 2016 Ford F-250 XLT pickup truck. The model is composed of a combination of plastic and diecast parts. The doors, hood, and tailgate open, and the front wheels are positionable. It will be available decorated for Union Pacific and with a colorful American flag theme. For additional information on all Atlas O products contact a dealer or visit atlaso.com.



DECEMBER NEWS | 6

.....



MTH is releasing a model of Union Pacific's latest commemorative locomotive, The Spirit of Union

Pacific. Based on the schemes and colors from each branch of the U.S. military, the locomotive's livery is in recognition of the railroad's part in the military service of many Union Pacific employees. MTH will be releasing the Union Pacific Spirit SD70ACe #1943 in both their Premier Line O Scale Model and the semi-scale RailKing Imperial O Gauge. Each will be offered with a series of freight cars decorated in the colors and logos of each military branch (Army, Navy, Air Force, Marines, Coast Guard) as well as a car featuring POW livery. The locomotives are expected to be available in Spring 2018. For more information see a dealer or visit mthtrains.com.

.....

HO SCALE PRODUCT NEWS



New HO scale kits recently released by **Accurail** include two popular road names on a Pullman-Standard 4750 cu. ft. covered hopper with

triple discharge bays. The New York Central version is based on a prototype built in 1967. The model is also available decorated for Missouri Pacific.

Accurail has released its 36-foot wood boxcar decorated for Chesapeake & Ohio. The HO scale kit represents a double-sheathed prototype built in 1911 with a straight steel underframe, metal roof, and National wood door. All Accurail

DECEMBER NEWS | 7



kits include appropriate trucks and Accumate knuckle couplers. For additional information on all Accurail products contact a dealer or visit accurail.com.



Artitec has released several new models in HO scale during 2017, including a US Army M1A1 Abrams decorated for Desert Storm and a Massey-Ferguson MF 830 combine. Artitec models come fully assembled, painted, and weathered, with some available as kits and in other scales. Artitec models are imported by Reynolds Euro Imports. For further information on Artitec products see your dealer or visit reynolds.com.



Athearn has expanded its lineup of EMD SD70ACe/SD70M-2 locomotives scheduled for delivery next June. The late addition to the production run of the Genesis series HO scale diesel is a UP unit decorated to honor American veterans.



DECEMBER NEWS | 8

The Spirit of Union Pacific is named after a Boeing B-17 Flying Fortress that was funded by UP employees in 1943. The front of the locomotive is painted Air Force silver with a blue strip that represents the former Strategic Air Command's nose sash. It is followed by the Coast Guard's red, white and blue racing stripes, and the Navy's battleship gray. The camouflage at the back is in recognition of the Army and Marines. The "You Are Not Forgotten" motto on the rear of the engine is dedicated to US prisoners of war and those missing in action. Previously announced road names for this release include Norfolk Southern - Illinois Terminal Heritage, First Union Rail (ex FEC), Providence & Worcester (early non-insulated cab), Vermont Railway (prototype patches, early non-insulated cab), CITX, BNSF, and Canadian National (nose door with window, isolated cab).



A Genesis EMD SDP40F decorated in Santa Fe's blue and yellow freight scheme is scheduled for release in October 2018. Notable details include a Leslie S3L horn, illuminated Strato-light, two Sinclair antennas, and blank plates at rear where the steam generators were removed.



Also scheduled for delivery next October is the Genesis GE ES44AC decorated for Canadian Pacific, Union Pacific, and BNSF #5815. The BNSF unit is an LNG Test Unit with "Natural Gas dual fuel" lettering on radiator compartment.

A new run of PC&F 50-foot exterior-post plug-door insulated boxcars is included in Athearn's October 2018 release.

DECEMBER NEWS | 9



Separately applied details on the Genesis series model include see-through etched metal end platforms, brake wheel and housing, brake lever, air reservoir, brake cylinder and triple valve, door closure rods, side ladders, and individual metal grab irons. The model rides on 70-ton roller-bearing trucks with rotating axle caps. Road names will be Nestlé, Illinois Central, Union Pacific (ex-Missouri Pacific), and DRGW/Golden West in Athearn's Primed-for-Grime paint scheme.



Athearn Ready-to-Roll models scheduled for release next October include this 40-foot boxcar. The standout features of the HO scale car are the seven-panel steel doors that are based on a prototype made by the Superior Car Door Company. In addition to the Chicago & Illinois Midland boxcar shown here, road names will be Chicago, St. Paul, Minneapolis & Omaha; Delaware, Lackawanna & Western (Phoebe Snow slogan); Elgin, Joliet & Eastern; Maine Central, and SSW-Cotton Belt (Blue Streak herald).



Also coming next fall is a 200-ton railroad crane. It is accompanied by an idler car with a boom rest. The HO scale model is from upgraded tooling originated by Athearn in

1960. The boom is positionable. Road names will be Canadian



DECEMBER NEWS | 10

Pacific, Southern Pacific, Southern Railway, Santa Fe, and Arizona & California.



Intermodal equipment coming from Athearn next October includes this 48-foot wedge trailer. It features separately applied mud flaps, rubber tires, and positionable landing gear. Carrier names will be ICX, Boston Buffalo, Great Coastal, Thurston, Carolina, IML, and Lee Way.



Athearn plans to release this HO scale Ford C Semi Tractor next October in eight color combinations..



Roundhouse Brand products scheduled for release in October 2018 include an HO scale single dome tank car. It will be produced from upgraded tooling developed by Athearn nearly 50 years ago. Upgrades include separately applied grab irons, knuckle couplers, and machined metal wheelsets. Although the model does not follow a specific prototype it would be akin to a 40-foot 13,000 gallon non-insulated tank car with a short dome. Road names will be C.F. Simonin's, Globe Oil, Norfolk Southern, Shippers Car Line, Frisco, Soo Line, and Union Pacific. Some road names will be available in four packs with unique road

DECEMBER NEWS | 11

numbers. For additional information on all Athearn and Roundhouse products contact a dealer or visit athearn.com.

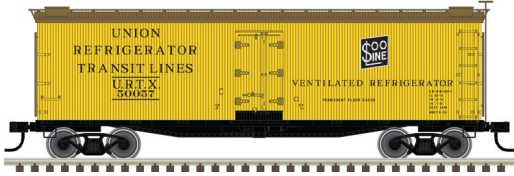

Atlas Model Railroad Company plans to release this wood refrigerator car during the second quarter of next

year. The Master Line model is based on a 40-foot prototype Pullman built for the Northern Refrigerator Car Co. in the mid-1930s. Features will include separately applied door locking bars, grab irons, ladders, and uncoupling bars; a vertical brake shaft, and two different styles of roof hatch. In addition to the URTX/Soo Line car shown here, the HO scale ready-to-run model will be available decorated for NRC Bananas, Jelke Good Luck Products, Multibestos/Gold Seal, American Refrigerated Transit, Northwestern Refrigerator Line, and New Haven Ice Service.

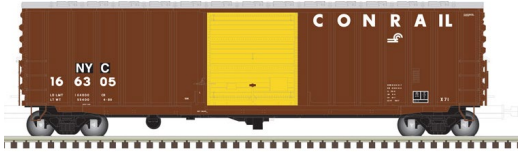

Also scheduled for release during the second quarter of 2018 is a new run of Atlas ACF 50-foot boxcars. Models with exterior post

sides will be available decorated for Conrail, CSX (ex-Conrail NYC patch, above), Frisco, BN, and Chessie System/WM. Cars with smooth sides will be available for MKT, Louisville & Nashville, and Illinois Central. Both versions of the Master Line HO scale ready-to-run model will feature see-through crossover walkways and 70-ton roller-bearing trucks.



Atlas has added code 100 right and left hand curved turnouts to its assortment of track



DECEMBER NEWS | 12

components. The outside radius is 30 inches; the inside radius is 22 inches. Each turnout has diecast points and an isolated, diecast frog with a power contact to optionally energize the frog. Availability is planned for the first quarter of 2018. For additional information on all Atlas products contact a dealer or visit atlasrr.com.

.....

Bowser Trains has announced an August 2018 delivery for HO scale MLW M630 locomotives. Included in this order are five different Canadian Pacific paint schemes, PGE, six BC Rail paint schemes, two Delaware Lackawanna paint schemes, Minnesota Commercial, PGE, and WYNP. The ready to run models come detailed with air hoses, windshield wipers, grab irons, coupler lift bars, and knuckle couplers. Both DC and DCC with sound units will be available. Pre-orders are due by December 15, 2017.



Bowser has also announced plans to produce another run of its HO scale Baldwin DS 4-4-1000 diesel switcher. Availability is scheduled for summer 2018. Features of the Executive Line model include air hoses, windshield wipers, individual grab irons, coupler lift bars, operating headlight, window glass, a can motor with a flywheel, machined nickel silver wheels with RP25 flanges, and knuckle couplers.



Road names will be Bessemer & Lake Erie, Copper Range, Nickel Plate Road, Pennsylvania, Southern Railway, Southern Pacific, and Union Pacific. A choice of two decorating schemes will be available

DECEMBER NEWS | 13

for CNJ, Canadian Pacific, Lehigh Valley, Milwaukee Road, and SMS. The ready-to-run model will be available with a LokSound Select DCC decoder. A DC analog version will be available with a 21-pin socket for installation of an after-market DCC decoder. For additional information on all Bowser products contact a dealer or visit bowser-trains.com.



Fox Valley Models has announced a new version of their Soo Line 7 Post boxcar that features fiberglass panels for letting

additional light into the car. A failed experiment, the panels were replaced with regular ones when the cars were shipped. The HO model will be available in three road numbers. Also available in HO scale will be three new road numbers on the Soo Colormark car. For more information see a dealer or foxvalleymodels.com.



Funaro & Camerlengo is selling a craftsman-style resin kit for an HO scale Union Railroad class H-5 twin-bay hopper

car. The one-piece body kit includes appropriate decals.



Also available from Funaro & Camerlengo is a craftsman resin kit for a Pennsylvania class X37B automobile boxcar. The 50-foot car has double Youngstown sliding doors and 5/5 Dreadnaught ends.



For additional information, including a list of dealers, visit fandckits.com.



InterMountain Railway plans to release a new run of ACF 4650 cu.ft. triple-bay covered hopper

cars early next summer. The HO scale ready-to-run models will have etched metal roof walks, knuckle couplers and appropriate trucks with machined metal wheelsets. Road names will include Soo Line, Norfolk Western, Western Pacific, Milwaukee Road, Norfolk Southern, Wisconsin Central-CN, Allied Chemical, and J.E. Seagram & Sons "Lotus." Undecorated kits will also be available. For additional information on all InterMountain products contact a dealer or visit intermountain-railway.com.



MTH is releasing a model of Union Pacific's latest commemorative locomotive, The Spirit

of Union Pacific. Based on the schemes and colors from each branch of the U.S. Military, the locomotive's livery is in recognition of the railroad's part in the military service of many Union Pacific employees. MTH will be releasing the Union Pacific Spirit SD70ACe #1943 in HO scale in both a DCC-Ready and Proto-Sound 3.0 28-Function DCC equipped version. Each will be offered with a series of freight cars decorated in the colors and logos of each military branch (Army, Navy, Air Force, Marines, Coast Guard) as well as a car featuring POW livery. The locomotive is expected to be available in Spring 2018. For more information see a dealer or visit mthtrains.com.

DECEMBER NEWS | 15

.....



Kadee Quality Products is working on two new HO scale models for release in February. They include this 50-foot PS-1 boxcar decorated for Seaboard Coast Line. The ready-to-run model follows a prototype built in 1962 with 9-foot Youngstown sliding doors. Kadee's version reflects a 1967 repaint.



The second Kadee model due for release in February is an 11,000-gallon ECC-105A insulated tank car decorated for FTLX Gem Automatic Gas. Kadee's

HO version is based on a series of cars built in 1948 with full platforms. The model will be available in two road numbers. For additional information on all Kadee products contact a dealer or visit kadee.com.

.....



ScaleTrains.com is developing an HO scale ready-to-run model of a Pullman-Standard PS-2CD 4785 cu.ft. covered hopper car. Delivery is planned for

spring 2018. The Rivet Counter version of the model will feature rotating bearing caps, factory applied plastic and etched-metal details such as roof hatches and outlet gates, and road name and road number-specific details including variations on the complex end cage.



DECEMBER NEWS | 16

.....



The economy-priced Operator series edition of the PS-2CD 4785 will have fewer factory applied parts and simplified printing. A special detail kit with metal

grab irons, coupler cut levers, train line hoses, and other details is sold separately. Road names for both versions of the PS-2CD 4785 will be Conrail, Penn Central, Cotton Belt, Cargill/TLCX, Staley/TLCX, and Highland Feeders/TLDX..

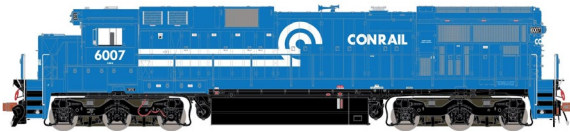

At Trainfest, ScaleTrains.com announced that they would be releasing an HO scale model of the

General Electric C39-8 in HO scale. Purchased only by Conrail and Norfolk Southern, the C39-8 was commonly used as run-through power on CSX, Union Pacific and Southern Pacific, who also leased two Conrail units in the early 1990s. The first run of the Rivet Counter brand locomotives includes units decorated for Conrail, Norfolk Southern and Pennsylvania Northeastern, which owns the only currently running examples. Multiple numbers and variations will be released for each roadname. For additional information visit scaletrains.com.

.....



Schuylkill Iron Works is selling a resin kit for an HO scale Treadwell Slag Car. The kit was produced for SIW by Funaro & Camerlengo. For additional information contact Schuylkill Iron Works, PO Box 3678,

Reading, PA 19606, or phone (717) 421-1561.

.....



At Trainfest, **Tangent Scale Models** announced a new body variation on the PS-2CD 4750 covered hopper, the early body ver-

sion. Available in seven roadnames and undecorated, the models will begin shipping at the end of November. Roadnames in this release are Chicago & North Western (Original 1973), Chicago & Northwestern (ex-RI Re-stenciled) Illinois Terminal (Original 12-73), Missouri Pacific (Original 12-72), PTLX (ConAgra 4-1973), Rock Island (Original 5-73), and SOO (ex-ConAgra 1984+). All models are available in multiple road numbers and feature many car specific details for each paint scheme, including seven different brake systems, three different outlet gates, three different sets of roof hatches, and four jacking pad sets. The models also feature wire grab irons and coupler lift bars, separate air hoses, and 36-inch wheels in 100-ton trucks. For more information see your dealer or visit tangentscalemodels.com.

.....



Walthers has set a late February release date for the next run of Proto series EMD E8A locomotives. Although similar in appearance to the familiar E7, the E8 had a full-length

metal grille along the top of the sides, and four porthole windows. In addition to Southern Railway the locomotive will be available decorated for Illinois Central, and New York Central. The HO scale ready-to-run model will be offered in a choice of either standard DC or with LokSound Select DCC and Sound.



DECEMBER NEWS | 18

.....



Walthers late December release schedule includes a Cornerstone kit for an HO scale Modern Gas Station.



A companion kit for a Car Wash will also be available. Vehicles shown in the illustrations are not included in the kits.



Additional kits coming from Walthers Cornerstone include an Urban Concrete Overpass, compatible Retaining Walls, and an Elevated Commuter Station.



For additional information on all Walthers products contact a dealer or visit walthers.com.



N SCALE PRODUCT NEWS

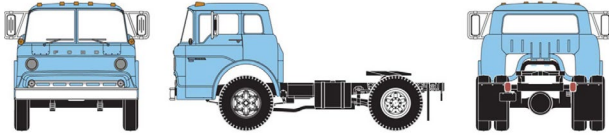

Athearn has scheduled the release of this N scale Ford C Semi Tractor for next

October. The two-axle vehicle will be available in eight color combinations. For additional information on all Athearn products contact a dealer or visit athearn.com.

.....



Atlas Model Railroad Company has scheduled the introduction of a new N scale well-car and container during the second quarter of 2018. The 53-foot ready-to-run car will have a diecast body with cast detail, separate grab irons, and etched metal walkways. The cars will be available decorated for TTX, Florida East Coast, and St. Marys Railway West.



The container has corrugations on the front, sides, and roof. The loading end features

1-3-1 beveled doors. Carrier names will be EMP (Union Pacific), Hub (Norfolk Southern), and UMAX. The containers will be sold in 3-packs with three different numbers.



Atlas' production schedule for the second quarter of 2018 includes a new run of its popular EMD GP30 road



DECEMBER NEWS | 20

switcher locomotive. In addition to the Rio Grande scheme shown here, road names will be Kansas City Southern, Burlington Northern, Baltimore & Ohio, Reading & Northern, Pennsylvania Railroad, and Union Pacific. The N scale model will have directional lighting with golden-white LEDs, dual flywheels, and AccuMate knuckle couplers. The Master Gold series version comes with a factory installed ESU DCC sound decoder. The Master Silver DC version is sound-ready and comes with a speaker to simplify conversion to DCC sound.



Also scheduled for release during the second quarter of 2018 is a new run of Atlas Master Line ACF 50-foot

boxcars. Models with exterior post sides will be available decorated for Conrail, CSX (ex-Conrail NYC patch, above), Frisco, BN, and Chessie System/WM. Cars with smooth sides will be available for MKT, Louisville & Nashville, and Illinois Central. Both versions of the N scale ready-to-run model will feature see-through crossover walkways, and 70-ton roller-bearing trucks.



Completing Atlas' N scale second quarter schedule are two new Trainman series 60-foot

passenger cars decorated for the Reading, Blue Mountain & Northern Railroad. The ready-to-run models are based on C&NW and CNJ steel commuter prototypes. Features of the Atlas model include interior details, diaphragms, roof vents, and window glazing. The cars will be sold in a 5-pack consisting of four coaches and an open-end observation car.

Atlas has added two new transition sections to its assortment of N scale True-Track components. The new items provide a smooth

DECEMBER NEWS | 21



transition from code 65 to code 80 track, or from code 65 to code

55 track. Availability is planned for the first quarter of 2018.

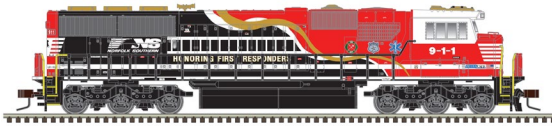

Atlas' Trainfest announcements included an N scale EMD SD60E locomotive

in both the Atlas Master Series Silver and Series Gold, with a test sample present at the show. Paint schemes announced were the standard Norfolk Southern as well as Norfolk Southern 911 - Honoring First Responders, Norfolk Southern 6920 - Honoring Our Veterans, and 6963 - GO RAIL. Equipped with directional lighting with golden-white LEDs, blackened metal wheels, painted handrails, and factory installed Accumate magnetic knuckle couplers, the Silver model will be sound ready and equipped with a speaker for easy conversion to DCC sound, and the Gold model will be equipped with an ESU LokSound decoder with Full Throttle. Delivery was not specified.



Another Trainfest announcement is the ALP45DP locomotive in N scale, along with multi-level passenger cars. The first pre-production sample models were on display at Trainfest. The ALP45DP



will be available in Bombardier Demo, AMT, NJ Transit, and NJ Transit 4534 Bombardier ALP 100th Locomotive Celebration.



DECEMBER NEWS | 22

The passenger cars will be available in AMT and NJ Transit paint schemes. The cars will also feature seat details and LED illumination with separately applied lift lugs, end barriers and rubber diaphragms. For additional information on all Atlas products contact a dealer or visit atlasrr.com.



Centralia Car Shops has scheduled another release of its N scale

Pullman-Standard Lightweight 6-6-4 Sleepers for early summer. Features of the N scale ready-to-run models include wire grab irons, battery operated interior lighting, and truck-mounted knuckle couplers. Road names include Union Pacific (Overland scheme), Southern Pacific (Lark scheme), Southern Pacific (Sunset Limited scheme), Illinois Central, and Rock Island (Golden State scheme).



ATSF cars will be available in Santa Fe's standard gray as well as in

the shadow-line scheme as applied to the prototype to simulate fluting. InterMountain is responsible for marketing Centralia Car Shops products. For additional information contact a dealer or visit intermountain-railway.com.



Fox Valley Models has announced a new version of their Soo Line 7 Post boxcar that features fiberglass panels for letting

additional light into the car. A failed experiment, the panels

DECEMBER NEWS | 23

were replaced with regular ones when the cars were shopped. The N scale model will be available in three road numbers. Also available will be the Soo “All Red” car and two Wisconsin Central cars featuring graffiti weathering. For more information see a dealer or foxvalleymodels.com.



InterMountain Railway plans to release a new run of ACF 4650 cu.ft. triple-bay covered hop-

per cars early this summer. The N scale ready-to-run models will have etched metal roof walks, knuckle couplers, and appropriate trucks with machined metal wheelsets. Road names will include Wisconsin Central-CN, Soo Line, Norfolk Western, Western Pacific, Milwaukee Road, Norfolk Southern, Allied Chemical, and J.E. Seagram & Sons. Undecorated kits will also be available. For additional information on all InterMountain products contact a dealer or visit intermountain-railway.com.

Kato USA has teamed up with Micro-Trains to offer a diesel locomotive and seven assorted freight cars all decorated for Santa Fe. The bundled rolling stock includes an SDP40F diesel, a boxcar, two flat cars, a trailer, a well car with a 48-foot container, and a caboose. This special set will be available exclusively through Kato USA. Delivery is expected in April or May 2018. For additional information contact a dealer or visit katousa.com.

ESU has introduced three new six function LokSound Select Direct Decoders for narrow hood units in N scale. #73100 includes separate LEDs and is for retrofit into pre-2017 Atlas and InterMountain and other locomotives, #73199 includes an SMT



DECEMBER NEWS | 24

LED for upgrading DC versions of LokSound factory equipped locomotives, and #54650 for upgrading DC versions of LokSound factory equipped locomotives. For more information see your dealer or esu.eu/en/start.



Micro-Trains Line is selling an N Scale Denver & Rio Grande Western 70-foot combination mail/baggage car.



Also new is a Norfolk & Western Railway Post Office car. Both of these heavyweight steel head-end cars ride on six-wheel passenger trucks.



New N scale freight equipment from Micro-Trains includes this Atchison, Topeka & Santa Fe 50-foot

Airslide covered hopper car with four discharge outlets. The model is equipped with 100-ton Barber roller-bearing trucks.



This 36-foot Northern Pacific all-steel caboose displays the famous Monad herald and Main Street of the Northwest slogan. Additional ready-

to-run N scale models recently released by Micro-Trains include

DECEMBER NEWS | 25

a 50-foot Boston & Maine boxcar with a 10-foot sliding door, a 40-foot CNW boxcar decorated to commemorate the 1947 Friendship Train, a wood-sheathed truss-rod era boxcar decorated for Heinz Pickles, and a 50-foot NYC boxcar with double 8-foot sliding doors. For additional information on all Micro-Trains Line products contact a dealer or visit micro-trains.com.

Rapido Trains has announced plans to relaunch its N scale GMD-1 diesel locomotive project. Availability is planned for fall 2018. The run will include 1100 series models (below) that represent GMD-1 locomotives rebuilt in the 1980s. The rebuild included 2000 gallon fuel tanks and replacing the original six-wheel trucks with four-wheel Flexicoil trucks recycled from expired GP9 locomotives.



Rapido's 1400 series GMD-1s represent units rebuilt in 1988 with new prime movers and a

new paint scheme. They were rebuilt again in the late 1990s with four-wheel trucks replacing the original six-wheel units.



Rapido's fall production run includes an N scale version of several second-hand 1100 series GMD-1s that were purchased by Cuba in the 1990s. They received either one or two six-wheel trucks in Montreal before



DECEMBER NEWS | 26

.....

being shipped to Cuba. The additional axles were better suited to spread the weight of the locomotive on the light rail used throughout Cuba.



Completing the release are three new numbers for Rapido's popular 1000 series GMD-1 in the original CN green paint scheme. For additional information on all Rapido products contact

a dealer or visit rapidotrains.com.

.....



Walthers plans to release an N scale EMD SW1200 diesel switcher late this month. Road names will be Elgin, Joliet & Eastern; Santa Fe,

Burlington Northern, Denver & Rio Grande, Indiana Harbor Belt, Milwaukee Road, Reading, and Southern Pacific.



The ready-to-run models will be available for standard DC operation only. For additional information contact a dealer or visit walthers.com.

.....

Z SCALE PRODUCT NEWS



New Z scale equipment from **American Z Line** includes an EMD GP38-2 diesel locomotive decorated for Kansas City Southern. Features

include directional LED headlight, traction tires, and an optional plow/pilot.



Also new from American Z Line is a General Electric ES44AC diesel locomotive in Ferromex paint. The model

features working ditch lights. Both locomotive models are DCC-ready for a drop-in decoder.



New Z scale rolling stock includes this Gunderson 60-foot high-cube boxcar. It is available in 12 road numbers. For additional information about all

American Z Line products visit americanzline.com.



At Trainfest **Atlas** announced new Z scale track sections to go along with their previously announced 24 inch flex

DECEMBER NEWS | 28

track. Products announced included a 19 deg. Crossing and Right and Left #6 Turnouts. Delivery was not announced. For more information see a dealer or visit atlasrr.com.

NEW DECALS, SIGNS AND FINISHING PRODUCTS

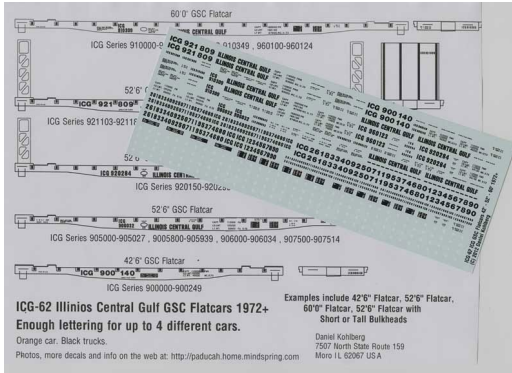

Dan Kohlberg is selling HO scale water-slide decals for Illinois Central GSC flat cars. The set has enough material to correctly decorate four different cars from 1972 forward. For additional information visit home.mindspring.com/~paducah/icg62.htm.

home.mindspring.com/~paducah/icg62.htm.



Precision Design Company sells several selections of HO scale hazardous warning placards and placard holders.

Also from PDC are sets of HO scale RBOX "Ghost Lettering" sets, that allow you to combine the elements to make up your own ex-RBOX boxcars. For complete information visit pdc.ca/rr/catalog.

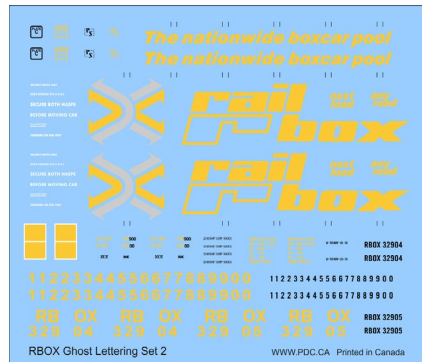

DECEMBER NEWS | 29

.....



New HO scale lettering sets from **Prime Mover Decals** include Morrystown & Erie diesels. Set #PMD-007 will decorate M&E Alco diesels numbered 14 through 19 in the post 1980 scheme.



Also new are lettering sets for Delaware, Lackawanna & Western cabooses. Set #PMD-029 covers steel cabooses, set #PMD-030 covers wood cabooses. PMD reports that it is working with a new decal printing source and will be re-issuing many popular sets that have been out production for some time. For additional information visit primemoverdecals.com.

.....

DISCLAIMER

The opinions expressed in this column are those of the writer and do not necessarily reflect the opinion of *Model Railroad Hobbyist* or its sponsors. Every effort is made to provide our readers with accurate and responsible news and information, however, neither *Model Railroad Hobbyist* or the writer of this column can be held responsible for any inaccuracies or typographical errors that may inadvertently appear in this column.





BRIEFLY NOTED AT PRESS TIME ...

At Trainfest **Accurail** showed a pre-production sample of a new 36-foot Fowler boxcar. The HO scale model is based on the popular Fowler Patent single-sheathed wood boxcar developed by W. E. Fowler, the master car builder for the Canadian Pacific Railway. The initial release, planned for early next year, will be decorated for CI&L (Monon) ...

Additional new items spotted at Trainfest include both HO and N scale versions of an **Atlas** 85-foot flat car with an open-type deck, container pedestals, and 100-ton trucks.

Marklin displayed a pre-preproduction sample of an HO scale Union Pacific 4-6-6-4 locomotive. Features included DCC with sound, six powered driver axles, and a wood presentation box. No word on a release date. **Walthers** quoted an April release date on several versions of a new Pullman-Standard 60-foot flat car. **Bluford Shops** announced plans to produce a new N scale International Car Co. bay-window cabooses. The new tooling will cover phase 1, 2, 3, and 4 of the standard steel cabooses plus the unique half-bay window version favored by NYC and Conrail. Release dates are pending ...



SEND US YOUR PRODUCT ANNOUNCEMENTS

If you are a hobby manufacturer with a product announcement, just [click here](#) and submit your announcement to us. Our web site and free magazine reach continues to grow, so get on board this new media train! ■

DECEMBER NEWS | 31

.....

Mask Island Decals is selling a resin kit for a Rock Island pulpwood car. The HO scale model is based on a Biddle Yard rebuild circa 1951. The kit includes a resin body, wood deck, wire grab irons, underframe parts, and decals. Appropriate trucks without wheelsets are included. Also new from Mask Island are HO scale decal sets for Reading 50-foot DF and DFB PS-1 box cars. Each set has different data schemes appropriate to each car class ...

Morning Sun Books has released a digital reprint of *Chicago & North Western in Color Volume 2: 1954-1958*. The book includes 240 vintage photos that cover the final days of steam and the evolution of the early diesel fleet...

Walthers has sold the tooling for its N scale fluted- and smooth-side passenger cars to **Lowell Smith**, of Gresham, OR. Future products will be marketed under the brand name of RailSmith Models. The first release is tentatively planned for the second quarter of 2018...

InterMountain is preparing new tooling for an N scale Paducah GP10 diesel locomotive. A mid-summer release is planned. Watch for more details next month including a final selection of road names...



Click here to rate or comment on this article





SELECTED EVENTS

December 2017

(Please note that many events charge a fee. Check individual info website for details.)

FLORIDA, THE VILLAGES, December 14-17, Christmas Train Show, at Colony Cottage Recreation Center, 510 Colony Boulevard. Sponsored by The Villages Model Train Club. Info at thevillagesmodeltrainclub.com.

ILLINOIS, CHICAGO, December 2-3, Lake Shore Model Railroad Association Annual Open House, at Calumet Park Field House, 9801 South Avenue G. Info at lakeshoremodelrr.org. Note: loud autolaunching video on website.

INDIANA, INDIANAPOLIS, December 9, Christmas Train Show & Swap Meet, sponsored by Naptown & White River Model Railroad Club, at Emmerich Manual High School, 2405 South Madison Avenue. Info at naptownrr.org.

MASSACHUSETTS, MARLBOROUGH, December 2-3, Annual New England Model Train Expo sponsored by NMRA Northeastern Region HUB Division, at Best Western Royal Plaza Trade Center, 181 Boston Post Road West. Info at hubdiv.org.

NEW JERSEY, EGG HARBOR TOWNSHIP, December 9-10, Train Show sponsored by Shoreline Model Railroad Club, at Atlantic Christian School, 391 Zion Road. Request info from Dennis Weiss at trains1971@comcast.net.

NEW JERSEY, NORTH HALEDON, December 2-3, and 9-10, 60th Annual Open House sponsored by Garden State Model Railway Club at 575 High Mountain Road. Info at modelrailroad-show.com.

SELECTED EVENTS | 2

NEW YORK, ALBANY, December 3, Annual Great Train Extravaganza, at Empire State Convention Center. Info at gtealbany.com.

NEW YORK, ROCHESTER, December 9-10, RIT Tiger Tracks Train Show & Sale, at Gordon Field House, Rochester Institute of Technology, 1 Lomb Memorial Drive. Info at ritmrc.rit.edu/tigertracks.

OHIO, LIMA, December 16, Train Town Show & Swap Meet, sponsored by NMRA NCR Three Rivers Division at Allen County Fairgrounds, Merchants Building, 2750 Harding Highway. Info at div3.ncr-nmra.org.

January 2018, by location

FLORIDA, COCOA BEACH, January 4-6, Prototype Rails RPM Meet, hosted by Mike Brock at Cocoa Beach Hilton Oceanfront Hotel. Info at prototyperrails.com.

FLORIDA, STUART, January 20-21, Annual Train Show, sponsored by Martin County Model Railroaders, at Martin County Fairgrounds, 2616 SE Dixie Highway. Info at martincountymodelrailroaders.org.

GEORGIA, ROSWELL (Metro Atlanta), January 13, 2018, O Scale South 2018, at Cross of Life Lutheran Church, 1000 Hembree Road. Sponsored by the Southern O Scalers and the Model Railroad Club of Atlanta. Info at oscalesouth.com.

ILLINOIS, WHEATON, January 14, Great Midwest Train Show, at DuPage County Fairgrounds, 2015 Manchester Road. Info at greatmidwesttrainshow.com.

MASSACHUSETTS, WEST SPRINGFIELD, January 27-28, Amherst Railroad Hobby Show, sponsored by the Amherst Railway Society, at Eastern States Exposition Fairgrounds, 1305 Memorial Avenue (enter at Gate 9). Info at railroadhobbyshow.com.



SELECTED EVENTS | 3

MINNESOTA, WOODBURY, January 20, Model Railroad Flea Market & Train Show, sponsored by Newport Model Railroad Club, at Woodbury High School, 2665 Woodlane Drive. Request info from Ed Petry at sierraed@usfamily.net.

Future 2018, by location

CANADA, BRITISH COLUMBIA, BURNABY, May 4-6, 2018, 3rd Annual 7th Division PNR Modellers Meet, at Simon Fraser University (Burnaby Campus), West Mall Centre. Info [facebook.com/RailwayModellersBritishColumbia](https://www.facebook.com/RailwayModellersBritishColumbia).

CANADA, ONTARIO, COPETOWN, March 4, Prototype Modellers Show. Info at [facebook.com/CopetownShow](https://www.facebook.com/CopetownShow).

CALIFORNIA, SAN BERNARDINO, April 28, Western Prototype Modelers meet, at Santa Fe/Amtrak Station, 1720 West Third Street. Info at railroadprototypemodelers.com.

MARYLAND, ROCKVILLE, August 22-26, 2018, 50th O scale National Convention, co-sponsored by NMRA MER, Standard Gauge, Narrow Gauge, P48 and Traction modelers, at Rockville Hilton Hotel, 1750 Rockville Pike. Info at 2018oscalenational.com/newsletters/september-2017-newsletter.

MASSACHUSETTS, AUBURN, February 25, Greater Worcester Model Train Show & Sale, sponsored by Worcester Model Railroaders, Inc., at Auburn Elks Club, 754 Southbridge Street. Info at wmrr.org.

MISSOURI, KANSAS CITY, August 5-12, 2018, NMRA National Convention and National Train Show. Host hotel is Westin Kansas City at Crown Center. Info at kc2018.org.

OHIO, MARION, April 26-28, Central Ohio RPM, at Marion Union Station. Info at [facebook.com/groups/438383252883060/about](https://www.facebook.com/groups/438383252883060/about).

SELECTED EVENTS | 4

OREGON, PORTLAND, February 10, Bridgetown Railroad Prototype Modelers Meet. Info at facebook.com/groups/2001136043323501/about.

PENNSYLVANIA, VALLEY FORGE, March 23-25, RPM Meet, at Desmond Great Valley Hotel & Conference Center. Info at rpm-valleyforge.com.

VIRGINIA, ROANOKE, April 21-22, Coalfield Railroads RPM & Scale Train Show, at Valley View Holiday Inn. Info at facebook.com/TheCoalfieldRailroadsRPMMeetAndScaleTrainShow.

WASHINGTON, VANCOUVER, February 17, Railroad Swap Meet, sponsored by Spokane, Portland & Seattle Railway Historical Society, at Warehouse 23, 100 Columbia Street. Request info from Jerry Pickell at pickell5141@msn.com.

WISCONSIN, CEDARBURG, March 11, 23rd Annual Model Railroad Show & Swap Meet, sponsored by Metro Model Railroad Club, at Circle B Recreation Center, 6261 Highway 60. Info at metrorrclub.org.

Beyond 2018

UTAH, SALT LAKE CITY, July 7-13, 2019, NMRA National Convention and National Train Show. Host hotel is Little America Hotel. Info at nmra2019slc.org.

MISSOURI, ST. LOUIS, July 12-18, 2020, NMRA National Convention and National Train Show. Host hotel is Hilton St. Louis at the Ballpark. Info at gateway2020.org.

CALIFORNIA, SANTA CLARA, 2021, NMRA National Convention. ■



Click here to rate or comment on this article



Clickable advertiser index – 1

[Accu-Lites](#)

[Altoona Model Works](#)

[American Ltd \(San Juan\)](#)

[Amherst Railway Society](#)

[Archer Fine Transfers](#)

[Athearn](#)

[Atlas Model Railroad Co.](#)

[Bachmann](#)

[Bachrus](#)

[Backdrop Junction](#)

[Berrett Hill Trains](#)

[Black Cat Publishing](#)

[Blair Line](#)

[Bowser](#)

[Coastman Scenic Products](#)

[Caboose](#)

[Canyon Creek Scenics](#)

[Coffman Graphics](#)

[Crow River Products](#)

[Digitrax \(2 page spread\)](#)

[East Penn Traction Co.](#)

[El Dorado 3rd PlanIt](#)

[ESU LokSound](#)

[Fast Tracks](#)

[Fine Scale Miniatures](#)

[Good Deals DCC](#)

[Great Decals](#)

[HO Diesel Supply](#)

[Iowa Scaled Engineering \(ISE\)](#)

[ITLA Scale Models](#)

[Kadee \(1\)](#)

[Kadee \(2\)](#)

[Ken Patterson.com](#)

[Lights 4 Models](#)

[Litchfield Station](#)

[Logic Rail Technologies](#)

[Main Street Heritage Models](#)

[Micro-Trains Line](#)

[Modeltech Studios](#)

[Model Railroad Benchwork \(1\)](#)

[Model Railroad Benchwork \(2\)](#)

[Model Railroad Control Systems](#)

[Mountain Subdivision Hobbies](#)

[Mt Albert Scale Lumber](#)

[MRH Store \(1\)](#)

[MRH Store \(2\)](#)

[MRH Store \(3\)](#)

[MRH Store \(4\)](#)

[NCE \(2 page spread\)](#)

[North American Railcar Co.](#)

[Pre-Size Model Specialities](#)

[Precision Design Co.](#)

[Rapido \(1\)](#)

[Rapido \(2\)](#)

[Ring Engineering \(1\)](#)

[Ring Engineering \(2\)](#)

[Rulers-of-the-World](#)

[Rusty Stumps](#)

[Scale Trains](#)

[Scotty Mason Show](#)

[Sea Port Model Works](#)

[Soundtraxx \(Blackstone\)](#)

[Southern Digital](#)

[Streamlined Backshop Services](#)

Clickable advertiser index – 2

[TAM Industries](#)

[TAM Valley Depot](#)

[The DCC Shop](#)

[Tony's Train Exchange](#)

[Trackside Flats](#)

[Train Control Systems](#)

[Traintek](#)

[TrainMasters TV \(1\)](#)

[TrainMasters TV \(2\)](#)

[TrainMasters TV \(3\)](#)

[TrainMasters TV \(4\)](#)

[TSG Multimedia](#)

[Walthers](#)

[Westerfield Models](#)

[Yankee Dabbler](#)

[Yarmouth Model Works](#)

Clickable "other" index

[Other – Contents](#)

[Other – Cover](#)

[Other – Derailments](#)

[Other – Hobby Marketplace](#)

[Other – MRH Sponsors](#)

DOWNLOAD ISSUE



DOWNLOAD PORTRAIT



DOWNLOAD LANDSCAPE

• INDEX



SUBSCRIBE
(free)

• TABLE OF CONTENTS



REVERSE RUNNING

commentary

JOE FUGATE
.....



[Click here for
reader comments](#)

IS IT TIME FOR DEAD RAIL TO DIE?

ON MY NEW SISKIYOU LINE 2, I WANT TO TAKE ADVANTAGE



of the latest hobby developments, which includes considering things like battery power for my locomotives.

Because I am using The “**One Module**” Approach (TOMA) for my new home layout, even the very first module section I’m building needs to be completely done and fully operational.

This is forcing me to plan all aspects of my layout right from the get go. One important aspect of that planning is making sure I get fully operational layout signals even on the first module.

As I think about possibly using so-called “dead rail,” I’m realizing how inaccurate and confusing a term “dead rail” is. As I dig deeper, I’m realizing the whole concept of unpowered rails and no wiring

▶ **STEPPING OUTSIDE THE BOX WITH A CONTRARY VIEW**

to the track just isn't an accurate characterization of battery power, especially in anything smaller than G scale. It's a "hype" term.

Reality is, if you want *practical* battery power for O scale and smaller, you likely want power to the rails on much of the layout.

The cleanest way to recharge your batteries is through trickle charging via the rails. Taking my locos apart to charge the battery is a non-starter. So is finding some place to "disguise" a charging socket on the loco. I don't want to handle my locos to keep them running.

Yes, there's all the wireless recharging hype starting to surface now, but most of it is close field charging, meaning you need to set the object to charge right on the charger. If true long-distance wireless charging does come to model railroading, you will still need a large sensor pad on your loco somewhere – and how will you disguise it?

When it comes to signaling, the most realistic signaling comes by using detection that determines if a current is flowing from rail to rail, just like the prototype does. That way, I can put resistance wheelsets on my rolling stock (two per car) and any car parked on signaled trackage will trigger the signal as well as the locos.

But that means power to the rails as well.

Sure, I don't want the bother of powering frogs or places on crossings where rails cross each other. That's fine. With battery power in my locos, I can just leave these short problem areas unpowered. But for trickle charging and signaling, I need the rails to be powered for the most part.

So the term "dead rail" needs to go. It's generally not the best idea to have totally dead rails *everywhere*. A much better term is "**Power-On-Board**", or POB. It's not about the track – it's about *how your locos get their power*. Batteries are power-on-board.

The term POB much more accurately describes what's going on without the hype. I still plan to solder feeders to the rails of my track on Siskiyou Line 2. Dead rail it's not, even with batteries.

It's time to lay "dead rail" to rest and move to POB instead.





DERAILMENTS



A boy after our own heart ...

While I was working as a store Santa, a boy asked me for an electric train set. “If you get your train,” I told him, “your dad is going to want to play with it too. Is that all right?”

The boy became very quiet. So, moving the conversation along, I asked, “What else would you like Santa to bring you?”

He promptly replied, “Another train.” ■

► BIZARRE FACTS AND HUMOR (SUPPOSEDLY)

OFF THE RAILS ...



💰 GET PAID ...

If you're the first to submit a bit of good humor or bizarre facts and we use it, it's worth \$25! Just send to derailments@mrhmag.com ■

Prototype for everything

Here is a unique solution for those of you who have a column in your layout room and you can't figure out how to get your track plan to fit ... just do what the prototype did!

Coming next issue ...

- Upgrading an Athearn Ready-to-Roll SD40.
- Multi-tool layout building tips for model railroaders
- ABS layout signaling
- Model a scale track
- Building the Glen Green module
- And lots, *lots* more!



[Click here to rate or comment on this article](#)

HAVING FUN WITH TRAINS
JANUARY 2018 | FREE

MRH

MODEL RAILROAD HOBBYIST

ALSO:

- Model a scale track
- Multi-tool tips model railroaders
- ABS layout signaling
- Rolling stock selective compression
- Building the Glen Green module
- ... and more inside!

Alex Reed
Upgrading an Athearn R-T-R SD40 ▶ **READ NOW**

CP Rail
6406

