

HAVING FUN WITH TRAINS

OCTOBER 2018 | FREE

# MRH

MODEL RAILROAD HOBBYIST

## ALSO:

- Signaling your layout
- NMRA National in KC report
- First time resin casting
- Naming trains and switches

*... and more inside!*

## Les Green

# Breathes new life into Blue Box locos by installing DCC and LED lights

▶ **READ NOW**



LANDSCAPE EDITION



DOWNLOAD



REGISTER  
*(free)*

• [INDEX](#)

• [TABLE OF CONTENTS](#)

Now Available from



**ATLAS N, HO, & O SCALE HANDCRAFTED LIGHTS**



**CLICK HERE!**

FOR MORE INFORMATION OR TO LOCATE A DEALER, PLEASE VISIT [WWW.ATLASRR.COM](http://WWW.ATLASRR.COM).  
ATLAS MODEL RAILROAD CO., INC. • 378 Florence Ave., Hillside, NJ 07205



Model Railroad Hobbyist | October 2018 | #104

(Updated 09/28/18)



ISSN 2152-7423

**Editorial Staff**



Joe D. Fugate, Publisher and Editor

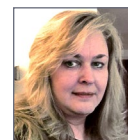

Patty Fugate, Pasteup and Layout



Richard Bale, News and events



Jeff Shultz, News and events, Tech Assistant



Joe Brugger, Copy Editing



Mike Dodd, Copy Editing

**Advertising**

Les Halmos, Account Manager  
Daniel Nava, Advertising Assistant  
Jean-François Delisle, Marketing Assistant

**Columnists**

Larry Smith, Narrow Gauge/Shortlines  
Ken Patterson, Reporter at large

**Rotating Columnists**

Jack Burgess, Getting Real column  
Nick Muff, Getting Real column  
Mike Rose, Getting Real column  
Tony Thompson, Getting Real column

Rob Clark, Imagineering  
Dave Meek, Imagineering  
Ray Dunakin, Imagineering

Issue password: Oct2018

Published for the glory of God. [What's this?](#)





# MRH SPONSORS



Model Railroad Hobbyist | October 2018 | #104

## A - D



[acculites.com](http://acculites.com)



[railroadhobbyshow.com](http://railroadhobbyshow.com)



[archertransfers.com](http://archertransfers.com)



[athearn.com](http://athearn.com)

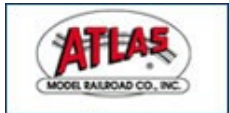

[www.atlasrr.com](http://www.atlasrr.com)



[bachmanntrains.com](http://bachmanntrains.com)



[backdropjunction.com](http://backdropjunction.com)

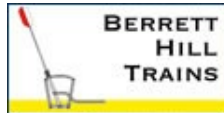

[berretthill.com/trains](http://berretthill.com/trains)



[blairline.com](http://blairline.com)



[bowser-trains.com](http://bowser-trains.com)



[mycaboose.com](http://mycaboose.com)



[coffmaneng.com](http://coffmaneng.com)



[\(youtube channel\)](https://www.youtube.com/channel/UC...)



[www.digitrax.com](http://www.digitrax.com)



[decalprof.com](http://decalprof.com)

## MRH SPONSORS | 2

## E - R



[trackplanning.com](http://trackplanning.com)



[esu.eu/en](http://esu.eu/en)



[modelrailroadexpo.com](http://modelrailroadexpo.com)



[handlaidtrack.com](http://handlaidtrack.com)

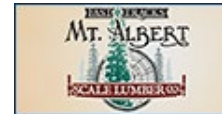

[handlaidtrack.com/mt-albert-scale-lumber](http://handlaidtrack.com/mt-albert-scale-lumber)



[iascaled.com](http://iascaled.com)



[lights4models.com](http://lights4models.com)



[litchfieldstation.com](http://litchfieldstation.com)



[micro-trains.com](http://micro-trains.com)



[store.mrhmag.com](http://store.mrhmag.com)



[ncedcc.com](http://ncedcc.com)



[www.pwrs.ca/main.php](http://www.pwrs.ca/main.php)



[rapidotrains.com](http://rapidotrains.com)



[ringengineering.com](http://ringengineering.com)

When talking to hobby vendors, please remember to mention MRH.

[Vendors: Get your clickable logo here ...](#)

[Vendors: Get your clickable logo here ...](#)



MRH SPONSORS | 3

S - Z



[scaletrains.com](http://scaletrains.com)



[soundtraxx.com](http://soundtraxx.com)



[sodigi.com](http://sodigi.com)



[sbs4dcc.com](http://sbs4dcc.com)



[tamvalleydepot.com](http://tamvalleydepot.com)



[traintekllc.com](http://traintekllc.com)



[walters.com](http://walters.com)



[yankeedabblers.com](http://yankeedabblers.com)

[Vendors: Get your clickable logo here ...](#)

Looking for something? Check the MRH Marketplace!

Take me there!



**STREAMLINED K4 WILL WOW YOU**  
**DCC WOUNDSOUND®-EQUIPPED K4 4-6-2 PACIFIC**

New to Bachmann's *Spectrum*® line, our Streamlined K4 4-6-2 will make you say "wow." This DCC sound-equipped model includes a TCS WOWSound® CD-quality 16-bit 44,100Hz decoder with Audio Assist® for easy configuration without programming CVs as well as a Keep-Alive® device for uninterrupted operation, even over dirty track. It features a WOWSound® steam locomotive sound package that includes bell, whistle, blow down, cylinder cocks, water fill, coupler close/release, brake release and application, momentum, grade crossing quill, departing and arriving station announcements, and more. Get wowed: visit your favorite hobby dealer to see the Streamlined K4 today!

Features include:

- DCC sound-equipped for sound, speed, direction, and lighting control
- true CD quality audio in 16-bit 44,100Hz sound
- Keep-Alive® device that keeps your engine running during power interruptions due to dirty track or loss of electrical contact
- voice-guided Audio Assist® programming tool for easy set-up of almost all decoder functionality
- dual-mode NMRA-compliant decoder
- precision motor

- operating headlight
- all metal chassis
- blackened metal wheels and siderods
- die-cast trailing truck
- painted engineer and fireman figures
- metal cut levers
- separately applied parts including pump, handrails, grabirons and tender ladder
- E-Z Mate® Mark II couplers, front and rear

PRR #1120 Item No. 85301

PRR #3678 Item No. 85303

PRR #5338 Item No. 85304

Click to learn more

SHIPPING FALL MSRP \$469.00 each

DCC SOUND ON BOARD

BACHMANN QUALITY SINCE 1953

Bachmann Industries, Inc. • 1400 East Erie Avenue • Philadelphia, PA 19124 USA • [www.bachmanntrains.com](http://www.bachmanntrains.com)

[Click for more information.](#)



# TABLE OF CONTENTS



Model Railroad Hobbyist | October 2018 | #104

## FEATURES



HO

### Adding DCC and LEDs to BB locos

LES GREEN



ALL SCALES

*Special Electrical Impulses series ...*

### Signaling my layout, part 1

JASON MILLER

Model railroad ABS system components

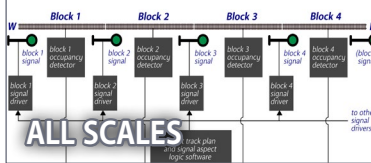

ALL SCALES

### Model RR signaling 101

JOE FUGATE



ALL SCALES

### First time resin casting

CHRIS ADAMS

## TABLE OF CONTENTS | 2

### COLUMNS

#### MRH Q-A-T

Compiled by JOE BRUGGER

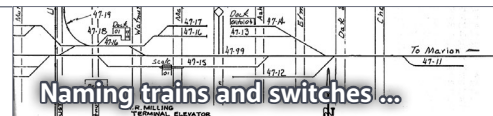

#### What's Neat

KEN PATTERSON



#### Yes, it's a model

Compiled by JOE FUGATE



#### Derailments

Compiled by the MRH Staff



### NEWS and EDITORIAL

#### Publisher's Musings

JOE FUGATE

#### News & Events

RICHARD BALE and JEFF SHULTZ

#### Reverse Running

JOE FUGATE

ALSO:

MRH Marketplace

Registered member extras



**PREORDER TODAY**

(Actual Models Shown)

DUE  
EARLY  
2019**Three All-New Versions****GE Tier 4 GEVo ET44****Preorder Now**

This product is made under trademark license from General Electric (GE).  
 © 2018 ScaleTrains.com, Inc. ScaleTrains.com, Rivet Counter, and  
 respective logos are trademarks of ScaleTrains.com, Inc.  
 ScaleTrains.com, Inc. 7598 Highway 411 Benton, TN 37307  
 844-9TRAINS 844-987-2467 International 423-299-3689

HO  
#87 SCALE

Scene and photography  
 by Ken J Johnson  
 First test model shown

MRHMAG.COM

REGISTER  
(free)**PUBLISHER'S  
MUSINGS**

Model Railroad Hobbyist | October 2018 | #104

RATE THIS ARTICLE

**JOE FUGATE:** THE GREAT CAR WEIGHT  
 DEBATE ... AND SPINNING OFF THE NEW  
 RUNNING EXTRA MAGAZINE

**IN RECENT YEARS, I'VE SEEN A NUMBER OF**  
 debates online about car weighting. The focus of the discussion  
 revolves around the NMRA car weighting guidelines, RP 20.1. If  
 you're not familiar with these guidelines, you can find a copy on the  
 NMRA website:

[nmra.org/sites/default/files/standards/sandrp/pdf/rp-20.1.pdf](http://nmra.org/sites/default/files/standards/sandrp/pdf/rp-20.1.pdf)

Some feel that because the car weighting recommendations of the  
 NMRA were made in the 1950s, they're now out-of-date and cars now  
 don't need that much weight.

In my new book, [Make it run like a Dream: Rolling Stock](#), I devote an  
 entire chapter to this topic of car weight. I examine all viewpoints.

I show that a case can be made for weighting cars less than the  
 NMRA standards if you're concerned about pulling capacity. In fact,  
 the European (NEM) or Australian (AMRA) car weighting standards  
 make the cars lighter than the NMRA weight recommendation.

One thing I notice is the NEM/AMRA standards are linear – the weight  
 per inch is constant. The NMRA standards make the cars lighter per  
 inch as they get longer. If you're going to overweight cars more than the  
 NMRA recommendation, using the NMRA amount plus two ounces

• INDEX

• TABLE OF CONTENTS



# PUBLISHER'S MUSINGS | 2

makes the weight per inch less as cars get longer. See this chart from my book comparing the various weighting formulas for HO:

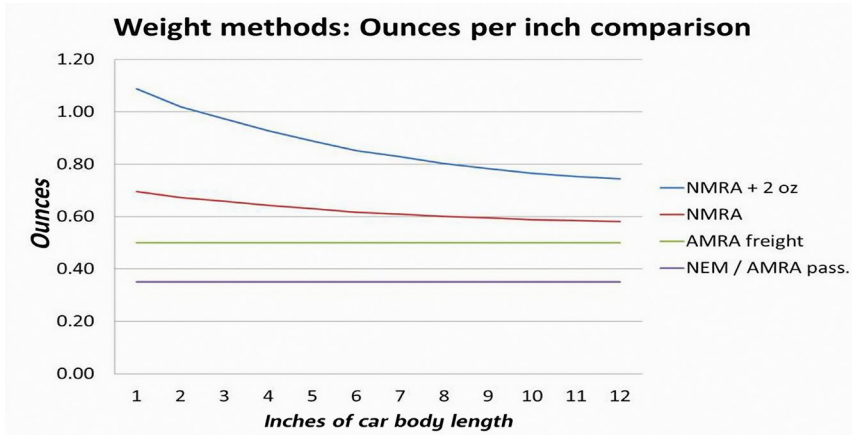

1. Weight methods chart from *Run like a Dream: Rolling Stock*.

ADVERTISEMENT



## GO WITH THE CENTERFLOW

THE ULTIMATE ACF 4600 3-BAY CENTERFLOW HOPPER IS NOW IN ATHEARN GENESIS

**ANNOUNCING** The 3-bay CenterFlow covered hopper first entered service in the mid-1960s built by American Car and Foundry. The cars handle loads such as grain, corn and similar bulk commodities. The Centerflow relies on the car's rounded body to provide structural strength without the added weight of bracing, as well as making gravity unloading easier. This 3-bay car came in a 4,600-cubic foot capacity. The railroads looking to replace

their aging 40' box cars in grain service needed a modern hopper design. One that could operate within the tighter Plate B clearances for light branchline and industrial service. ACF's design won them many contracts from a plethora of railroads. One can find these cars still in revenue service today in grain trains and other similar service. Athearn is excited to announce the brand new ACF 4600 cubic foot 3-Bay CenterFlow hopper exquisitely detailed in Genesis HO and in N-scale.



Early high side ladder and high brake wheel version depicted

- Early (High side ladder and brake wheel), Mid (low brake wheel), and Late/Post 1971 body variants
- Round or trough hatches
- Photo-etched metal roof walk
- Separately applied wire grab irons and stirrup steps
- Separate brake cylinder, valve and air reservoir with wire brake plumbing
- Detailed outlets
- Multiple road numbers
- Fully-assembled and ready-to-run out of the box
- Accurately painted and printed
- Highly detailed, injection molded body
- Separately applied brake wheel
- Genesis 100-ton trucks with 36" machined metal wheels and animated spinning roller bearing caps
- Screw mounted trucks
- Body mounted McHenry operating scale knuckle couplers
- Weighted for trouble-free operation

VISIT [ATHEARN.COM](http://ATHEARN.COM) FOR PRICING AND COMPLETE SELECTION OF ROADNAMES!

ADVERTISEMENT

Making changes should be easy!

**SoftTrak<sup>®</sup>**

Flexible track with optimized geometry between track ends, with or without easements or S-curves. Ignore the details - design faster, design better!

See how Denny designed a steel mill in a month!

[Click here!](#)

**3rd Plant 3D CAD**  
The ultimate track planning software

**El Dorado SOFTWARE**



MICRO-  
TRAINS®  
LINE

COMING JANUARY 2019

N  
SCALE 1:160

TTX

Well Car 16-Packs



#993 01 760 ... 'Clean' 16-Car Pack ... \$399.95



#993 01 765 ... 'Weathered' 16-Car Pack ... \$449.95

CLICK HERE FOR MORE INFO

## PUBLISHER'S MUSINGS | 3

One can make a pretty good case for weighting cars less than the NMRA recommendation these days. Advocates of weighting cars at less than the NMRA recommended practice argue that it's more efficient to have lighter weight cars. But then along come some radicals like Mike Confalone who advocate deliberately overweighting your cars!

So who is right – the underweighting advocates or the overweighting ones? Here's what I say in my book:

Having experienced one of Mike Confalone's all-day Allagash operating sessions first hand, I have to admit, the difference from overweighting is quite interesting. The trains just feel more massive when you run them. There is a subtle but compelling sense of weight to these "tiny" trains.

I like to think of overweighting this way: we deliberately do things such as selective compression to fudge our models for our

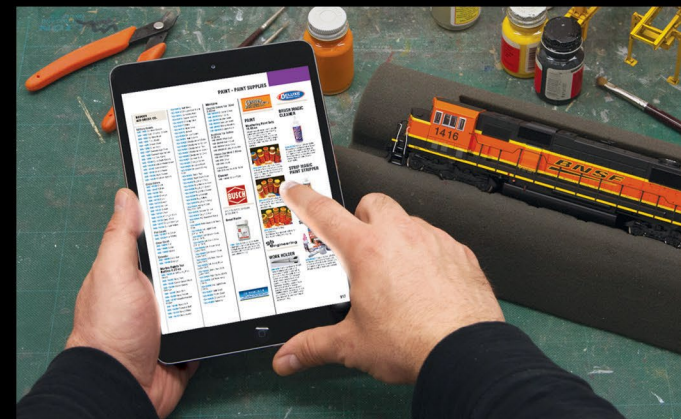
Whether  
it's time  
to browse...or time  
to buy...

we've got you covered.

*Everything you need to build a great model railroad!*

## 2019 HO-N-Z Reference Book

Available in two formats -  
Print and the **all-new digital edition!***Click here to reserve yours today!*NEW  
DIGITAL  
EDITION!

WALTHERS

Support your local hobby shop • visit [walthers.com](http://walthers.com) • call 1-800-4-TRAINS

© 2018 Wm. K. Walthers, Inc.

MRHMAG.COM

REGISTER  
(free)

• INDEX

• TABLE OF CONTENTS



## PUBLISHER'S MUSINGS | 4

miniature world. On the model, few of us run 100-car trains on our layouts, yet we like running two, three, or even four diesels on the head end of our much shorter trains.

Why not selectively compress the mass of that 100-car train to fit our much shorter trains? Why not make those short trains really need all that power to get over the road? It makes a certain kind of sense, actually.

True, if we were paying the bills for moving those cars over the railroad, we would want lighter cars, of course.

If making our trains feel more massive by overweighting the cars happens to make things “less efficient,” then so what?

A key tenet of getting our model trains to run like a dream is pursuing a richer operating experience, not to win a medal for simply making things more efficient. Efficiency is laudable in our day job, but fun is the most important goal of a hobby.

This all said, remember I am a diesel era modeler of a railroad that liked to run long heavy trains and long diesel lashups to go with them.

I do know the one major problem with model steamers is they often can't pull a prototypic number of cars. In that case, going with the lighter weight standard probably makes more sense. But if you model the diesel era with long head-end lashups, you might want to give overweighting a try.

So I can see both sides, and depending on what you're after, both underweighting and overweighting are viable. For me, I prefer overweighting and I use +2 oz. on the NMRA weight in HO.

[In my book](#), I discuss car weighting for all the scales from Z to G – and provide guidelines for both sensible underweighting and sensible overweighting.

Some HO overweighting advocates say they simply use one ounce per inch. Yes, that's easy to remember, but I think it's overkill on longer cars.

ADVERTISEMENT

Full SP light package

Accurate lost wax brass SP horn

Correct hood and roof profiles 3D scanned from the prototype

SP roof-mounted water tank

HO SCALE SP VERSION

CLICK HERE

Rapido's innovative dead straight metal side handrails w/ plastic stanchions

FIRST PRE-PRODUCTION SAMPLES SHOWN!

Roadname-specific corner steps

ALCO RS-11

PRR inductive trainphone antenna

Rapido TRAINS INC.

PRR cab signal box

Roadname-specific air filter configuration

Operating headlights, number boards & green/white class lights

Check out all that etched brass!

PRR VERSION

ORDER DEADLINE:  
November 19th, 2018





## PUBLISHER'S MUSINGS | 5

The NEM/AMRA have a lower weight standard for passenger cars (they tend to be longer of course), and in a similar fashion the NMRA recommendation also puts less weight per inch in longer cars. So the must be something to using less weight per inch in longer cars.

I use the carbody length *only* to determine the car length for weighting. The couplers don't count. Also, most 40-foot cars, for example, actually have a car body that's 42 feet, since the 40-foot length is an inner dimension. I call the "quoted" length the nominal length, and the true length the body length.

Here's what you end up with in HO using these different approaches and considering nominal vs. actual length [2].

Nominal length (ft)	Typical body length (ft)	Body length (in)	NMRA RP20.1 weight	AMRA Freight Weight	NEM weight	1 oz per inch overwt.	NMRA RP20.1 + 2 oz.
35	37	5.10	3.5	2.5	1.8	5.1	5.5
40	42	5.79	3.9	2.9	2.1	5.8	5.9
45	46	6.34	4.2	3.1	2.3	6.3	6.2
50	51	7.03	4.5	3.4	2.5	7.0	6.5
55	56	7.72	4.9	3.8	2.8	7.7	6.9
60	62	8.54	5.3	4.2	3.0	8.5	7.3
65	66	9.09	5.5	4.5	3.3	9.1	7.5
70	72	9.92	6.0	4.9	3.5	9.9	8.0
75	77	10.61	6.3	5.2	3.8	10.6	8.3
80	82	11.30	6.6	5.6	4.0	11.3	8.6
85	86	11.85	6.9	5.8	4.2	11.8	8.9
90	89	12.26	7.1	6.0	4.4	12.2	9.1

2. Weight strategy comparisons for HO. Adapted from my book *Make it run like a Dream: Rolling Stock*.

Notice for an 80-foot passenger car (body length 82 feet), I'm looking at cramming 11.3 oz into the car versus 8.6 oz, which is still a considerable amount, but a much easier task.



# Bowser

New  
Announcement!!

## HO 70 Ton 2 Bay Covered Hopper Cars

Ready to Run with added brake wheel, under frame, air tank, brake cylinder, triple valve, free rolling trucks with metal wheels and knuckle couplers.

\$25.95 each

Road Names:

Burlington,  
Cedar Heights Clay,  
Central Soya,  
D&H,  
DT&I,  
Erie Lackawanna,  
GTW,  
GN,  
Halliburton,  
International  
Minerals,  
Mathieson,  
Shippers Car Line,  
Southern,  
Union Carbide  
Linde,  
US Phosphoric  
Products,  
& XTRA Western  
Pacesetter

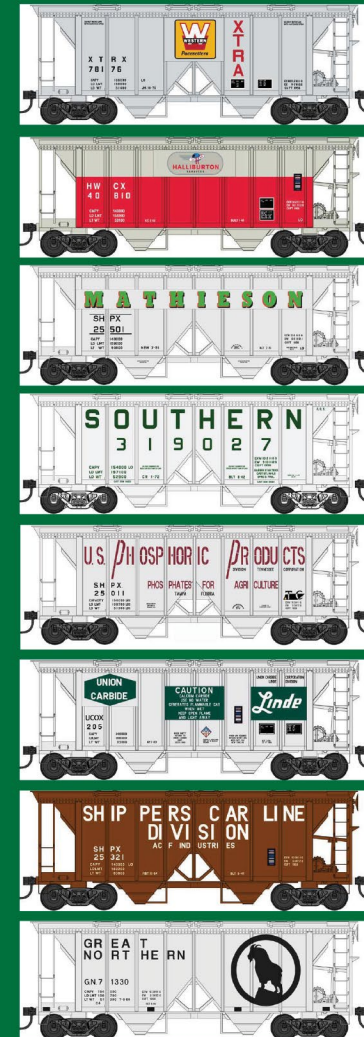
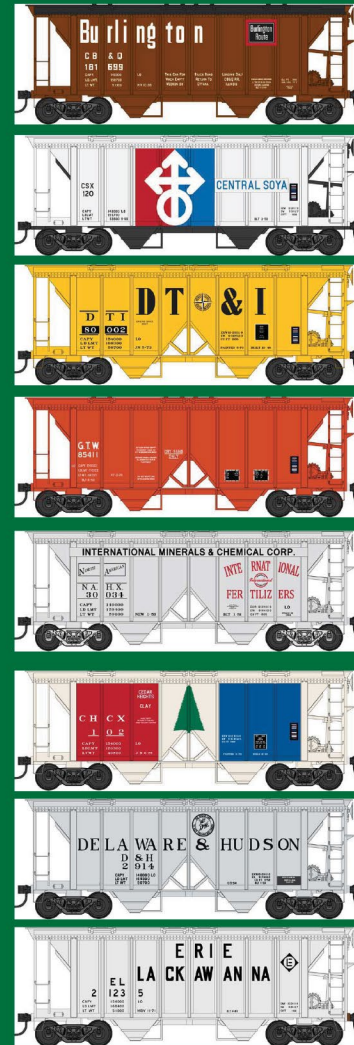

Click here to check out the details for these and other great Bowser Products



# CABOOSE™

Sharing Our Passion for Trains Since 1938



**CLICK HERE**  
for the  
**Serious Modeler's  
Resource!**

More than 148,721 items,  
over 567 manufacturers,  
**most at a discount from  
full retail – all at  
a fair price.**

**As always, in-stock orders of  
\$100.00 or more ship free  
within the Continental U.S.!**\*

\*surcharges may apply for oversize items.

**10800 West Alameda Ave.  
Lakewood, CO 80226  
(303) 777-6766**

## PUBLISHER'S MUSINGS | 6

At the low end, the NMRA weight + 2 oz. gives weights very similar to the 1 oz. per inch method for the 40 and 50 foot cars that are typical on my railroad.

Bottom line for me, I find the NMRA + 2 oz. method to be more practical than 1 oz. per inch, especially on longer cars.

Okay, once you've decided which weighting strategy to use, how do you get the weight in there? I give many different methods in my *Run like a Dream: Rolling Stock* book [3].

I discuss the method details and sources for all these weight approaches in my new book.

Researching and providing examples of each of these weighting methods took considerable time and effort, so I save you all that hassle and expense by putting it all at your fingertips under one cover.

And that's just one of nine chapters covering every topic you can imagine on how to get great performing rolling stock.

## PUBLISHER'S MUSINGS | 7

Weighting method	Cost / oz.	Oz / cubic in.	Notes
Pennies	\$0.10	4.2	Some may dislike "defacing" currency
Steel wheel weights	\$0.15	4.7	Magnetic, best for car interior only
Plaster	\$0.15	1.7	60% less dense than metal weights
Lead sheet	\$0.55	6.6	Average cost (varies by sheet thickness)
Lead weights	\$1.00	6.6	Pricy but convenient
Woods metal/Cerrobend	\$1.20	4.2	Low melting point metal w/cadmium (158F)
Tungsten powder*	\$3.37	4.3	Weight is average for putty made with powder
Fusible Bismuth	\$4.16	4.0	Very low melting point metal w/cadmium (117F)
Fields metal	\$20.80	3.9	Safe non-toxic low melting point metal (144F)

\*Tungsten powder is very dense (8.6 oz per cubic in), but must be mixed with some glue or plaster to make a putty; that reduces the density. The oz per cubic inches figure is an average for the putty.

**3. Weighting methods cost/weight comparison from my book *Make it run like a Dream: Rolling Stock*.**

[Run like a Dream: Rolling Stock](#) is \$11.99 for the eBook. If you prefer paperback, shipping is free in the US and outside the US shipping is half-price.

### MRH Premium Edition is now MRH *Running Extra*

We want to make it very clear we are not discontinuing the free *Model Railroad Hobbyist* magazine next month, we're just downsizing it to what the ads pay for. In fact, *this issue* has been downsized to within 50 pages of what the November MRH will be.

To avoid confusion, we want to make it clear the new larger paid magazine is a new product, separate and distinct from the free magazine. For that reason, we have retitled the new magazine MRH *Running Extra*. It will have its own unique cover and contain at least 150 pages of new material that's not in MRH.

The new magazine, MRH *Running Extra*, premieres in November and will be \$1.99 per monthly issue, or \$19.99 for an annual



# MRH CONTEST: "California Basement" Challenge

**\$1000 GRAND PRIZE • \$500 FIRST PRIZE  
\$250 - Honorable mentions (two chosen)**

**Goal: Design a layout for a one- or two-car garage  
(your choice). ENTRY DEADLINE: FEB 28, 2019**

**Two room-size  
choices:**

**Single car garage  
(14'x24')**

**Double car garage  
(24'x24')**

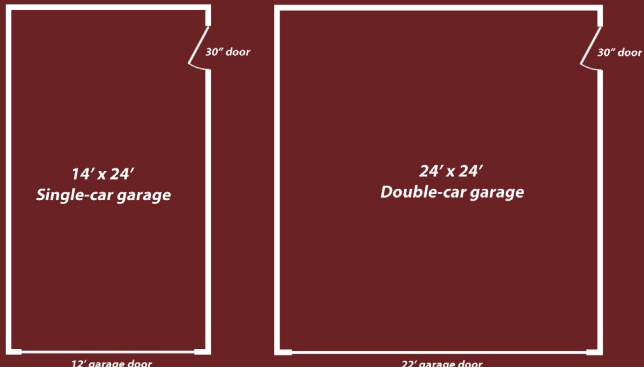

Note: This is a wide open home layout design contest using any design approach. This is not a modular-only contest like past contests.

## CONTEST RULES

- Scale: Z-G, standard or narrow gauge.
- Draw up a final track plan and write up the design to be published. Extra points awarded for a high quality track plan, text, illustrations, photos, and captions.
- Describe the layout theme, rationale, and era (if any).
- Outline the basic construction methods you would take if you were to build this design. Extra points awarded for innovative thinking.
- The car does not need to go into the garage. You can use the entire space. However, the garage door does need to remain functional, it cannot be sealed shut, so describe what you will do to deal with that need.
- Beyond that, pretty much anything goes. Have fun and let's come up with some interesting track plans for a garage.
- All submissions must be publishable. If the submission is not formatted to be ready for publication, it will be disqualified. Take the time to be complete, provide captions, and to describe things completely in your text. See the [MRH submission guidelines for more information](#).
- The best submissions will be published and paid for the article.

**SUBMIT ENTRY (Choose "Contest entry")**

MRHMAG.COM



REGISTER  
(free)

## PUBLISHER'S MUSINGS | 8

subscription. If you prefer to save 17% over the cost of individual issues and avoid the monthly hassle of buying individual issues, the annual subscription is a great way to go, and [you can sign up here](#).



**VIEW READER  
COMMENTS**  
*click here*

• [INDEX](#)

• [TABLE OF CONTENTS](#)



## ★ LAST ISSUE'S RATINGS

The five top-rated articles in the [September 2018 issue](#) of *Model Railroad Hobbyist* are:

- 4.7 Weathering and detailing CSX 7826
- 4.6 One Module Challenge - Second place winner
- 4.5 Getting Real: Yosemite Valley flat cars
- 4.4 Homage to Grand Central Terminal
- 4.3 The Southern Pacific in Northern CA

Issue overall: **4.2**

**Please rate the articles!** Click the reader comments button on each article and select the star rating you think each article deserves. Thanks! ■

Get the latest Model Railroading News, Tips, Reviews & Opinions

**CHECK IT OUT!**



Our iTunes feed has changed search for "Mike And Scotty Live" to receive the latest episodes!

[www.themodelrailroadpodcast.com](http://www.themodelrailroadpodcast.com)

Hosts:

Scott Mason: [www.scottymason.com](http://www.scottymason.com)

Mike Rose: [www.mrhobby.com](http://www.mrhobby.com)

Don't Miss our Monthly Interviews  
& Product Announcements

MRHMAG.COM



REGISTER  
(free)

Coming

# this November

## Announcing MRH Running Extra!

(Renamed from the MRH Premium Edition)

~350 pages, \$1.99 ea.  
1 year sub: \$19.99

All the free MRH content with ads plus another ~150 pages of ad-free in-depth articles and columns.

You can buy and download single issues or get a 12-issue subscription.

Subscribe to  
Running Extra

[click here](#)



**SPECIAL OFFER: SAVE \$10**



TrainMasters TV

\$49.99 - 1 yr

+



Running Extra

\$19.99 - 1 yr

Bought separately

~~\$69.98~~

Get BOTH for just  
\$59.98

[click here](#)

Get TMTV  
+Running Extra

• [INDEX](#)

• [TABLE OF CONTENTS](#)

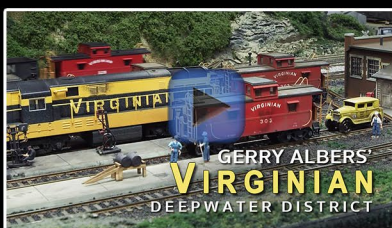
**TrainMasters TV: WHAT'S NEW!**Simple weathering  
with oilsCustomizing  
Tsunami steamMore live steam  
workshopGerry Albers'  
Virginian

"Every so often a project comes along that's a first rate idea combined with wonderful execution. TrainMasters is one of those ..." - D. Bott

CHECK IT  
OUT!Become a  
TMTV member**MRH ...  
QUESTIONS, ANSWERS, TIPS**

Model Railroad Hobbyist | October 2018 | #104

compiled by **JOE BRUGGER****Naming trains and switches**

**Q.** How are trains named? I'm getting ready to start laying out the different trains that will be running on my layout and I want to get the names right. Also, how are switches named or numbered in prototype practice? I will soon need to start labeling them and want to get it right. I am free-lancing based on the San Luis and Rio Grande and current Union Pacific/Burlington Northern Santa Fe practice would be good enough for what I am doing.

—T.A. Holmes

**A. Chris van Der Heide:** Depends on the railway. Some use letter symbols based on origin/destination. For example, a Houston-to-Los Angeles train could have something like "HOLA" and some use numbered symbols.

**David Husman:** The trains are usually named with a code for the type of train, a code for the origin station, a code for the destination station, and the date the train originated [1]. The UP and BNSF use

▶ **MRH QUESTIONS, ANSWERS, AND TIPS**



different codes for the types of trains. The UP uses two-character location codes and the BNSF uses three characters. There are also different modifiers for priority and sections.

**SPECIAL INSTRUCTIONS**  
BNSF Symbols 99

**Examples:**

C	EBM	PAP	092
Z	WSP	NBY	9 05
H	KCK	PAS	1 26
X	SWA	STE	8 14

**Sequence Number**  
Begins at 001 for the first train of the new calendar year. 092 would be the 92nd train of the year.  
Used with coal (C, E) trains and some unit (U) trains.

**Origin Date**  
**Section Number**  
**Destination**

**Origin**  
**Category**

<p><b>CATEGORIES:</b></p> <ul style="list-style-type: none"> <li>A Amtrak</li> <li>B Baretbles (Intermodal)</li> <li>C Loaded Unit Coal</li> <li>D Light Engines</li> <li>E Empty Unit Coal</li> <li>F Foreign Railroad Detour</li> <li>G Loaded Unit Grain</li> <li>H High Priority Merchandise</li> <li>I Deadhead Crew Move</li> <li>J High/Wide Move</li> <li>K Helper Service</li> <li>L Local Train</li> <li>M Regular Merchandise</li> <li>N Hours of Service Relief</li> <li>O Officer Special</li> <li>Q Guaranteed Service Intermodal</li> <li>R Roadswitcher</li> <li>S Intermodal Stacks</li> <li>T Transfer Service</li> <li>U Unit Train</li> <li>V Vehicles</li> <li>W Work Train</li> <li>X Empty Unit Grain</li> <li>Y Yard Job</li> <li>Z Priority UPS - LTL Intermodal</li> </ul>	<p><b>ORIGIN &amp; DESTINATION CODES:</b></p> <ul style="list-style-type: none"> <li>AAL Alma, WI</li> <li>ABA Alberta, MN</li> <li>ABE Aberdeen, SD</li> <li>ABI Abilene, KS</li> <li>ABK Abbyville, KS</li> <li>ABM Absaloka Mine, MT (Coal)</li> <li>ABN Albina, OR</li> <li>ABQ Albuquerque, NM</li> <li>ADR Adair, IL</li> <li>AGI Angiola, CA</li> <li>AGM Argyle, MN</li> <li>AGU Agudo, NM</li> <li>AKR Akron, CO</li> <li>ALA Albia, IA</li> <li>ALG Algoa, TX</li> <li>ALL Allouez Ore Dock, WI</li> <li>ALM Alma, WI (Coal)</li> <li>ALN Alliance, NE</li> <li>ALO Altus, OK</li> <li>ALP Alpena, SD</li> <li>ALT Alliance, TX</li> <li>AMA Amarillo, TX</li> <li>AMH Amarillo, TX (Coal)</li> <li>AMO Amory, MS</li> <li>AMS Amarillo South Yard, TX</li> <li>AMY Almyra, AR</li> <li>AND Alton, ND</li> <li>APP Appleton, MN</li> </ul>
--	--

1. The *Central West Timetable #1* published by Altamont Press in 2011 has detailed tables of train-naming information for Burlington Northern Santa Fe and for Union Pacific. It also includes employee timetable data, operating rules, signal aspects, and other railroad information.

UP locals and yard engines are symbolled differently than trains. Locals typically start with the letter L, then have a 3 or 4 character code for the territory or area over which they operate. Zone locals or traveling switch engines may start with a J. Yard engines start with a Y and the first character is typically the shift they work.

One caveat to all these naming conventions is that they depend on era. 1980 naming conventions are different from 1990 conventions as 2010 conventions as 2015 conventions. They change and evolve. The BN used to use two-character destination codes, and then after the merger changed to three-character codes. Different train categories were added and removed.

Switches? It varies. They are normally named for the track that is the diverging route or as the engineering department numbers them, but that's not used by the train crews. Tracks are numbered more than the switches themselves.

The SP track numbering system was called SPINS. The UP numbering system was called ZTS (zone-track-spot) and was different from the SPINS. ZTS uses a five-character station, a two-digit zone/yard number, a three-digit track number and a two-digit spot number. Tracks are numbered by function. For example, 700s are normally industry tracks, 200-to-400s are yard tracks, 1-99 are bowl or classification tracks.

Tracks are numbered by station, so the same yard and track numbers are used over and over at the different stations. Virtually every station on the UP has a 01-100-00 track (yard 1, track 100, no spot) which is the main track through the yard.



J. Brugger

**SWITCH NUMBERS:**

Switch stand targets on the Union Pacific were often stenciled with a track number, such as 47-12 in [2].



# MRH Q-A-T | 4

If you search for "Union Pacific ZTS" you can find those too.

**Joe Brugger:** If the above seems like too much complication, you could develop your own simplified system based on either

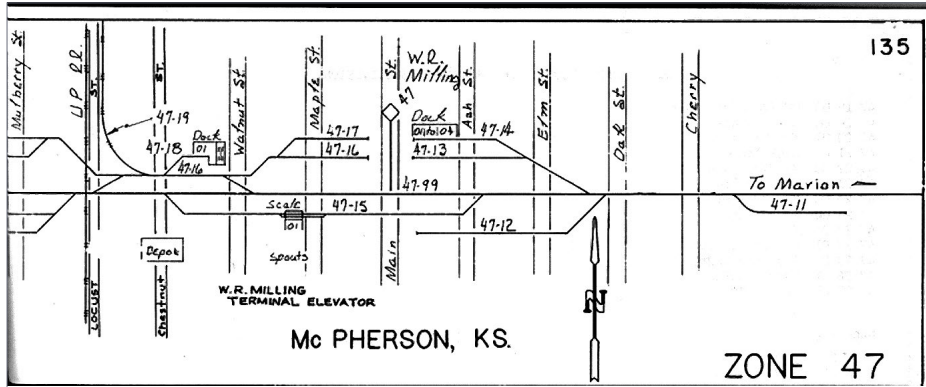

## ZONE 47 (MCPHERSON 59200) MCPHERSON SUBDIVISION

- 47 11 00 Goertz Track
- 47 12 00 Industry Spur
- 47 13 00 W R Milling South Track
- 47 14 00 W R Milling North Track
- 47 14 01 W R Milling (Dock) thru 04
- 47 15 00 W R Milling Term. Track
- 47 15 01 W R Milling Term. Elev. (Spout)
- 47 16 00 South Extension
- 47 17 00 Feed Track
- 47 18 00 Dock Track
- 47 18 01 AT&SF TOFC/Team (Dock)
- 47 19 00 UP Transfer Track
- 47 99 00 Main Line

PAGE 134

2, 3. Track segments are often named according to zone, track, and spot. "Zone 47" is a cluster of industrial tracks in McPherson, KS. Each track and each spot are identified so crews know where to spot and pull freight cars. The information is contained in a "CLIC" or "SPIN" booklet. Other railroads used different names for these documents. *Illustrations from Ken Glover collection*

ADVERTISEMENT

Build stuff like this?

**Subscribe**

Daniel Cortopassi Productions

ADVERTISEMENT

Make **REAL** Dry Transfer Graphics

... in less than 10 minutes!

**Color White Metallic**

**DECALPRO** *fx*

(850) 926-2009 (9-5 MST)

ADVERTISEMENT

**Backdrop Junction**  
Your Stop for Railroad Backdrops

**Click Here** →

**For the Finest in Custom Designed backdrop**

[www.backdropjunction.com](http://www.backdropjunction.com)

ADVERTISEMENT

**Archer**  
FINE TRANSFERS  
PROUDLY SERVING MODEL BUILDERS SINCE 1989

THE ORIGINAL **SURFACE DETAILS™**

WE NOW HAVE MORE THAN 130 SHEETS OF RIVETS, LOUVERS, TREADPLATE, WELD SEAMS AND MORE CAST ONTO MICROSCALE CLEAR DECAL FILM

**LOW SHIPPING:**  
DOMESTIC USA ORDERS \$2.80  
INTERNATIONAL ORDERS \$9.95

CLICK HERE TO VISIT OUR WEBSITE!

Archer Fine Transfers • PO Box 1277 • Youngsville, NC 27596 • USA (919) 570-1026 • info@archertransfers.com • archertransfers.com



BNSF or UP practices. You will want to identify the category (type of train), origin, and destination.

In many cases, a local can be identified by the letter “L” and a job number, so an out and back switching turn could be known simply as L39. The UP naming system uses “special condition codes” that indicate day of origination (1-7 for Monday through Sunday), X for unscheduled, P for perishables, and so on.

If you are running a general merchandise train, all your code needs to show is “M” for manifest, followed by the starting and ending points, such as an MPDNP, for a Portland OR to North Platte NE train.

**Prof Klyzlr:** For UP and BNSF train movements in and around Los Angeles, a copy of *“Southern California Locals: A Railroad Enthusiast’s Field Guide to Local Trains in Southern California”* by Charles Freericks gives a good overview of what runs where, and why the codes for that area are the way they are.

For the track and turnout numbering, search for “fog chart,” “Southern Pacific SPINS,” and “Santa FE CLIC.” SPINS and CLIC are systems which UP and BNSF predecessors used to track the locations, names, numbers, and industry assignments of various tracks.

Fog charts are informal “field notes” documents commonly put together by train crews for ready reference. They often link up with the official designations but also add the local flavor names, landmarks, references, and “tricks of the road” for the specific operation of particular areas and trains. I’ve personally found the LA and WA/Oregon SPINS and fog charts to be engaging and enjoyable research reading.

See the ongoing discussion at [mrhmag.com/node/34173](http://mrhmag.com/node/34173).

“Long Combo Right Clamp”™



Quality Tools with Superior Versatility

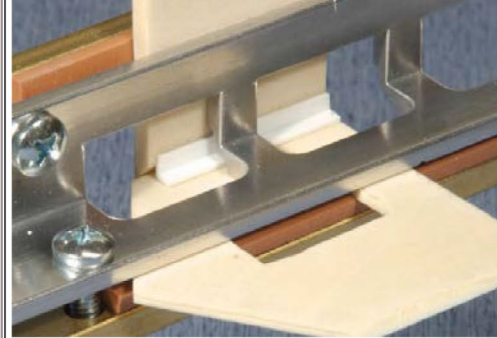

Essential Tools for Great Modeling

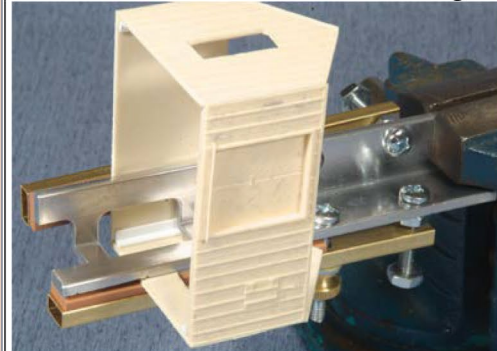

**Coffman Graphic Solutions**  
1500 River Circle, Richmond KY 40475

Click Here

Visit our new Website:  
[www.coffmaneng.com](http://www.coffmaneng.com)

LIGHTS4MODELS

LED's, Signs, and Sounds for All Scales

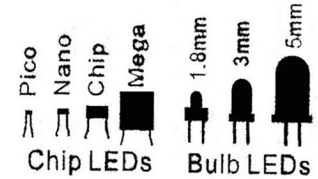

Miller Signs | Evan Designs  
Iron Penguin | Ring Engineering  
EZ Line | Tomar | ITT Sound Boards  
[www.lights4models.com](http://www.lights4models.com) 614-296-8691

Lasercut structures. Highway, storefront and billboard signs.

Neat ag customer for your railroad:  
**Farmers Fertilizer Supply**



WHAT'S NEW?  
←

Established 1993...  
**Blair Line**

## Compensating for grades on curves

**Q.** I was looking for values for grade compensation for grade curves and didn't find much definitive. From a post on another forum, I was able to figure out the grade compensation seems to be  $2784/\text{SCALE} * \text{RADIUS}$  – that is, assuming it is in fact a linear calculation.

Can anyone confirm that this equation works?

—Walt P.

**A. Mark Pruitt:** I've never seen it expressed like that. I've always seen the calculation as:

$\text{CG} = \text{G} + 32/\text{R}$ , where  
 CG = Compensated Grade  
 G = Measured Grade  
 R = Radius of curve

According to what I've read, that was originally developed by John Allen, an HO scale modeler.



4. Trains roll smoothly up the helix on Mark Pruitt's former CB&Q in Wyoming layout.

Some years ago, I came across what was presented as an LDSIG-modified version, replacing the coefficient of 32 with 28, giving the total equation as:

$$\text{CG} = \text{G} + 28/\text{R}$$

This gives about a 14% reduction in the effect of the curve – not a very significant difference in the model railroading world.

Your radius term of  $2784/\text{scale} * \text{radius}$  calculates out to that same Allen  $32/\text{R}$  term for HO. If your term is accurate and linear, then for N scale that works out to  $17.4/\text{R}$ . I am not at all convinced of the linearity of this

term across scales but have no data to either support or refute the claim. But if true (and linear), that IS a significant difference. Also, it does seem to make some sense that scale would have an impact.

In any case, the  $\text{G}+28/\text{R}$  worked well enough for me (an HO modeler also). I did my layout planning with it, and this performed as expected [4].

**Don Mitchell:** The operative wording, which I got from John Allen and the group that developed the formula, is: "Equivalent grade is defined as grade on curved track which would present the same resistance to a train on an actual grade of the same % on straight track. It is computed for HO scale using car weights equivalent to NMRA Recommended Practice 20.1 (1 ounce + 1/2 ounce per inch of car length) and car trucks of good quality from various manufacturers. The trucks are not of the 'super free-rolling' type."



J. Brugger

### GRADES:

"Grade compensation" is reducing the steepness of a grade on a curve to offset the additional rolling resistance caused by the curvature of the rails.





Note that the 32/R formula was derived from tests run over 50 years ago. The LDSIG formula of 28/R may be more representative of current wheel/truck production. Somehow, though, I have missed reading about how this was derived. As others have mentioned, the difference may be insignificant.

In practice, it's generally been more of a case of building the grade and curve to fit the space available, then adding engines or subtracting cars as necessary to move the train over the track.

Share your experience, in the thread at [mrhmag.com/node/32479](http://mrhmag.com/node/32479).

 TIPS

Finger saver



5. The hefty handle on a wall paper knife makes a single edge razor blade easier to control and saves wear and tear on the fingers. *Dennis Snyder photo*

ago, but I see the new ones by Zinsser on eBay with soft “comfort” handles for only \$7.99 with free shipping.

To make sharp, thin cuts, I prefer using single-edge razor blades. The only problem with them is that prolonged cutting and pressing down on that thin metal back tends to hurt your forefinger.

After some wallpapering sessions several years ago, I converted my wallpaper knife into a modeling knife. Now I have the great precision cutting ability of a single-edge razor and the comfort of a nice handle. I bought mine years

—Dennis Snyder

 GET PAID FOR YOUR TIP

We pay \$25 per tip we publish, or \$40 each if the tip also includes a photo or finished drawing.

[Click here and select article type TIP.](#) ■

VIEW READER COMMENTS

*click here*

ADVERTISEMENT

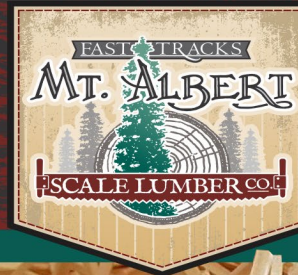

**BULK CROSS TIES**  
5,000 AND 10,000 QUANTITIES  
10% and 15% discount

MT. ALBERT PRODUCT LINE IS NOW AVAILABLE ONLINE!



Specializing in manufacturing fine scale lumber for model makers.  
Easy ordering • Live online support • Earn Waypoints with every purchase

shop online 24/7  
1-888-252-3895

handlaidtrack.com  
service@fast-tracks.net



# From first train set to railroad empire...

*Our complete line of DCC products grows with you. Discover the fun!*

- Designed and manufactured in the U.S.A.
- Preferred for ease of use and ergonomic design
- Unlimited scalability for any size model railroad
- Plug-and-play means more time running trains
- Great customer service and excellent support



## Visit our new and improved web site for all your DCC needs!

- Get the latest new product announcements
- Watch our detailed how-to videos
- Browse the all-new Information Station
- Enjoy secure online sales, day or night!



See your dealer

Visit [ncedcc.com](http://ncedcc.com)





Specializing in DCC! ~ The Best for Less! ~ Sales-Services-Installation!



## YANKEE DABBLER SPECIALS

Broadway Limited (SCALE=HO)  
Challenger 4-6-6-4  
Union Pacific UP **\$425.00**

Broadway Limited (SCALE=HO)  
SP Cab Forward 4-8-8-2 AC4  
Southern Pacific SP **\$325.00**

ATLAS 168-100 ATLAS 3' Code 100 Flex Track  
Box of 100 Pieces (HO Scale) **\$315.00**

NCE OLD MSRP SAVINGS

TCS WOW SOUND

ESU LOK SOUND

SOUNDTRAXX TSUNAMI 2 V 1.2

DIESEL LOCOMOTIVES



# ELECTRICAL IMPULSES

column



Model Railroad Hobbyist | October 2018 | #104

**JASON MILLER** WALKS US  
THROUGH DOING A LAYOUT  
SIGNAL SYSTEM IN PART 1 OF  
THIS THREE-PART COLUMN  
SERIES ...



**ONE OF THE “GIVENS” FOR MY LAYOUT IS THAT** I've always wanted signaling to help direct the movement of trains. When I first looked into what was needed, I was just a little shocked and quite overwhelmed. There is a *huge* amount of information to sift through and take in!

What type of signal system do I want to use? Do I follow prototypical North American systems like CTC, APB, or ABS? Do I use prototypical signal heads and indications specific to the area I'm modeling?

It all seemed rather complex, and I got disillusioned very quickly with the mass of information to digest. I hadn't even gotten into the actual hardware or software I was going to use, let alone the type of signal head or brand.

▶ ALL-THINGS-ELECTRICAL FOR MODEL RAILROADING

## ELECTRICAL IMPULSES | 2

The full process of determining what particular signal system type, signal mast type, hardware, and software to use could each need a lengthy series of articles.

By no means is my signal system totally prototypical for the era or the area my layout resides in, but the layout isn't rigidly prototypical either. The railroads are prototypical, the era is somewhat prototypical, and the towns loosely follow those that existed.

*Also see the "Model Railroad Signaling 101" supplement at the end of this article to help you get a quick overview of what a layout signaling system entails.*

### My basic signal system

To somewhat simplify things, I will cut to the chase and explain what I did on my layout, give you some brief concepts on why I chose what I did, and show the planning involved, the hardware



1. Jason Miller found signaling adds a lot of new interest to his operating sessions. In this series of columns, Jason tells us just how he did it.



# Southern Digital

WWW.SODIGI.COM

Celebrating 25 Years of serving you !

## Go Wireless InfraRed Expanded Zephyr System



Everything you will need to run 2 DCC trains.



~~\$390.00~~ Value  
**\$310.00** Your Price  
**\$80.90** You Save



**DCC Conversions, Service & Support**

E-mail: [sales@sodigi.com](mailto:sales@sodigi.com) (770) 929-1888





## ELECTRICAL IMPULSES | 3

and software needed, along with how I installed them. Finally, I will touch on how I operate the system on my layout.

My layout uses an NCE PowerPro 5-amp DCC command system to run the trains, so it provides the power and DCC signal. I also have a standalone LocoNet to detect trains on the track and to operate the signals from a software program controlled by a computer – so the signaling here is based around Digitrax detection and signaling hardware. Other DCC systems may require different hardware and software for them to work properly with this signaling approach.

I used JMRI's PanelPro software to enter my track plan, block locations, signal locations, and to set up the signaling logic.

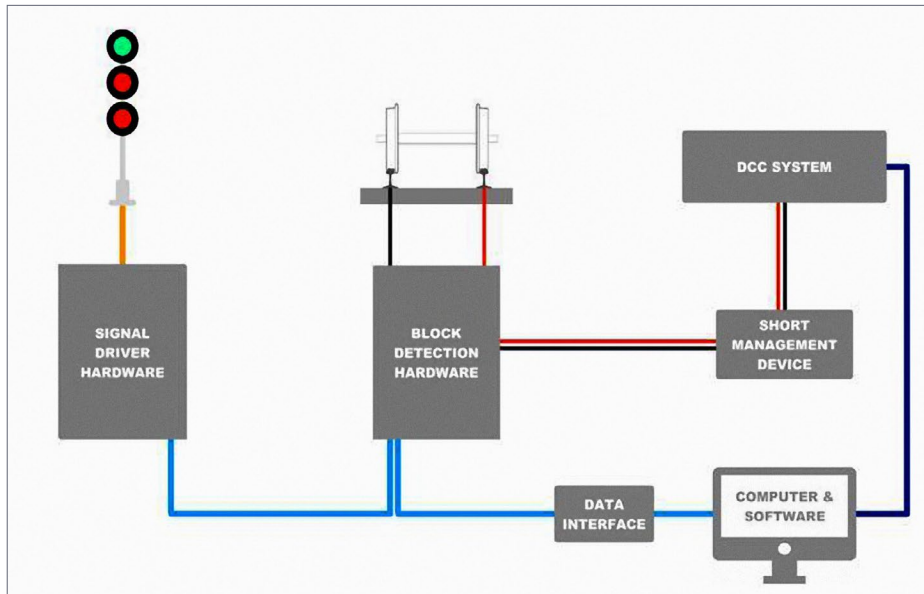

2. This diagram shows how the different parts of my signaling system relate to one another, and how they interconnect. Specific systems may vary.

Don't settle for all your locos sounding the same!  
ESU now has **OVER 100** "LokSound" files to choose from!

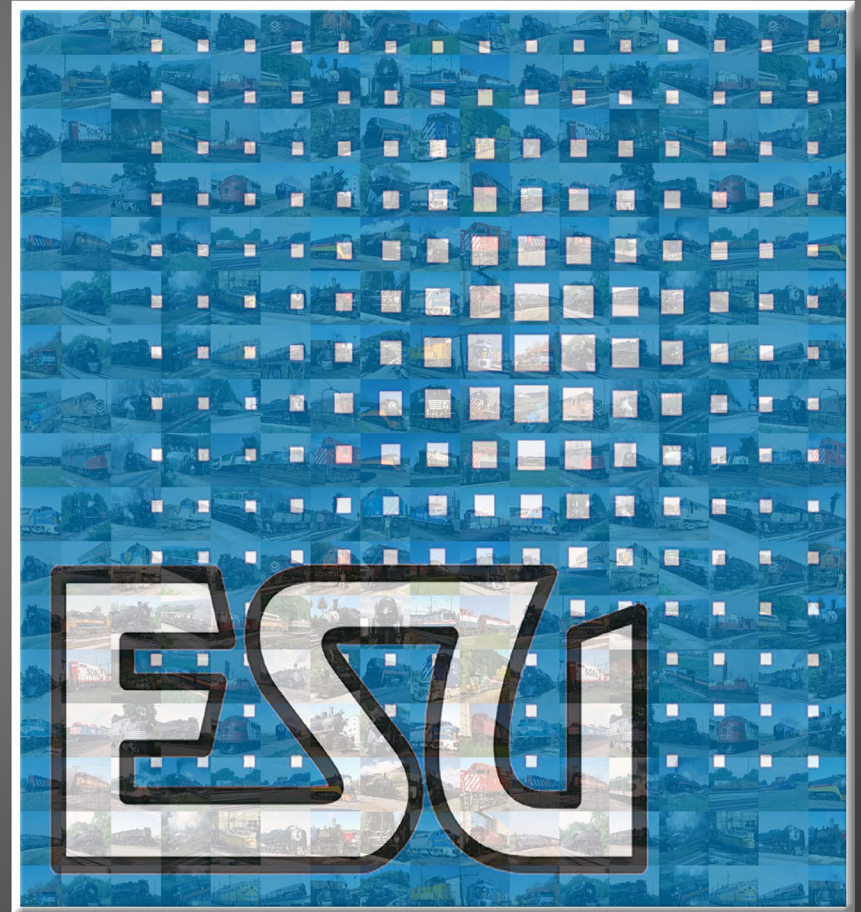

Because "Close Enough" is no longer "Good Enough"

LokSound.com



I drew up a simple block diagram to show all these parts and how they interconnect [2]. Let's dive into the details of how I planned my signal system.

**Definitions:** A signal "aspect" is the *appearance* of a signal, such as red, yellow, or green. A signal "indication" is the *information conveyed* by a signal aspect, such as Stop, Approach, or Proceed.

## PART 1 - PLANNING

### The signaling system

Planning began with determining the type of signal system I wanted to use. I chose the Automatic Block Signaling system for my layout.

### Getting up to speed on Automatic Block signaling

Automatic Block Signaling (ABS) divides the track into Blocks, which are sections protected by block signals.

Further definitions and useful explanation for signal systems can be found here:

[www.lundsten.dk/us\\_signaling/signalbasics](http://www.lundsten.dk/us_signaling/signalbasics)

I have used this link to educate myself about North American signal systems and I recommend it to anyone wanting to add signaling to their layout. It explains the different systems well and has helpful diagrams to show how they operate.

### The signal head

My next decision was what type or types of signal head I wanted. The Reading Lines and eventually Conrail used a variety of signal heads across the different states these railroads operated in.

They ranged from searchlights, triangular color lights, position lights, and color position lights. I based my decision to go with a

particular type on three key factors: cost, installation, and ease of interpreting the indication being displayed by the aspect.

For my layout, I chose the single-head searchlight type signal head, one section of G-type signal heads, and multiple double and single searchlight dwarf signals. I decided to stick with two manufacturers for the signal heads – Tomar and IHC.

My final decision came down to cost and the fact that Tomar offers triple-head, double-head, single-head mast signals, and single/double-head dwarf signals. I chose the IHC plastic kits due to the ease of making signal bridges with both searchlight and G-type heads if needed.

I did change the older style bi-color LEDs that come with the Tomar signals. I upgraded the Tomar and IHC plastic searchlight



3. I chose single-head searchlight signals, made by Tomar with upgraded LEDs from RRCirKits.



heads with RRCirKits tri-color LEDs. These have much truer rail-road signal colors.

Another consideration: what indication system do you want to use? Do you want a full prototypical system or will you simplify it somewhat based on a common theme that's easy for your crews to pick up?

The following information helped me gain an appreciation for signal heads, aspects, and indications for my chosen prototype:

[www.railroadsignals.us/signals/searchlights/index.htm](http://www.railroadsignals.us/signals/searchlights/index.htm)

### Blocks & detection

Blocks form the basis of a signaling system and are where it detects the presence, or occupancy, of a train (locomotive, rolling stock and/or caboose). The Digitrax - BDL168 occupancy detector boards I chose send this data to my layout PC via the LocoNet computer interface.



4. I also use dwarf signals by Tomar.



5, 6. I use IHC signal bridges.



<b>RULE 280a.</b>  Clear to next interlocking	<b>RULE 280b.</b>  Approach Clear	<b>RULE 281.</b>  Clear	<b>RULE 281b.</b>  Approach Limited	<b>CONRAIL</b> <b>SIGNAL ASPECTS</b> "LW" Indicates lunar white ⦿ Indicates flashing light ⊞ Indicates a number plate M October 1, 1988						
<b>RULE 281c.</b>  Limited Clear	<b>RULE 282.</b>  Approach Medium	<b>RULE 283.</b>  Medium Clear								
<b>RULE 284.</b>  Approach Slow	<b>RULE 285.</b>  Approach	<b>RULE 285a.</b>  Approach Restricting	<b>RULE 286.</b>  Medium Approach							
<b>RULE 287.</b>  Slow Clear	<b>RULE 288.</b>  Slow Approach	<b>RULE 290.</b>  Restricting								
<b>RULE 291.</b>  Stop and Proceed		<b>RULE 292.</b>  Stop Signal								
<b>RULE 293.</b>  Switch Closed Signal	<b>RULE 293a.</b>  Switch Open Signal	<b>RULE 294.</b>  Clear Slide Detector Signal	<b>RULE 294a.</b>  Slide Detector Signal	<b>RULE 295.</b>  Block-Limit	<b>RULE 295a.</b>  Approach Block-Limit	<b>RULE 296a.</b>  Approach Speed Limit Sign	<b>RULE 296b.</b>  Speed Limit Sign	<b>RULE 296c.</b>  Resume Speed Sign	<b>RULE 297.</b>  Approach Sign	<b>RULE 297a.</b>  Stop Sign

[click here](#)  
**THERE'S MORE!**  
Check out the registered member bonus extras

When talking to hobby vendors, please remember to mention MRH.

7. The signal indication system for my layout uses the NS (Norfolk Southern) 2008 – Signal Definitions that are part of the JMRI signal program. These are close to the Conrail 1988 – Signal Rules.



From this, the JMRI software determines the correct aspects needed and sends those via the LocoNet to the SE8C Signal Driver boards.

More information can be found on the Digitrax BDL1680 occupancy detector here:

[www.digitrax.com/products/detection-signaling/bdl168](http://www.digitrax.com/products/detection-signaling/bdl168)

You can find more information on the Digitrax SE8C signal decoder driver here:

[www.digitrax.com/products/detection-signaling/se8c](http://www.digitrax.com/products/detection-signaling/se8c)

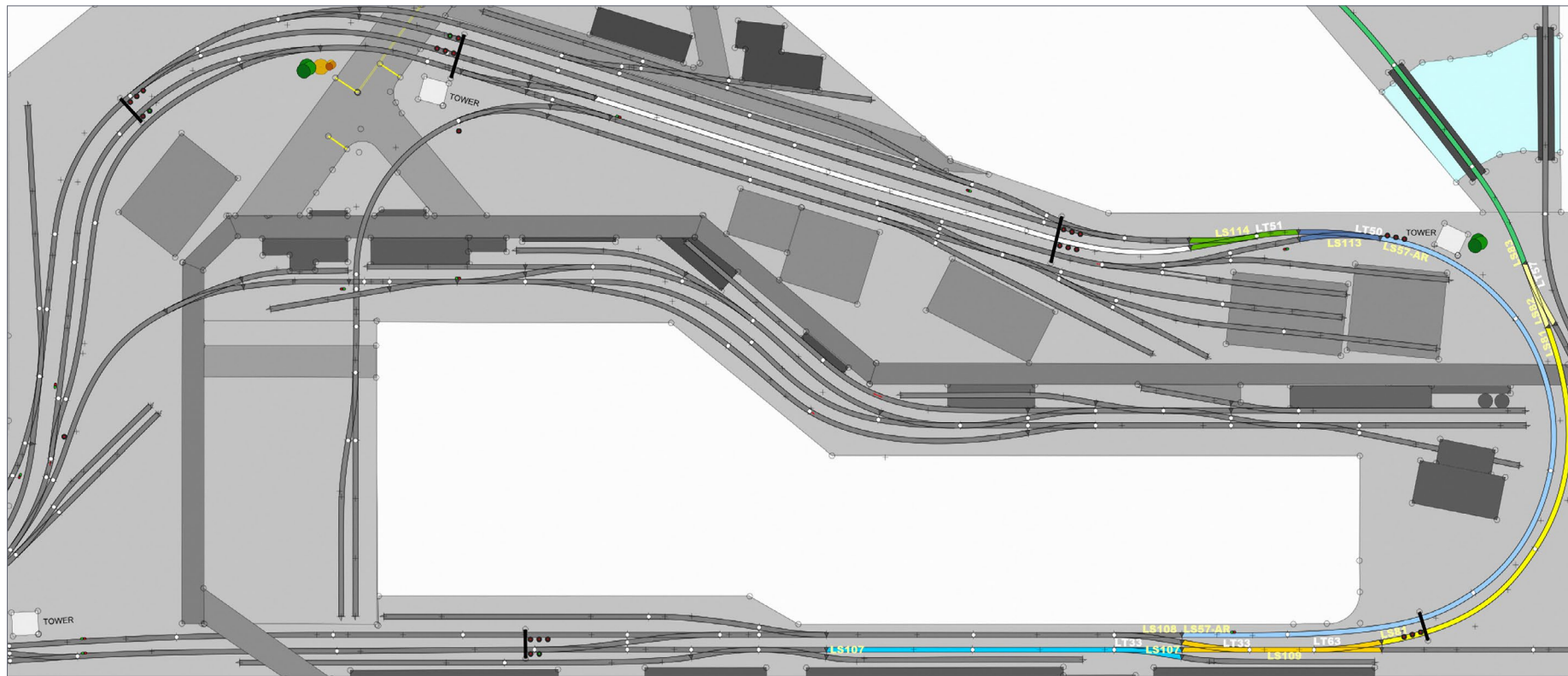

8. Examples of some block boundaries on part of my layout, highlighted in color.

Because I'm using Digitrax BDL168 occupancy detectors and Digitrax SE8C signal decoders, we will discuss how to plan for the detection and signaling using these boards only. There are many other different options and manufacturers to choose from to detect trains, but those are beyond my scope here.

## Digitrax-specific operation

Digitrax recommends what they call "Direct Home Wiring" for detection to function like a prototypical signaling system. This is the method I adopted, and the first step involves breaking up the layout into detection blocks.

My first question was “How big does a block need to be?” Many sources recommend blocks longer than the length of your average train, or the maximum-length train you ever expect to operate. This way the signal system will function like the prototype, even on our condensed model railroads.

To show some examples of block lengths, here is a section of my layout and some of the block lengths I’ve installed [8].

As can be seen in [8], block lengths can vary greatly. Short ones are used so a piece of rolling stock stored on a passing siding will alert the dispatcher to choose another route for a passing move if required.

Conversely, longer sidings like passing sidings can hold a 10-car local or small through freight easily. These blocks again could be divided into smaller blocks if required.

The only determining factor for breaking down longer blocks into smaller ones is cost, time, and programming. More blocks add the cost of additional detection boards, more insulated track joiners, more wire, more time to wire in the detection common wires for each section, and extra programming of the detection board in JMRI.

However, I learned a few things before breaking out the Dremel tool to cut gaps and rewire. For instance, when the JMRI PanelPro screen is displaying the occupancy of a section of track, unless you make interlockings – that is, junction points and critical routing turnouts – into separate blocks, these will show as occupied and limit traffic flow if they just form one big block with other trackage.

As an example, let’s take the situation in [9]. If train A in the top of the diagram diverged into the siding across the RH turnout and had to stop, and the rear portion was clear of the fouling point of the mainline turnout, you would expect train B to be able to proceed along the mainline track.

By making the turnout its own block for occupancy detection [9], the JMRI Panel in the bottom example would show the mainline (block 2 and block 1) as clear. If the turnout gets aligned to diverge, this allows train B to be given a clear aspect and to proceed along the mainline through the interlocking into block 1.

To accomplish the detection of a turnout and/or crossover, we need the ability to provide a power feed to the turnout’s frog and closure rails. On my layout, I use PECO Insulfrog code 83 turnouts, diamonds and slip switches. One of their great features

ADVERTISEMENT

**RailPro™** **NEW TECHNOLOGY** **RE RING ENGINEERING™**

**DCC + RADIO CONTROL**  
HO Scale Locomotive Module

**ULTIMATE SERIES SOUNDS** **TRUE MOTION TECHNOLOGY** **LIGHT EFFECT EDITOR** **DIRECT RADIO + NET™**

New Sound Technology and Mathematical Model Motion Control + more!!!

Equals "DUAL MODE" Control by DCC + Radio Control

**Click Here to Watch Video**

For more information visit our Internet site: [www.RingEngineering.com](http://www.RingEngineering.com)





is the ability to independently power the core of the turnout, and more importantly to increase the reliability of the power to all parts of the turnout when adding these extra power feeds.

I solder two feeders to connect *both* the stock rail and closure rail on both rail A and rail B. This ensures that power is fed to all parts of the turnout regardless of issues with the points not solidly contacting the stock rail.

Here is an example of how to wire a PECO Insulfrog Turnout for detection via power feeds [10].

By ensuring that junction turnouts and crossovers (either single or grouped together) are their own individual blocks, the detection system will be more efficient in detecting actual occupancy and ensuring better train flow over the layout.

Another important note about the placement of the Digitrax BDL168 boards: These need to be placed in a location that allows for the detection common feed to be run from the BDL168 to the track. The BDL168 cannot have a detection common wire

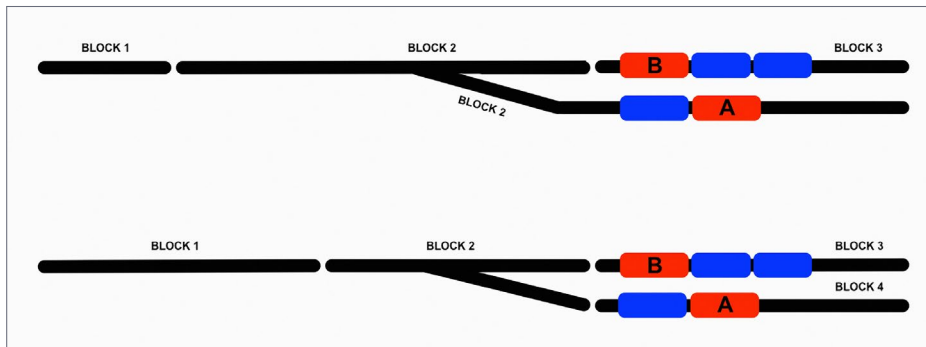

9. Here is an example of how breaking up junctions and turnouts into their own blocks helps streamline traffic flow. On the top diagram, train B is blocked by train A because the turnout is part of block 2. In the lower diagram, putting the turnout into its own block allows train B to move.

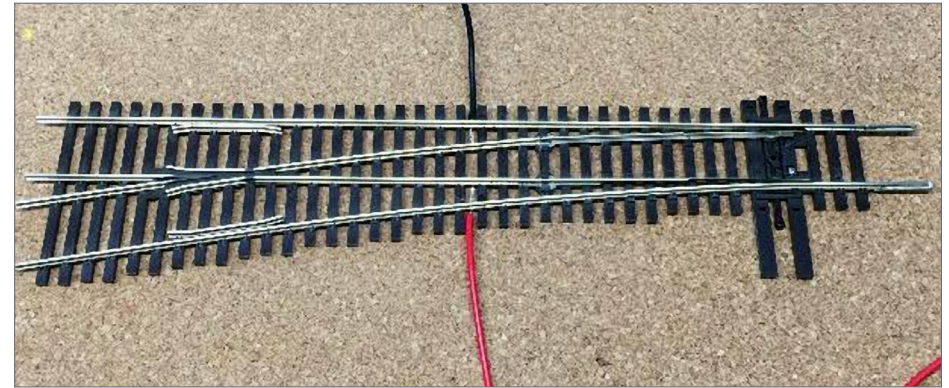

10. I solder feeders to the stock rails of my Insulfrog turnouts, and I also extend the feeders under the closure rails as well. This makes sure all parts of the turnout get power regardless of how well the points may contact the stock rails.

ADVERTISEMENT

[www.SBS4DCC.com](http://www.SBS4DCC.com)

Introducing the NEW  
**ZIMO MX660**  
Micro Sound Decoder

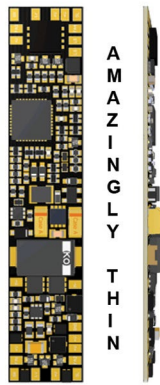

DELIBERATELY NARROW  
AMAZINGLY THIN

48 x 9.5 x 2.2mm

Available 2018

**N - HO - HO<sub>N3</sub> Scale Trains**

- 0.7 amp Continuous Current
- 6 Function Outputs w/ 1k ohm Resistors
- 1.1 watt, 8 ohm Amp
- Universal format with Large solder pads for easy connection
- Flat for easy mounting
- Full ZIMO Feature set

ADVERTISEMENT



Installing DCC sound just **NOT** your thing?  
Trust Traintek for sales and installation of sound decoders from these fine vendors!

ESTD 1984  
LOK SOUND

Digitrax  
RAILPRO  
DCC

SOUNDTRAXX  
SOUND

"Taking model railroad control to the next level..."

**Traintek**  
LLC.COM

[traintekllc.com](http://traintekllc.com)

Click here for more details...

"Traintek was the way to go!"

running to another power district, other than the one feeding the BDL168. The Power District should first feed power through a circuit breaker or combined circuit breaker/auto reverser in series, and then into the BDL168.

If you don't understand what this all means yet, just be aware the BDL168s need to be placed near their respective power district. We'll cover exact placement in more detail in part 2.

However, the Digitrax SE8C Signal Decoders do not need to be placed physically near the power districts. They are independent of these and the BDL168 boards, apart from being connected to the LocoNet for data transfer. The only real requirement is to

place them so that wiring runs to the signal driver boards and associated wiring are not excessively long.

When considering these factors, study the manufacturer's manuals for the detection system you are using. Resources like *Model Railroad Hobbyist*, [jmriusers@groups.io](mailto:jmriusers@groups.io), and other modelers who have installed signals are a fantastic resource! Remember, they have already broken the ground and walked the path where you are about to tread.

In the second part we will discuss these installation requirements more in depth with examples using wiring diagrams and photos from my actual installation.

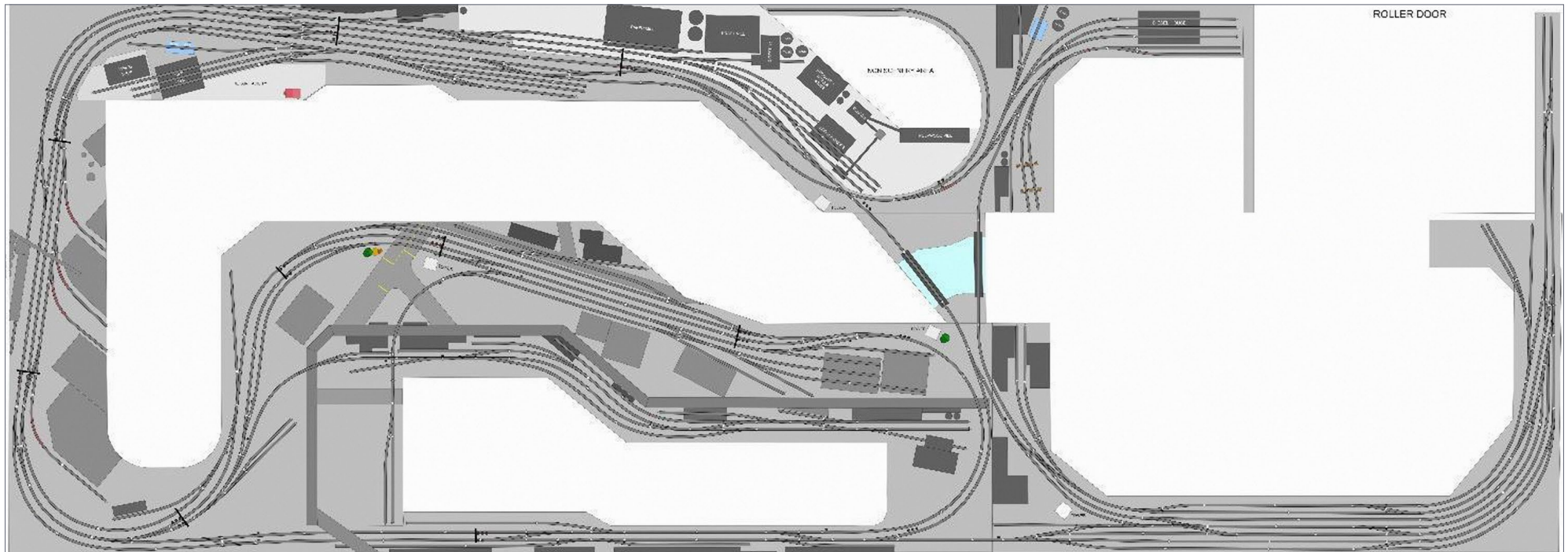

11. My layout with signaling block boundaries and signaling notes shown.



## Block and turnout plans

Developing a block and turnout plan is a good practice to ensure the installation is easy and that the blocks and wiring are in a good location. A good plan also makes it easier to find trouble spots later – and it can make changes later a lot easier.

I developed the block plan for my layout in AnyRail software, which is the same program used for my layout track plan [11].

The advantage of AnyRail is that it also has signal mast and dwarf symbols for the majority of commercial signals. I developed

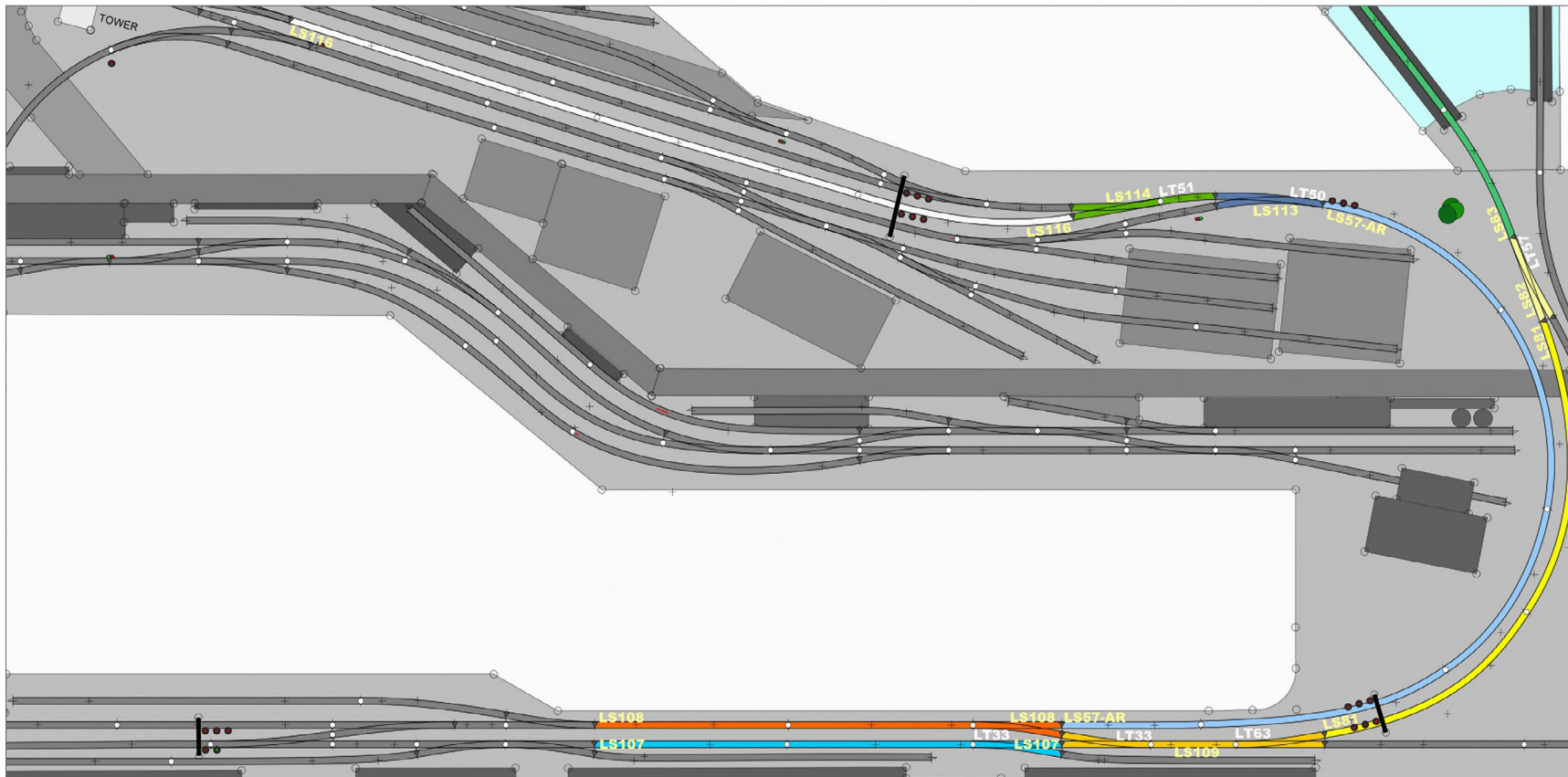

12. Closeup of my layout signaling track plan.

this plan to incorporate signal masts and dwarfs, and the switch machine locations.

The block boundaries are shown with the dark-colored triangles, and also are labeled either side with a common naming convention at the start and end of each block.

The importance of the common naming convention will be discussed when we look into the JMRI side of adding blocks, interlockings, signals, and the programming of the Digitrax SE8C and BDL168 boards.

BDL 168 Hookup worksheet					
Layout board number		<< Physical board number			
BDL168 Board Address # :		<< Digitrax board address			
Address :					
Description : Block detection for Augusta to Hackney					
Zone	Section	Pin #	Named Section	Description	Additional Power District info
Zone A	Power in	1	N/A	N/A	
		2	LSxx		
	Power District	3	LSxx		
		4	LSxx		
Zone B	Power in	6	N/A	N/A	
		7	LSxx		
	Power District	8	LSxx		
		9	LSxx		
Booster Common	N/A	11	N/A	Pin for connecting the booster common	
BDL power input	N/A	12	N/A	Pin for connecting board power to BDL168	
Zone C	Power in	13	N/A	N/A	
		14	LSxx		
	Power District	11	LSxx		
		12	LSxx		
Zone D	Power in	18	N/A	N/A	
		19	LSxx		
	Power District	15	LSxx		
		16	LSxx		

SE8C Board # 1										LED Driver boards	
Physical Board Location: Augusta / Udall										P2LEDs	P4LEDs
SE8C Signal Socket #	Signal location	Track / Direction	Red Indication wire colour	Green Indication wire colour	Panel Pro - Signal Mast Name	Panel Pro - Signal Head Name	Red / Green Switch #	Yellow / Dark Switch #	Signal LED info		
1			Black	Gray							
1			Blue	Yellow							
1			Brown	Orange							
1			Green	Violet							
2			Black	Gray							
2			Blue	Yellow							
2			Brown	Orange							
2			Green	Violet							
3			Black	Gray							
3			Blue	Yellow							
3			Brown	Orange							
3			Green	Violet							
4			Black	Gray							
4			Blue	Yellow							
4			Brown	Orange							
4			Green	Violet							
5			Black	Gray							
5			Blue	Yellow							
5			Brown	Orange							
5			Green	Violet							
6			Black	Gray							
6			Blue	Yellow							
6			Brown	Orange							
6			Green	Violet							
7			Black	Gray							
7			Blue	Yellow							
7			Brown	Orange							
7			Green	Violet							
8			Black	Gray							
8			Blue	Yellow							
8			Brown	Orange							
8			Green	Violet							

SE8C 10 pin plug wiring diagram		Looking down on the SE8C board pins				
Discription:	Not Used	LED 4 Green	LED 4 Red	LED 3 Green	LED 3 Red	
Wire Colour:	White	Violet	Green	Orange	Brown	
Pin #	9	7	5	3	1	
	0	0	0	0	0	
	0	0	0	0	0	
Pin #	10	8	6	4	2	
Wire Colour:	Black	Gray	Blue	Yellow	Red	
Discription:	LED 1 Red	LED 1 Green	LED 2 Red	LED 2 Green	Not Used	

[click here](#)

**THERE'S MORE!**

Check out the registered member bonus extras

**VIEW READER COMMENTS**

[click here](#)

These spreadsheets are in this month's bonus downloads!

13, 14. Spreadsheets I use as signal planning worksheets.



As can be seen in [12], there is quite a bit going on this space. It is approximately 10 x 6 feet (3m x 1.8m). The highlighted track sections contain:

- 10 detection blocks
- Seven slow-motion switch machines
- Three signal bridges
- One triple-head mast
- Two dwarf signals

When recording the location of blocks, signals, and turnouts, it helps to record the name, position, and hardware information on a worksheet.

I have been fortunate to be given a great example (derived from the Digitrax manual) by my good friend and detection and signaling guy, Brendan Dennis. Here are a couple of examples of worksheets to keep track of everything [13, 14].

Also remember that each searchlight signal head has a single LED. To get each searchlight signal to display one of the three aspects, each head needs three separate signal drivers from the board.

I used a spreadsheet to ensure I did not double-allocate an existing port on the SE8C [15]. This will also help when troubleshooting by providing a quick reference as to what has been programmed for each signal.

The importance of planning, recording, and sticking to a common and consistent naming standard cannot be emphasized enough!

### Direct Home Wiring

“Direct Home Wiring” is the term Digitrax uses for their recommended detection circuit wiring.

Note that these explanations only apply to the Digitrax BDL168 detection board. Other manufacturers may be similar or they

	A	B	C	D	E	F
	SIGNAL USERNAME	SE8C BOARD No	SE8C DRIVE No	DWF/MAST LT #'s	POSITION	ORIENTATION
1						A1,A2,B,C
2						
3	SHIPBTK1W-SB	2	1	321/322	UPP	A1
4				323/324	MID	A2
5				325/326	LWR	B
6	SHIPBTK3W-DWF	2	2	329/330	UPP	A1
7				331/332	LWR	A2
8	YHAVENTK5-INT-DWF	2	2	333/334	SINGLE	B
9	YHAVENTK3E-DWF	2	4	345/346	UPP	A1
10				347/348	LWR	A2
11	YORKTK4W-DWF	2	4	349/350	SINGLE	B
12	YHAVENTK5W-DWF	2	5	353/354	SINGLE	A1
13	SHIPBTK2W-DWF	2	6	361/362	UPP	A1
14				363/364	LWR	A2
15	SHIPBTK2E-DWF	2	7	369/370	UPP	A1
16				371/372	LWR	A2
17	SHIPBTK4E-DWF	2	7	373/374	SINGLE	B
18	HERSYTK1N	3	7	433/434	UPP	A1
19				435/436	MID	A2
20				437/438	LWR	B
21	HERSYTK3N-DWF	3	8	441/442	SINGLE	A1
22	S/SPRINGSTK1W-SB	4	3	465/466	UPP	A1
23				467/468	MID	A2
24				469/470	LWR	B
25			3	471/472	LWR	C
26	S/SPRINGSTK3W-SB	4	4	473/474	UPP	A1
27				475/476	MID	A2
28	RDGTK1W-DWF	4	5	481/482	SINGLE	A1
29	LEBNONTK3-DWF	4	5	483/484	SINGLE	A2
30	HBTK3W-DWF	6	4	601/602	UPP	A1

15. SE8C connection planning spreadsheet. You can get a copy of this spreadsheet [in this month's bonus downloads](#).

may differ. Obviously, studying the installation instructions for the specific detector is best.

Also keep in mind I use the NCE DCC system to operate my layout. I installed a standalone LocoNet specifically for use by my signaling.

# Real World Running!

*Dynamic Braking for the ultimate in realistic train operations.*



Diesel locomotives turn the electric traction motors into generators providing resistive electrical force to help slow the train. **Tsunami<sup>2</sup>** lets you replicate this with our interactive Dynamic Braking features.

## How our Dynamic Brakes work:

- **Dynamic Brake Low:** Dynamic Brake fans start up and the prime mover notches up.
- **Dynamic Brake High:** Dynamic Brake fans kick up to high and the train slows.
- **Release,** and your loco returns to normal operation.

With realistic features like this, it's no wonder serious modelers choose **Tsunami<sup>2</sup>**

www.soundtraxx.com

**SOUNDTRAXX**

## Make LocoNet wiring extremely simple!

**ACCU-LITES, inc**

Your DCC Center!

Dealer Inquiries Accepted

**PM42**  
breakout board



**SE8C**  
breakout board



**BDL168**  
Multi-zone  
breakout board

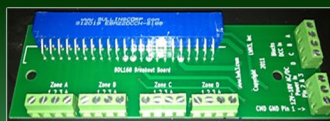

**BDL168**  
Single-zone  
breakout board



Now Offering SNAPS! in packs of 6 or 12 pieces! [CLICK TO LEARN MORE ...](#)



When detecting with a standalone LocoNet and the Digitrax BDL168 board, we depend on a voltage drop between the two rails. For powered locomotives and rolling stock using power (such as lighted cars), this happens automatically. For non-powered rolling stock, we need to put resistive wheelsets on the trucks to pass a tiny current so they get detected.

Only one rail (Rail A) needs to be broken into detection sections (four detection sections per “zone” on the BDL168) for a total of 16 detected sections per BDL168 board.

The other rail (Rail B) becomes the detection common return on the DCC booster power feed.

The BDL168 will send data via the LocoNet that the section of rail is occupied by a powered locomotive, powered car, lighted car, or rolling stock with resistive wheelsets.

The BDL168 occupancy data is sent to the layout PC (and the JMRI software) over LocoNet through an interface device. On my layout, I'm using a RRCirKits LocoBuffer-USB (For more, see [www.rr-cirkits.com/locobuffer-usb/LB-usb-flyer.pdf](http://www.rr-cirkits.com/locobuffer-usb/LB-usb-flyer.pdf)).

The received data is displayed on the JMRI PanelPro screen [16].



16a. Jason's entire layout displayed on his JMRI PanelPro screen.



Figure 1: Direct Home Wiring Example

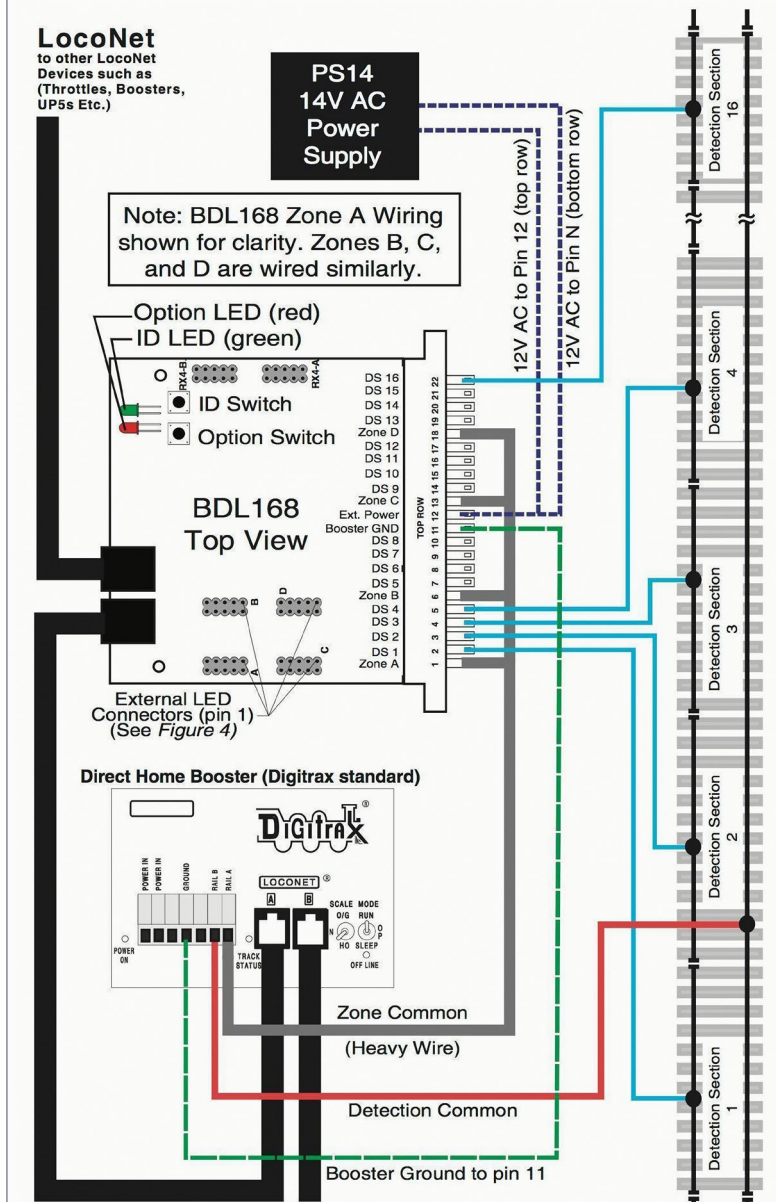

16b. Taken from the Digitrax BDL manual, this represents wiring using all Digitrax DCC system hardware.

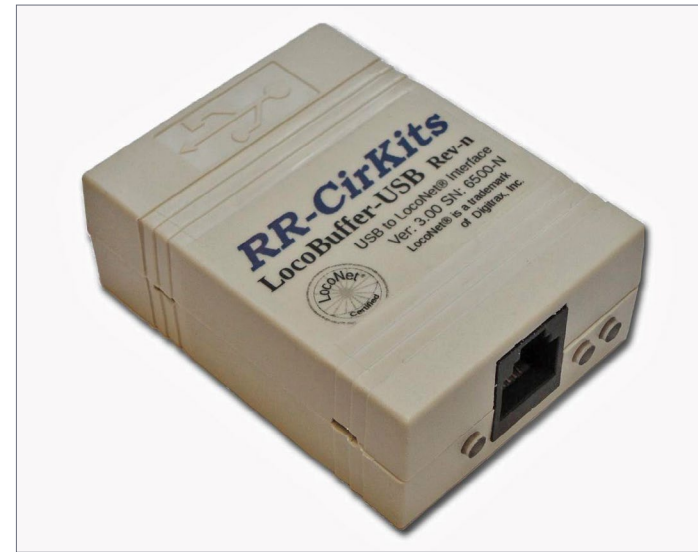

17. RR-CirKits LocoBuffer USB.

The detected rail needs to be consistent across the whole layout. On my layout, the rail closer to the fascia has been designated as the detected rail/Rail A.



J. Fugate

## REVERSING SECTIONS

When staying consistent with a given rail, watch out for reversing sections. A reversing section can cause Rail A to go from being closer to the fascia to becoming the rail farther from the fascia! One easy way to find this is to roll a railcar with contrasting sides around the layout – and if the side changes, you’ve found a reversing section.



Power districts and circuit protection

Before installing signals, we need to consider the power districts and wiring of the existing layout. If you start from scratch and allow for detected sections when wiring your layout, this will be less of an issue.

When I wired my layout, I used #1156 taillight bulbs for short-circuit protection. As technology advanced and the layout configuration changed over time, I upgraded the wiring to circuit breakers for short protection and I rewired the power districts to allow for detected sections.

I use one 5-amp booster for the entire layout. I have had no issues to date, but may once the final under-deck staging is installed. I may add an additional booster for Staging and Rutherford Yard when they are completed.

One issue that I have read about relates to circuit protection and the sudden inrush of current from sound-equipped locomotives when they start up. I have not encountered this yet, but it can be an issue that may cause electronic circuit breakers to trip.



J. Fugate

INRUSH CURRENT PROBLEM

In the early days of DCC sound, high startup inrush current was a problem and could cause boosters to shut down and short-protection circuit breakers to trip. Modern sound decoders and stay-alive circuits rarely have this problem. Most now include a resistor in the circuit to limit initial startup current so it's less likely to be a concern.

ADVERTISEMENT

END OF TRAIN DEVICE

NEW SAFETY GREEN



Bright Red Flashing Light!

Installs in minutes! No freight car modification required!

Patented Technology - US Patent 7,549,609

Does not affect Load!

Car without Load

Car with Load



Click Here to Learn More

RE RING ENGINEERING

ADVERTISEMENT

Discover the wonders of TrainMasters TV ...

FREE peek >>



TRAINMASTERS.TV

www.trainmasters.tv





## ELECTRICAL IMPULSES | 28

To ensure that this doesn't happen, you need to ensure that any circuit breakers or combination auto-reversers/circuit breakers have sufficiently high trip points or solid-state components to allow for this sudden inrush with sound-equipped locomotives.

I decided to install DCC Specialties circuit breakers and auto-reversers, as they have allowances for the inrush current caused by sound-equipped locomotives.

My layout has one NCE 5-amp booster. When I install the second 5-amp booster for the staging section, the layout will have two booster districts.

When I rewired the layout, I split my single booster district into eight new sub-power districts, each one individually short-protected. I wired each new power district with individual main bus wires from the command station and then fed them through the DCC Specialties PSX-1 and PSX-AR circuit breaker.

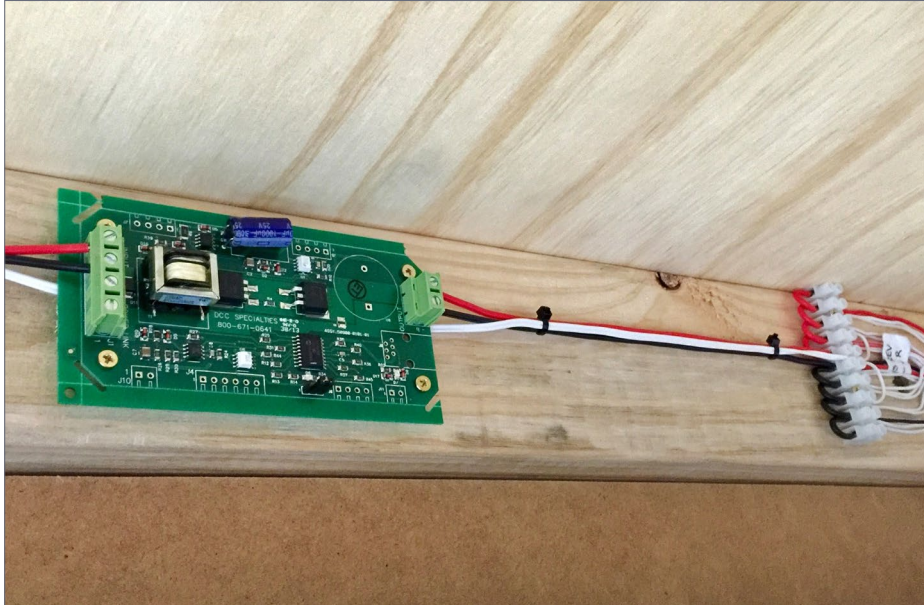

18. DCC Specialties PowerShield circuit breaker.

**WE  
HAVE  
PARTS!**

*Litchfield*  
STATION

**Check out our  
full line of Digitrax  
& NCE products  
at GREAT prices!**

**Lenz products  
ARE available!**



**Click here to visit our website:**

**[www.LitchfieldStation.com](http://www.LitchfieldStation.com)  
sales@litchfieldstation.com | 623-298-7355**



Here are my eight distinct power districts across the layout:

- North layout Pulp & Paper Mill, Classification Yard, Repair Facility.
- North-East layout Engine Service facility.
- West layout Hershey Chocolate Factory.
- South layout Rutherford, Hummelstown.
- East layout Rutherford Yard.
- Centre Peninsula North Harrisburg, Lebanon, Sinking Springs.
- Centre Peninsula South Reading, Pa
- Centre Peninsula Harrisburg to Rutherford (return loop) via PSX-AR (auto reverser).

So in total, the layout (when complete) will have two 5-amp NCE boosters and eight power districts. The boosters will be located near the layout PC ( for easy identification of issues and maintenance, and easy connections to JMRI) with individual feeds running to each PSX circuit breaker and then into a BDL168 near each location.

**Connections and interfacing to the NCE DCC system**

As mentioned earlier, my signal system is a standalone system, separate and distinct from my NCE DCC system. My standalone Digitrax LocoNet signal system operates the signals and provides occupancy detection to a software program on a computer.

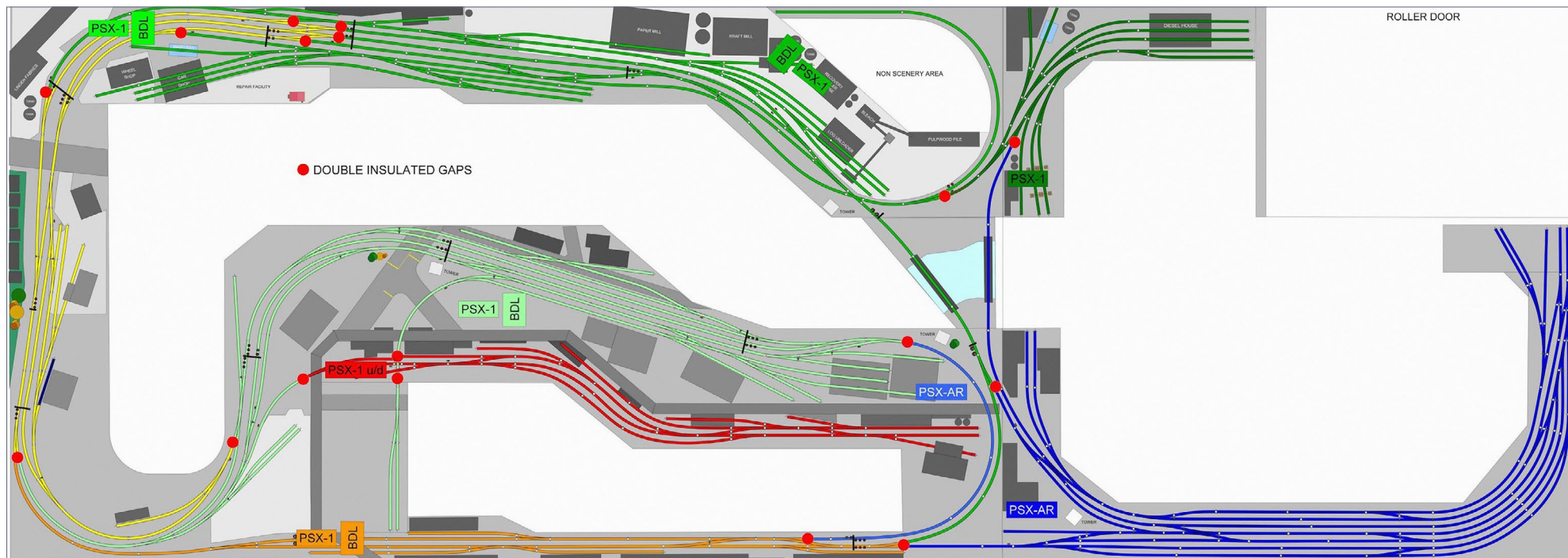

19. Power districts on my layout, with the detector and PSX circuit breaker locations shown.



Due to the way LocoNet works, and in particular the BDL168 boards, there is a requirement for the LocoNet and its signal outputs to interface with the DCC command station. To explain it without going into too much detail, the BDL168 requires a ground connection to the DCC command station for the BDL168 to be able to send occupancy data to the PC.

Without this ground (which is automatically in place if you're using a Digitrax command station, but not with an NCE system) the LocoNet and BDL168 can't send the data to the PC via the LocoNet.

To implement this ground connection, I created a pseudo ground with some electronic components connected to the DCC bus. There is also a connection required from the LocoNet cable to for the occupancy detection side to work too.

Figuring this out was the hardest part of doing a standalone LocoNet on a non-Digitrax layout. Even though others have done it and documented it somewhat, the required information to successfully set up a standalone LocoNet was not all in one place. It required some detective work to pull it together.

In Part 2 of this series, I will delve into installing these unique connections, including wiring diagrams and photos of the connections and the interface into the DCC main bus.

## Conclusion

As can be seen by the amount of information in in Part 1, you need to understand a considerable amount before diving into signaling system on your layout. And this is by no means the complete almanac!

Signaling a layout is a big task. Like everything in the hobby, there are many levels of complexity, and many choices to make.

## ACKNOWLEDGMENTS



I want to acknowledge the astonishing work on this project provided by my friend Brendan Dennis. Brendan has helped with much of the detection and signal planning and installation for my layout.

His knowledge on the subject has earned him the nickname of “The Doctor” within his circle of modelers, and the name truly fits. I would still be treading water with my installation if Brendan had not helped so freely.

So, Brendan, thank you for all your help to date and in the future!

It would also be remiss of me to not thank and acknowledge my other assistant electrical engineers, Noel and Dennis. They have spent many nights under the layout wiring up detection blocks, switch machines, and other electrical systems.

Detection and signals are a big undertaking, if you have friends or club members with experience, be sure you use their respective skills. It will save you hours, days, even weeks – and it's always good to share your build with friends. ■



Once you have the majority of the information at hand, and get some help from others that have been down this path before – it’s actually not that bad. It adds a new sense of prototype feel to a layout, and adds a whole new level of interest to operations.

And I must warn you, it’s addictive....

When thinking about my experience of installing my signal system, I like to remember the analogy, “*How do you eat an elephant?* Well, one mouthful at a time!”

Hopefully, this part of my series shows you where to start your research, how to develop a plan, and where to begin in implementing a signal system.

Please join me on the next part as we delve into the actual installation of the detection and signaling systems, get into connecting up the hardware and electronics, and look at interfacing with the computer and software.



20. It's *all clear* ahead!

## JASON MILLER



Jason lives in Diamond Creek, Victoria in Australia. He has been building his HO scale layout for the past eight years and attributes his start to his wife Linden, who said that he needed to get a hobby! What a wonderful wife....

Jason has been a professional firefighter for 15 years. When not at work he enjoys spending time with his family and working on the layout. Jason and Linden have two boys Lachlan, 11, and Toby, 7, who are both showing a keen interest in the hobby.

When not working on the layout and spending time with the family, Jason likes to work in the garden of the family home, and also enjoys having a coffee with the family at one of the local coffee shops.

The layout is HO scale and is based on the Reading Lines between the early to late '70s and the Conrail merger era. ■



*click here*

**THERE'S MORE!**

Check out the registered member bonus extras

**VIEW READER COMMENTS**

*click here*





# Special Supplement!



RATE THIS ARTICLE

**JOE FUGATE** teaches about model railroad signaling 101 ...

**TO GET A HANDLE ON WHAT'S NEEDED FOR MODEL** railroad signaling, it helps to first understand prototype railroad signaling.

To that end, let's look at the basics of prototype signaling, and then let's see how that translates into signaling on a model railroad.

## Prototype signaling

Real model railroad signals come in various flavors (ABS, interlocking, and CTC), but for this discussion we're going to look at the oldest and most common: automatic block signaling or ABS. The beauty of ABS is that the movement of the trains themselves automatically controls the signal aspects, hence the term *automatic*.

For ABS signals to work, the track is broken up with insulating gaps into train-length blocks. Here is a section of track broken up into four different train-length blocks with signals and no trains [1]:

Each rail combined with the block signal forms a complete low-voltage electrical circuit. Each block signal is wired to determine if the rail circuit is open, closed, or shorted. If the block is empty, that results in a closed circuit and the block signal displays green.

## Four ABS blocks, no train

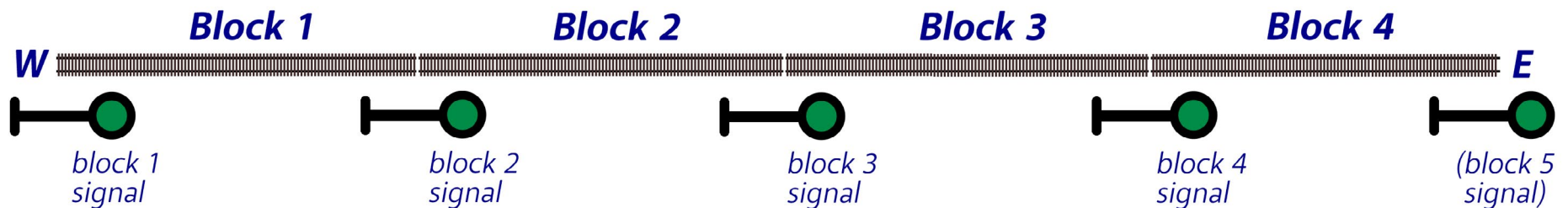

1. Four automatic block signaling blocks with eastbound signals and no trains. (For simplicity, the westbound signals on the other side of the tracks are not shown.)

NOTE: Block signal 5 is a placeholder shown without any block details.



When the conductive metal wheels of a railcar or locomotive enter the block, they short the track. The block signal interprets this short as a train or some other obstruction in the block, causing the block signal aspect to change color to indicate the block is obstructed.

If the rail breaks anywhere, that creates an open circuit, also causing the signal aspect to change color and indicate the block is not clear. Turnouts not aligned to the main also break the mainline rail flow and create an open circuit, also leading to a block not-clear condition.

Let's see how this all works in practice. If a train enters block 1, that shorts the rails and the block 1 signal goes to red [2]. Red tells an approaching train that the next block is occupied and it needs to stop.

## Four ABS blocks, eastbound train: block 1

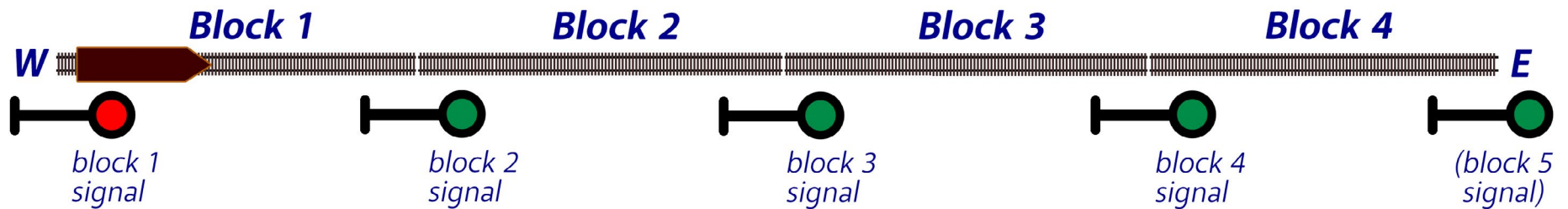

2. An eastbound train enters block 1 and the block 1 signal goes to red.

NOTE: Block signal 5 is a placeholder shown without any block details.

## Tell your friends about MRH!

We depend on word-of-mouth to grow  
... if you don't share us, we don't grow

**VIEW READER  
COMMENTS**

*click here*



As the train moves on into block 2, the block 2 signal goes to red, and the block 1 signal goes to yellow [3]. The yellow indication means the next block after this one is obstructed and the train needs to slow and be prepared to stop if the next signal is red.

## Four ABS blocks, eastbound train: block 2

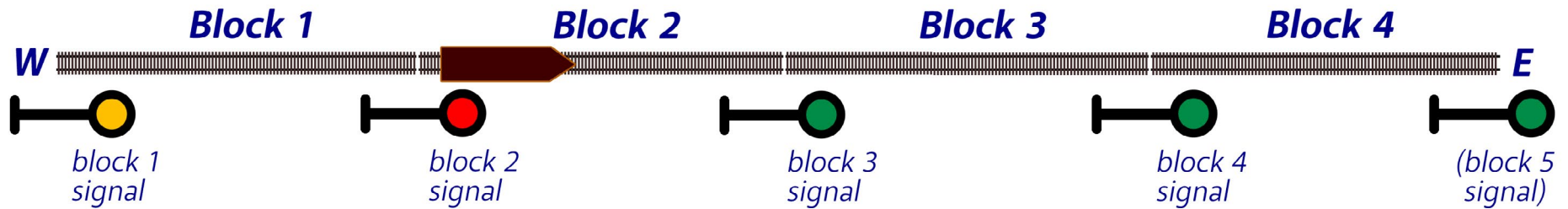

3. The eastbound train enters block 2, causing the block 2 signal to go red and the block 1 signal to go from red to yellow.

NOTE: Block signal 5 is a placeholder shown without any block details.

**Use our custom  
Google search on the  
MRH website to find  
topics of interest**

CLICK TO FIND OUT MORE

**VIEW READER  
COMMENTS**

*click here*

As the train moves into block 3, the block 3 signal goes red, block 2 goes from red to yellow, and block 1 goes from yellow back to green [4].

## Four ABS blocks, eastbound train: block 3

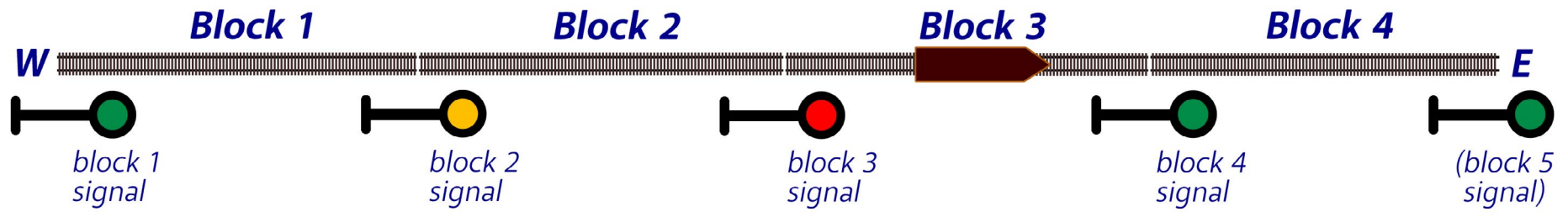

4. The eastbound train enters block 3, causing the block 3 signal to go red, block 2 to go yellow, and block 1 to go back to green.

NOTE: Block signal 5 is a placeholder shown without any block details.

**When talking to hobby vendors, please remember to mention MRH.**

**VIEW READER COMMENTS**  
*click here*



So you can see as the train proceeds eastbound through the blocks, this same sequence of signal aspects follow it, going red and then going yellow, and finally back to green [5].

*NOTE: Block signal 5 is a placeholder shown without any block details.*

## Four ABS blocks, eastbound train: block 4

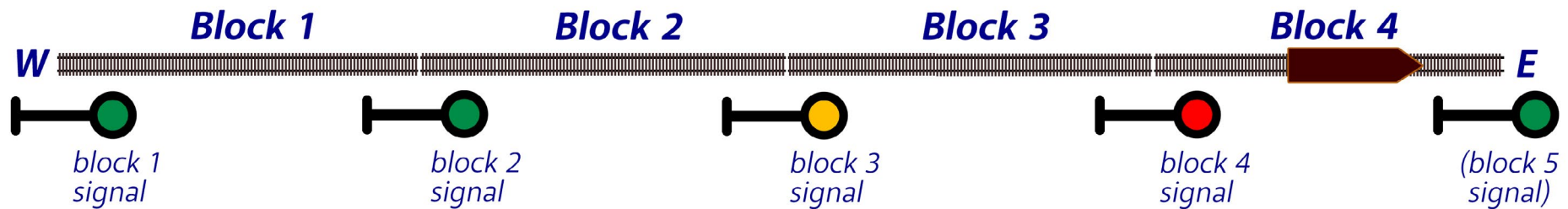

5. As the eastbound train enters block 4, the block 4 signal “drops” to red, block 3 goes to yellow, and block 2 returns to green.

Once you understand this basic foundation for ABS signaling, the rest of the discussion starts to make more sense.

### Making model railroad signaling work

For this simple four-block signaling circuit to be implemented on a model railroad, you need these things:

1. Divide the track into blocks with insulating gaps.
2. A way to detect there is a car or locomotive in the block.
3. A way to determine if any turnouts in the block have been thrown so their alignment diverges off the main.

Since most model railroad track is already powered, detection of a locomotive is easy: we can just add a current sensing circuit to determine if current is flowing across the rails.

However this doesn't work for railcars since the wheelsets are insulated. But if we add a special wheelset to the car with a resistor across the wheels (like 10K ohms), this allows a small current to flow. We can make the current-sensing circuit sensitive enough to detect cars with these resistor wheelsets.

Other methods for detecting a train can include optical sensors, but they work best for detecting entire trains, not individual cars in a block. For example, if you happened to leave a single car on the main somewhere, optical sensors might not detect it.



You also need a detection circuit or extra contacts to indicate the position of mainline turnouts.

Once you have your detection circuits set up, then you need something to take what the sensors are picking up and to translate that

## Model railroad ABS system components

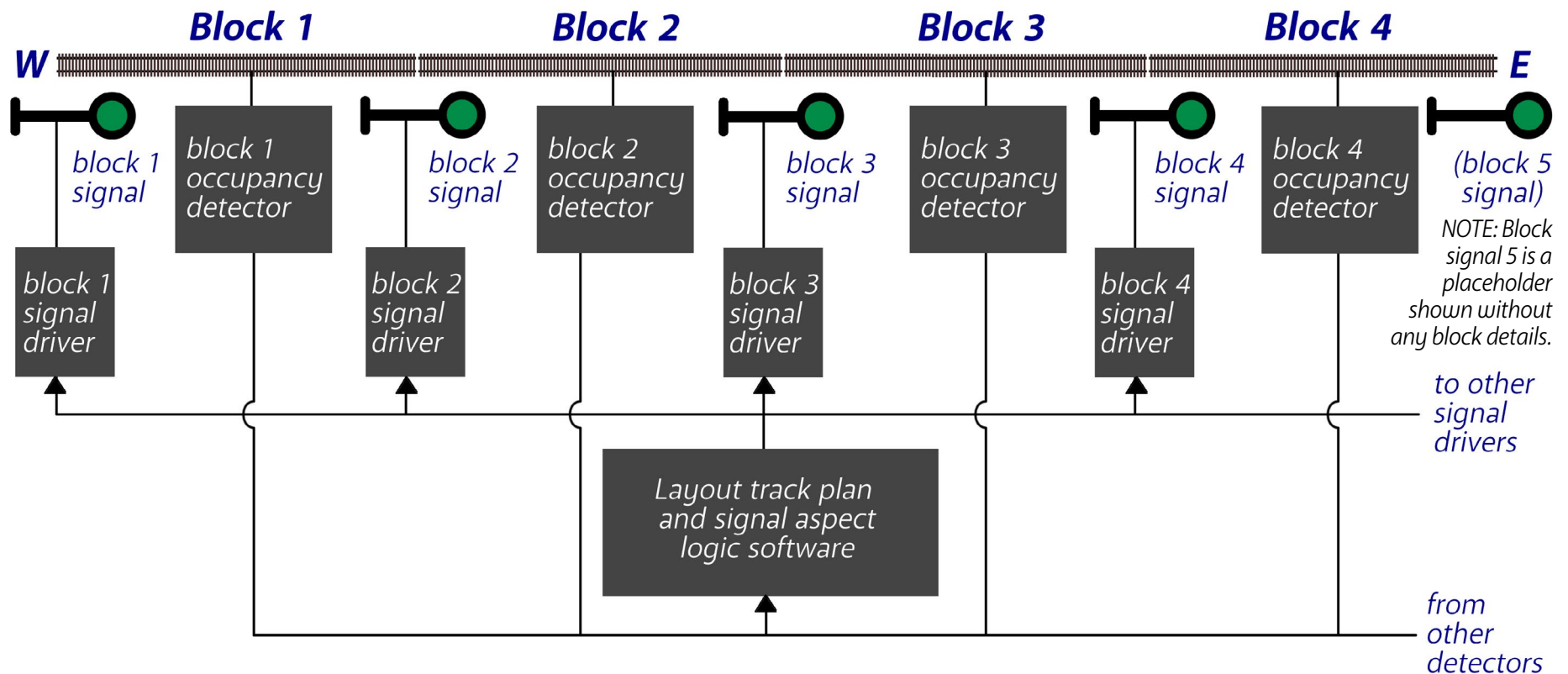

6. To make this simple four-block ABS system work for east-bound trains, these components are needed. If we also want signals for westbound trains, we will need another complete set of signals facing the opposite direction along the other

side of the tracks, along with signal drivers for them. As you can see, the total number of parts for this simple four-block ABS signaling system is significant.



into “make these signals show red, make these signals show yellow, or make these signals show green,” based on what’s being detected.

Most of the time, this “logic” to determine which signals show what on the model uses a computer program. To program the software, you need to give the computer an understanding of your track plan and where the signals are located.

For this logic, you can either have a central computer, or you can program local devices such as an Arduino with the needed decision logic.

Finally, you need a signal driver circuit to operate the signal itself. The signal driver takes the “display red, yellow, or green” command from the software and activates the proper leads to the red, yellow, or green LEDs in the signal.

If you have a semaphore signal, the signal driver will also need to drive the servos to move the arms to red, yellow, or green positioning.

In summary, you need these basic pieces for a model railroad signaling system to work [6]:

1. Detection sensors for each block
2. Software programmed with knowledge of your layout track plan, block boundaries, and signal locations
3. Signal driver at each signal to convert the aspect logic into the proper LED color or semaphore arm position.

You can then build on these basics to model just about any prototype signaling system you want to emulate. ■

**VIEW READER COMMENTS**  
*click here*

ADVERTISEMENT

## Great control in a tiny package



- Touch Toggle™ plug in controls
- Bright clear indication
- Easy setup
- Flexible system

Stall Motors, Twin-coils, Power, and Servos

Now for Tam Valley Depot and MRservo too!

**BERRETT HILL TRAINS**  
Made in the USA

What will they think of next? [www.berrethillshop.com](http://www.berrethillshop.com)

ADVERTISEMENT

## ProtoThrottle™

Realistic Control Stand Throttle

**DITCH THE “KNOB”**



**TAKE IT UP A “NOTCH”**



New run available in November - **DON'T MISS OUT!**

[WWW.PROTOTHROTTLER.COM](http://WWW.PROTOTHROTTLER.COM) LEARN MORE

ADVERTISEMENT

## TamValleyDepot.com

Celebrating 10 Years of Serving the Hobby 2008 - 2018



### Dual Frog Juicer

Automatic DCC Polarity Reverser

Power Two Frogs

- Crossovers
- Crossings
- Automatic Reverser for Turntables
- Wyes, Loops
- Circuit Breaker

MRH Supporter since 2009

Use with 2-10 Amp Systems





Complete Train Control

## Introducing the LNWI Wifi Interface

- **Wi-Fi interface to a Digitrax LocoNet for up to four compatible mobile Wi-Fi devices and Apps.**
- **Compatible with most Android and Apple devices running supported throttle apps**
- **Easy Setup and Configuration. A single LNWI works 'out of the box', with no additional configuration required.**



**LNWI Loconet Wifi Interface | \$79 MSRP**  
The LNWI allows you to connect compatible WiFi devices to LocoNet and run trains using compatible throttle apps

Find out how easy it is @ [www.digitrax.com/throttleapps/](http://www.digitrax.com/throttleapps/)







# NEW, LIMITED-RUN MICRO-TRAINS CARS

## Grand Trunk Western (GTW) 4-Pack



CLICK HERE FOR GTW 50' BOX CAR



AVAILABLE APRIL, 2019

50' Rib-Side Box Car  
Single Door without Roofwalk

Different Color Doors

Unique, filthy graffiti designs

## Canadian Pacific (CP) 4-Pack



CLICK HERE FOR CP 33' HOPPER

AVAILABLE MAY, 2019

33' Twin-Bay Hopper with Offset Sides

Black, White script lettering

Faded, filthy weathering

## Pacific Western Rail Systems

LIMITED RUN OF MINIMUM 50 SETS-MADE EXCLUSIVELY FOR PWRS BY MICRO-TRAINS



# WHAT'S NEAT



column

Model Railroad Hobbyist | October 2018 | #104

**KEN PATTERSON** REPORTS ON DISPLAY LAYOUTS, TONY KOESTER, AND MORE AT THE NATIONAL TRAIN SHOW AND THE NMRA NATIONAL ...



**THIS MONTH WE TAKE A LONG, DETAILED LOOK** at the NMRA National Train Show held in Kansas City, MO. The show was big and well attended, with hundreds

of manufacturer, distributor, importer, and hobby dealer booths filling the convention center.

Here I will present the four modular layouts that are in the video along with a few folks that I interviewed for the show. This month's video is the longest What's Neat show to date at 52 minutes with a lot of bonus material. There are six additional interviews with key players in our hobby like Joe Fugate, the editor of *Model Railroad Hobbyist*; Doug Blaine of Bachmann Trains, Craig Martyn from Atlas; a railroad apparel manufacturer, and a Z scale importer and publisher. ✓

▶ PHOTOS AND VIDEO OF SUPERB MODELING



## WHAT'S NEAT | 2



1. (Above) Tony Koester gave us a great interview. We discussed the trigger in youth that creates a passion for the model railroading hobby. If you could figure out what that trigger is, you could sell it! To Tony, the most important thing is simply promoting the hobby to beginners and advanced modelers alike.

2. (Top right) Phil Walthers and Stacey Walthers Naffah provided us with a very passionate and funny interview as 30 people stood in the aisle just outside the Walthers booth, filming us on their cell phones. That was an interesting sight.

**VIEW READER  
COMMENTS**

*click here*

## WHAT'S NEAT | 3





## WHAT'S NEAT | 4



3-5. Dusty McCoy, representing the Free-mo layout, talked to us while standing in front of the 30-foot long Tunkhanock Viaduct segment. The original was built in 1915 on the Delaware, Lackawanna & Western Railroad's Nicholson Cutoff,

## WHAT'S NEAT | 5



crossing Martin's Creek with 10 spans. The bridge is a scale 2375 feet long and 240 scale feet high. The structural core is made from 1/4-inch MDF and pink foam. It took three years to build the model, just as the prototype took the same period to complete.

The display took two years of planning and took 22 hours to set up at the show. Missouri Valley Free-mo, Southern Kansas Free-mo, and the Southern California Free-mo group, along with modules from eight other states made up the layout. The 61 modules created 500 feet of HO scale mainline trackage. The layout was operated at the show with a dispatcher and clock. The realistic scenery flowed from module to module with the track at a standard 50 inches high, which was perfect for viewing the 50-car trains running along the main lines.



Also see the new "What's neat this week" weekly video podcast!





## WHAT'S NEAT | 6

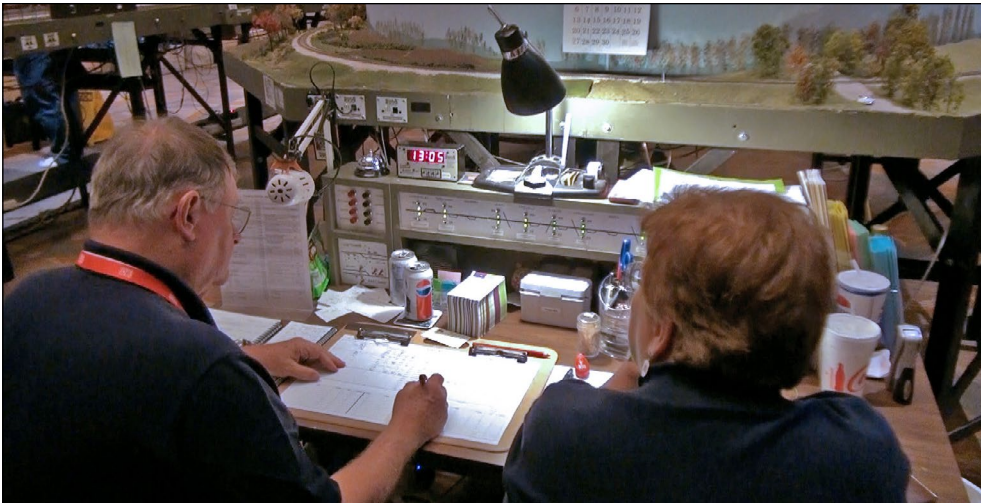

6-9. The Operations Road Show modular layout was set up in the Westin Hotel ballroom near the NMRA National Convention contest and clinic rooms. The layout is built to teach operations, with full dispatching. It took 12 people in groups of two to operate the layout for a standard three-hour session. Road show volunteers took the time to teach each visitor the process of operation with 400 feet of mainline that

## WHAT'S NEAT | 7



runs through eight towns. There are passing sidings, working telephones, and train order offices at each town. It was fascinating to watch as the trains ran through the railroad's 34 modules. A backdrop runs up the center, dividing each module into two sides about 12 inches deep. It is a great way to double the scenery and trackage in just one module six to eight feet long.





## WHAT'S NEAT | 8



10. Tom Flores from Train Traxx.com showed us the RFID technology tags that can attach to each freight car to keep track of them on the layout. As the car's data is processed by a reader, information like loads empty or full and destination will appear. It's a very interesting product that would add to an operating session. A basic system with three readers and 25 RFID tags costs around \$179. Visit [www.traintraxx.com](http://www.traintraxx.com) for more information.

**VIEW READER  
COMMENTS**

*click here*



Also see the new "What's neat this week" weekly video podcast!

**WATCH  
NOW >>**



*Have you seen this?*



*click to play video*

**kenpatterson.com**

*click here to ...*

**Visit Ken's website**

**Ken Patterson  
reveals his modeling  
secrets on video!**

**CHECK IT  
OUT!**





Also see the new "What's neat this week" weekly video podcast!

**WATCH  
NOW >>**

11-12. (Left top and bottom) The Lego layout was colorful and amazing. I know what you're thinking. Lego is too toy-like. Well, boy, did I get a lesson on how challenging it is to model in Lego. All the items on the layout, buildings and trains, are scratchbuilt. There is no packaged Lego Pennsy T1 kit, but there was a scratchbuilt one on the layout. You must figure the locomotive's dimensions from drawings of the prototype, then figure which bricks and parts will get you to that end. That's not easy, and did I mention, they never glue their parts together. Drop it and it's a mess, as Glen Holland demonstrated when he accidentally dropped a Mo-Pac caboose on the floor during the video interview. It made my point that I would lean very much towards the direction of using glue.

The layout's scale is a little larger than O scale (1/48th scale), coming in at around 1/46th scale. The layout on display was set up by two groups, the Penn Lego Users' Group (PLUG), and the Texas Brick Railroad supplying the switchyard and roundhouse.

**Please  
mention  
MRH when  
speaking  
with  
advertisers.**

**VIEW READER  
COMMENTS**

*click here*







**N**  
SCALE

# "THE DRAPER TAPER!"



CLICK  
HERE



**RAPIDO**  
TRAINS INC.

## GE DASH 8-40CM

EIGHT PERFECTLY REPRODUCED PAINT SCHEMES



QUEBEC NORTH SHIELD & LABRADOR IS A CONVENTIONAL AND/OR OVERHEAD. IF IT DOESN'T REACH OUR MINIMUM ORDER IT WON'T BE MADE. TWO UNDECORATED VERSIONS.

**ORDER DEADLINE NOVEMBER 19TH, 2018. DELIVERY MID-2019**

MRHMAG.COM



REGISTER  
(free)

• [INDEX](#)

• [TABLE OF CONTENTS](#)

WHAT'S NEAT | 11



13. The Colorado Model Railroad Museum from Greeley, CO set up a booth at the show with Michelle Kempema, CMM executive director promoting their wonderful 5500 square foot operating HO scale layout along with a large collection of railroad artifacts, a functioning dispatchers panel, and a restored Colorado & Southern caboose. For hours and directions go to [cmm.org/tours.html](http://cmm.org/tours.html).

**VIEW READER  
COMMENTS**

*click here*





14-15. The T Track Modular layout was comprised of 330 N scale modules brought to the show by 60 individuals. This group set a new world record for modules set up at a show in one layout. Each module was the size of a painting. The concept comes from Japan, where modelers create their scenes on 12-inch squares of foam board. The modules use Kato N scale Unitrack on the ends to join the modules. The sections have leg levelers built in each corner with 1¼ inches of travel, to allow for level track on uneven convention tables. Each module is different in color and theme. They were flawless in operation and simple to build. Many of the members are new to the hobby as this club welcomes newcomers with this simple modular idea for N scale. ☑

2003 Celebrating 15 Years! 2018  
OF TRACK BUILDING INNOVATION

# FAST TRACKS

Build your own trackwork easily, quickly, and affordably.

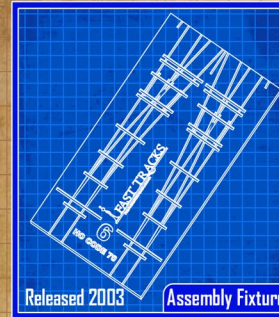

Released 2003 Assembly Fixture



Released 2004 Filing Tools

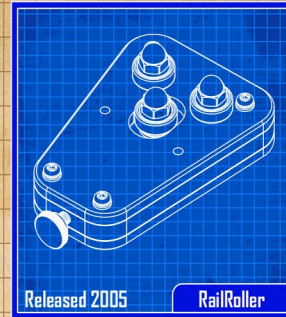

Released 2005 RailRoller



Released 2005 Tie Rack

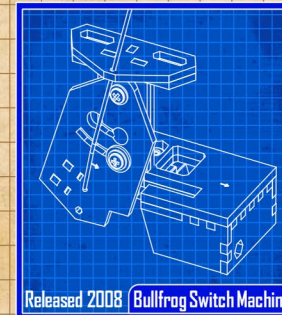

Released 2008 Bullfrog Switch Machine

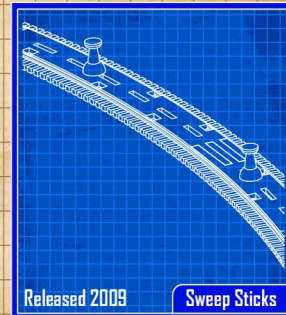

Released 2009 Sweep Sticks

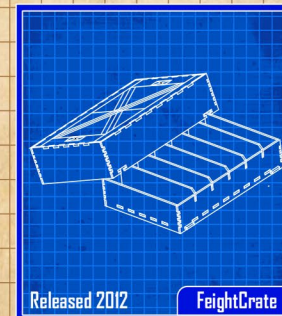
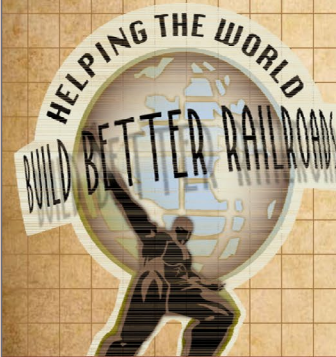

Released 2012 FreightCrate

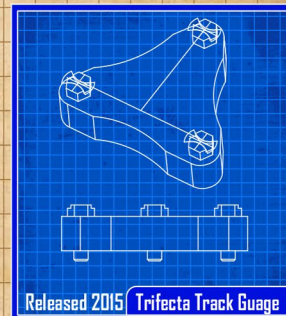

Released 2015 Trifecta Track Gauge

Easy ordering • Live online support • Earn Waypoints with every purchase

shop online 24/7 handlaidtrack.com

1-888-252-3895 service@fast-tracks.net



# MRH MARKETPLACE



MRH MARKETPLACE | 2

**PRE-SIZE**  
MODEL SPECIALTIES

P.O. Box 6 Paonia, CO 81428  
Ph. 970 527 4586  
Made in The USA

Cast resin items for All Scales.  
Tunnel portals, bridge piers, abutments,  
culverts, and retaining walls.  
Trackside details and sage brush tree  
armatures.

"FREE SHIPPING see website for details"



**LOGIC RAIL**™  
TECHNOLOGIES

"Sophisticated  
Model Railroad  
Electronics"

Please visit our website and online store!

21175 Tomball Pkwy Suite 287 Houston, TX 77070  
Phone: (281)251-5813  
<http://www.logicrailtech.com>  
info@logicrailtech.com

**Yarmouth Model Works**  
HO scale resin kits and detail parts

U.S.A. MAILING ADDRESS  
2014 Holland Ave Unit 617  
Port Huron, MI 48060

TEL: 519-633-7574  
pierre.oliver@elgincareshops.com  
[www.yarmouthmodelworks.com](http://www.yarmouthmodelworks.com)

CANADIAN MAILING ADDRESS  
263 Sunset Dr.  
St. Thomas, ON N5R 3C4

*Imagine That!*  
Laser Art Products

**ITLA Scale Models**  
Cooper's Alley  
HO Scale - Precision Laser Cut Wood Kit

CLICK HERE FOR MORE INFORMATION  
[www.itlascalemodels.com](http://www.itlascalemodels.com)

**MAIN STREET AMERICA  
HISTORIC ARCHITECTURE**

**MAIN STREET  
HERITAGE** CLICK HERE for all our HO & O kits

[www.mainstreet-heritage.com](http://www.mainstreet-heritage.com)

**Fall Orange** csp  
**Trees**

**OLD WEST  
SCENERY**  
★ EST. 2016 ★

**N SCALE OLD WEST  
BUILDINGS & SCENERY**

REALISTICALLY DESIGNED & DETAILED  
FULLY ASSEMBLED 3D LASER PRINTED PRODUCTS

★ NO SMALL PARTS ★  
★ NO GLUE ★ NO MESS – NO FUSS

LOOK at what's new at Black Cat this month

Click here for our website

**CP wood express reefers from the 20's. in Dulux gold or gold leaf lettering**

**Black Cat Publishing**  
(204)489-5005  
ajfergus@mymts.net  
blackcatdecals.com

**CROW RIVER PRODUCTS**

O Scale Kit 335-D  
Motor Conversion for Machine Tools  
Shown adapted to our 335-A Engine Lathe

Our Machine Tool kits are of the overhead belt type. This kit, allows for attaching an electric motor directly to the machine. The Kit includes a new style electric motor, A base and various pulleys and hardware.  
Made in USA \$12.00

**HO & O Scale Machinery, Derricks, Engines, Hardware & Waterfront Models**  
Pawtucket, RI 02861 Tel 401-723-0065  
[www.crowriverproducts.com](http://www.crowriverproducts.com)

**WESTERFIELD** GOLDEN AGE LINE  
MODELS, LLC

**USRA DS Express Box  
NWP Redwood Empire**

[westerfieldmodels.com](http://westerfieldmodels.com)

CLICK TO REGISTER NOW  
- IT'S FREE!



## MRH MARKETPLACE | 3

## Altoona Model Works

Railroad Track Side Structures in O & HO scale  
Museum Quality Workmanship

ALTOONAMODELWORKS.US  
814-793-7016

Click here for  
the more ...



## Model Railroad Control Systems

Geoff Bunza Project Boards  
DCC Occupancy Detectors  
CMRInet Compatible Nodes  
Layout Telephone Systems  
RFID Switchlist Generator  
Switch Machines and Drivers



## MasterpieceModules.com

T-trak Module Kits & more  
CNC machined precision finger joints  
parts are self-locating & self-clamping  
All hardware is included

MONASHEE  
LASER  
ENGINEERING

COME VISIT  
US HERE



MANUFACTURERS OF FINE RAILROAD  
STRUCTURES AND ROLLING STOCK MODEL KITS

IF WE CAN DRAW IT ...

## MOUNTAIN SUBDIVISION HOBBIES

[www.modelrrsupply.com](http://www.modelrrsupply.com)

FREE USA SHIPPING OVER \$39.00

NCE - SOUNDTRAXX - DIGITRAX - ESU LOKSOUND  
SPROG - DCC SPECIALTIES - INTERMOUNTAIN - CMX  
BAR MILLS - BOWSER - ATLAS - CIRCUITRON - PECO  
RIX - PIKESTUFF - CENTRAL VALLEY AND MORE!!!

## PRECISION DESIGN CO.

LASERCUT KITS - CUSTOM DECALS

**PDC.CA**

Authorized *RailPro* Dealer

FREE SHIPPING in the US and CANADA

## Great Decals!™

FEC, Interstate, Virginian  
Railway, & L&N Titles  
After Hours Graphics Line  
Coupler Gages and More  
In O, S, HO, and N Scales



## HO DIESEL SUPPLY

CUSTOM SOUND LOCO'S-REPAIRS-UPGRADES  
Weathered New and Rebuilt Locomotives  
Powered Chassis-Trucks-Motors-Handrails-Electronics  
Parts Inventory Always Changing  
[www.hodieselsupply.com](http://www.hodieselsupply.com)  
email:gerry@hodieselsupply.com

# Ultimate switching tutorial

## Up close and personal ...

with Mike Confalone

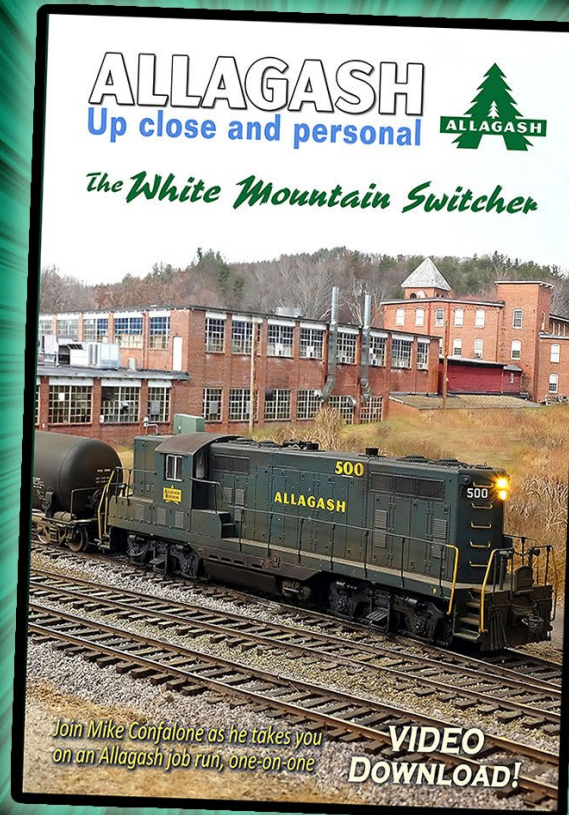

Pre-order  
and **SAVE!**

DVD media  
~~\$29.99~~

**\$24.99**

FREE shipping US  
50% off shipping foreign

Video download  
~~\$14.99~~

**\$9.99**

HD  
format

Running time: 2 hours (Releases end of September)

Pre-order White Mtn Switcher

from the  
**Model Railroad  
Hobbyist Store**





# Adding DCC and LEDs to **Blue Box** locos

STEP  
by  
STEP  
1-2-3



*LES GREEN shows how to breathe new life  
into your old Athearns ...*

1. Les explains a tidy and foolproof installation system.







RATE THIS ARTICLE

## WE HAVE ALL SEEN ATHEARN BLUE BOX

locomotives and many of us have some. You regularly find them at swap meets and train shows, but in the age of DCC they are often overlooked in favor of more modern quick-plug DCC ready units.

As a budget-minded modeler, I like upgrading these older Athearns. For the price of one new Kato unit, I can buy five or six of these older units and put in decoders.

I wired my first DCC locomotives with the intention of one day converting them to DCC sound. I wanted swapping out a decoder to be easy so I included an NMRA 9-pin decoder edge plug in each Blue Box upgrade.

The best deal I've found on a 9-pin decoder is NCE's D13SRJ 10 pack. I ordered a set of them and developed an install process that keeps the wires out of the drive train. I have converted over 50 locomotives at this point, and my install procedure has evolved from my first attempts to the method I show here.

## Doing the installation

In this tutorial I will show you how to convert a classic Athearn Blue Box locomotive to DCC using simple tools and techniques.

Tools and parts used in this tutorial:

- HO scale Athearn Blue Box loco, Athearn RTR without a quick plug

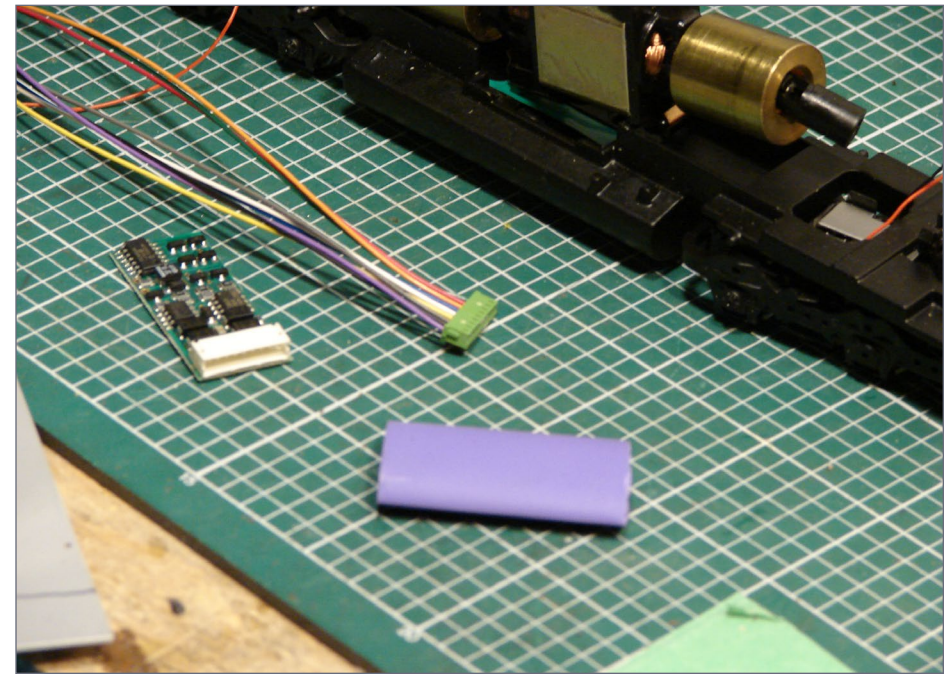

## 2. My preferred decoder: NCE D13J decoder I use in this article.

- DCC decoder: Started with the NCE D13SRJ and upgraded to the D13J. See [2].
- Soldering iron
- Shrink tubing 1/2" & 1/8"
- Electrical tape (we recommend Kapton tape – ed.)
- Double sided foam tape 1/2" wide
- Drill bits: 3/32" & 1/32" (2mm & 1mm)
- Pin vise for drill bits
- Flush cutters
- NMRA HO scale standards gauge
- 30 AWG decoder wire (Walthers Part #745-1468 or similar)
- Felt marker





## DCC AND LEDs FOR BLUE BOX LOCO | 5

- Wooden pencil with a soft pink eraser
- Cut-off disk on a rotary tool
- Micro screwdriver set
- Holding devices (extra hands set, hobby clamps, etc.)
- DCC system (I use an MRC Prodigy Express2)
- DC controller
- Multimeter
- Alligator clip test leads
- Lube oil
- 0.020" polystyrene sheet (Evergreen or similar)
- Sand paper, sanding sticks, files, etc.

Because I always have more than one project on the go at a time I find it extremely important to clear my work area of anything that might get confused with the unit I am working on.



J. Fugate

## KAPTON TAPE

What's the big deal with Kapton tape for DCC installs? The adhesive works very well on flat surfaces, the tape is extremely thin, and it has excellent heat resistance. This MRH forum thread has all the details ...

**WEB:** [mrhmag.com/node/20728](http://mrhmag.com/node/20728).

## HOBBY CLAMP

Les uses a tool in this project he calls a "hobby clamp". The official name for this tool is hemostat, and you can find some great hemostat buys on Amazon. The link below is for a set of eight at a cost of \$12 with free shipping!

**WEB:** [a.co/d/6yK3VGz](http://a.co/d/6yK3VGz).



## DCC AND LEDs FOR BLUE BOX LOCO | 6

I would also recommend using the box top from your unit as a parts tray to keep any small parts safe from loss. Keep in mind there are very few replacement parts available!

Before we begin, you must choose which end of our locomotive will be the front. For this article, the front of the locomotive is always to the right.

LAST CALL!

FINAL KIT!



**FINE SCALE MINIATURES**  
FSM is closing its doors after 50 years of business!

Model by Frank Bernard



ONCE GONE, THAT'S IT!

Brought to you by the MRH Store: [store.mrhmag.com](http://store.mrhmag.com)I.M. Dunn Co.  
\$280 + S&H*Destined to become an instant collector's item***BUY NOW >>**



## STEP 1: TAKE OFF THE SHELL

There are two different types of shell retention devices. These pictures [3a, 3b] show the side retainers while the other picture [4] shows the internal retainers.

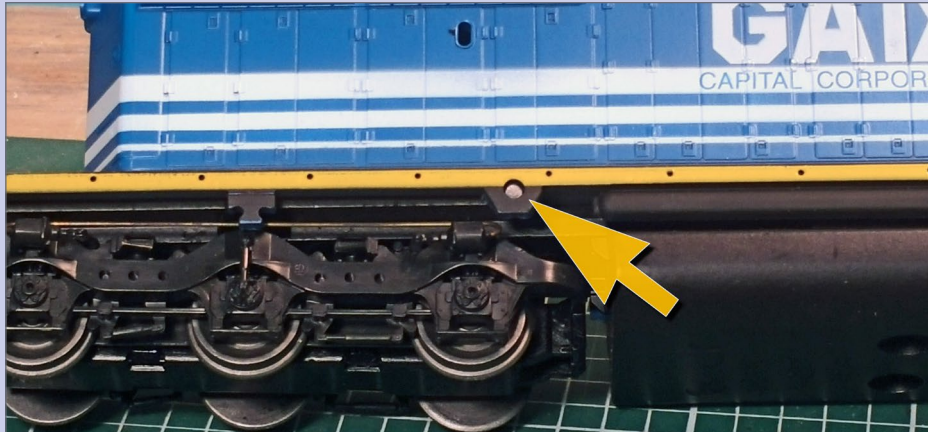

**3a, 3b. Finding shell retainer pins:** Shell side retainers are used on many Blue Box locos.

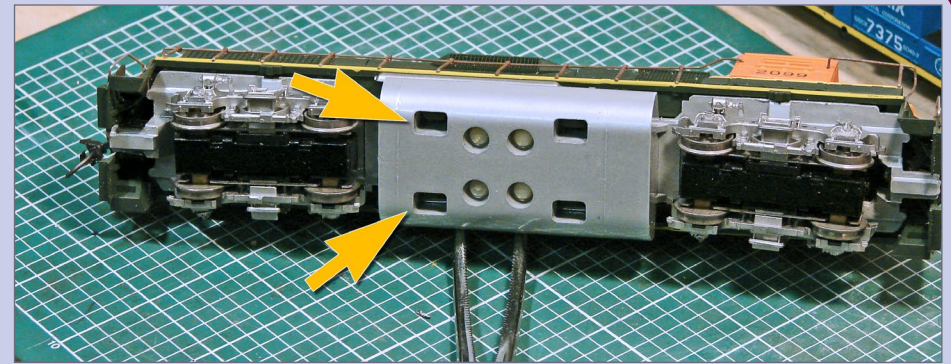

**4. Some locos use bottom pins:** These bottom internal shell retainers are used on some Blue Box locos.

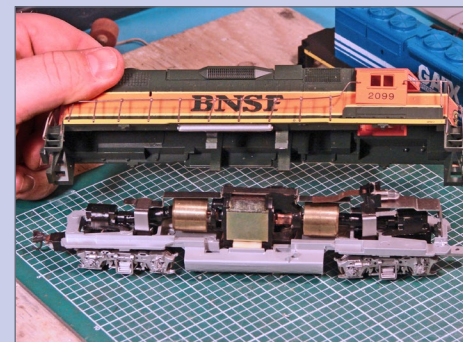

**5a, b, c. Removing shell with bottom pins:** To remove a shell which has the bottom internal retainers, grip the fuel tank, and gently squeeze and rock the body until it comes off.



STEP 1: TAKE OFF THE SHELL *CONTINUED ...*

- **To remove the side-mounted retainers**, gently pull the body away from the frame while pressing up. If the loco has never been apart or has been repainted, this could take some effort. Try not to use tools unless necessary as too much leverage could break the shell. Repeat for the other side, then lift the body away.
- **For the bottom internal type retainers**, grip the body in one hand with your fingers as low on the sides as you can get [5a, 5b, 5c]. Grab the fuel tank with the other hand. Then gently squeeze the body while rocking it side to side. The body should lift off. *(It can sometimes be a good idea to take the handrails off, too. – ed.)*
- Set the body aside for now.

**Please include  
a phone  
number when  
emailing MRH  
(just in case  
your spam filters  
eat our email  
response)**

**VIEW READER  
COMMENTS**

*click here*

## STEP 2: DETERMINE MOTOR CURRENT DRAW

I show two different chassis examples for reference.

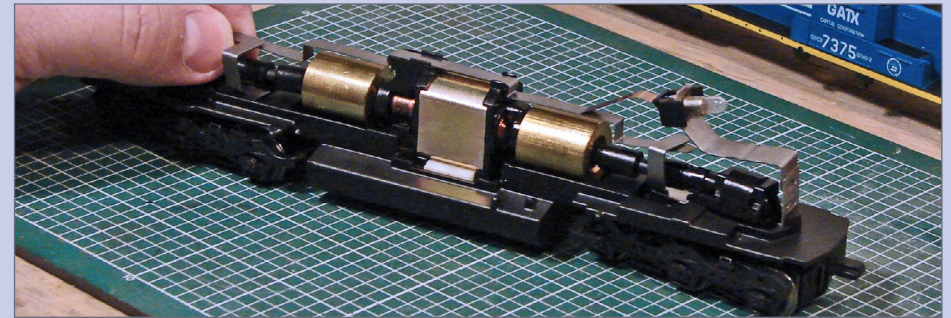

**6a. Stock Athearn chassis:** Standard Athearn Blue Box with metal strap wiring.

The first example [6a] uses the stock Athearn Blue Box metal strap for conductivity between the trucks and the top of the motor.

The second chassis example [6b] has been wired directly by the previous owner. This is common in the used market as it makes electrical pickup more reliable on tight curves. People refer to it as “hard-wired.”

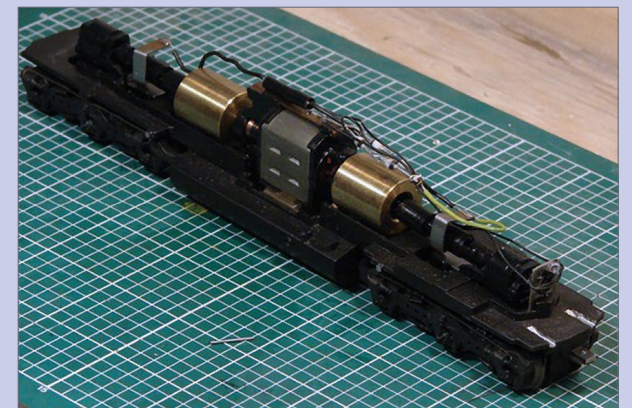

**6b. Hard-wired by owner:** Example of aftermarket wiring added by a previous owner.

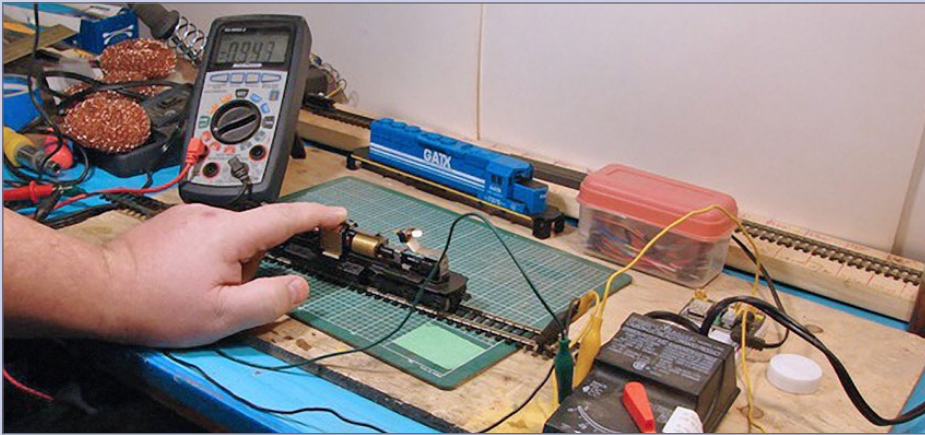
STEP 2: DETERMINE MOTOR CURRENT DRAW *CONTINUED ...*

**7a. Current-draw test set-up:** Here is my set-up for testing current draw, with a power source and a multimeter.



**7b. Forward reading:** Stall current reading in forward.



**7c. Reverse reading:** Stall current reading in reverse.

To determine the loco's current draw, mount a piece of track on a 2-foot long board. Get a DC power pack and a multimeter, along with some test leads [7a].

Use this procedure:

1. Hook up a DC power pack to one rail of the track with a test lead.
2. Clip the red lead of the multimeter to the other terminal on the power pack.
3. Clip the black multimeter lead to the other rail on the track.
4. Turn on the multimeter. Make sure it is set to DC Amps and at the 10A setting.
5. Place the loco (minus the shell) on the track.
6. While holding the loco from moving (in other words, forcing it to slip), turn the power pack up to full power.
7. With the loco slipping and held in place, read the amp draw [7b].
8. Reverse direction and read meter again [7c].
9. Turn off power pack.

Refer to the decoder manual to find the maximum allowed amp load.

1. The NCE D13J decoder motor rating is 1.3A continuous, 2A peak stall
2. My stall test reading was 0.880A, easily under the decoder's 2A peak stall current. Always use the higher amp reading of the two directions.



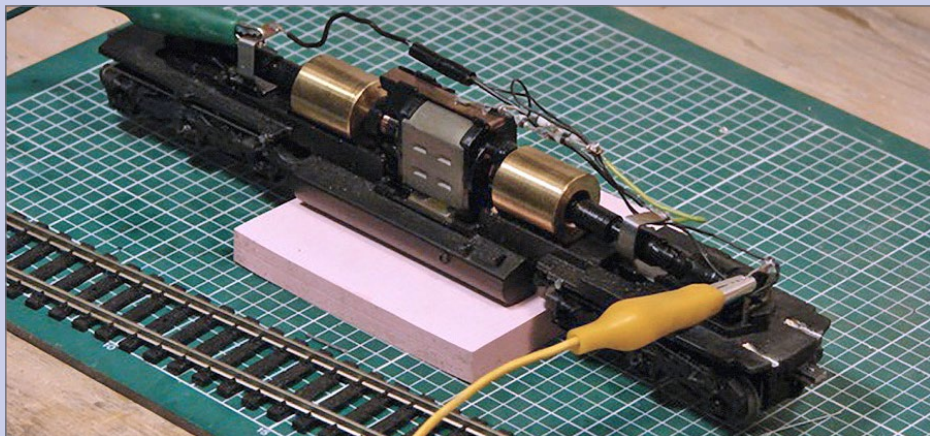

STEP 2: DETERMINE MOTOR CURRENT DRAW *CONTINUED ...*

**8a. Motor contact cleaning set-up:** To clean the motor contacts, put the loco fuel tank up on something so the wheels can spin freely, and clip on test leads from a DC power pack.

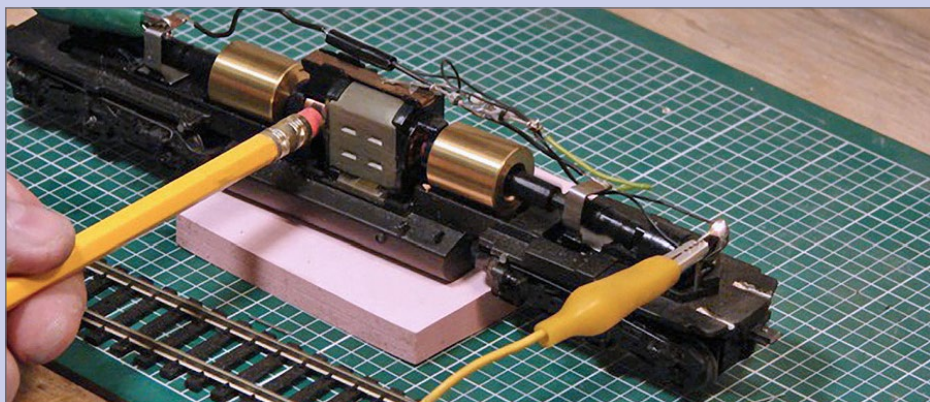

**8b. Clean motor contacts with pencil eraser:** Turn up the DC power to a good speed, then take a pencil with a soft pink eraser and hold it against the motor contacts (commutator) as it spins to clean off built-up carbon.

If the contacts on the motor are dirty, this is a great time to clean them before you put your DC power pack away.

1. Place the fuel tank on something to keep the wheels off the ground [8a].
2. Connect one test lead to the light socket mount on the front of the frame. Connect the second lead to one of the towers on the trucks.
3. Turn the power pack up to a good speed.
4. Use a pink eraser on the end of a pencil to remove excess carbon on the contacts by lightly pressing the eraser into the side of the motor and moving it back and forth until the contacts are clean [8b].

**Use our custom  
Google search on the  
MRH website to find  
topics of interest**

[CLICK TO FIND OUT MORE](#)

## STEP 3: DISASSEMBLE THE CHASSIS

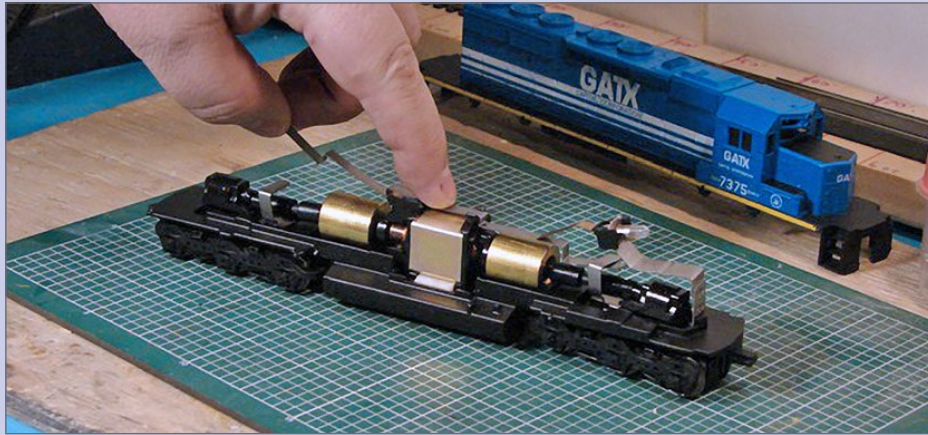

**9a. Removing the metal strap:** Slide the conductivity strap to one side to free it, then unclip it from the top of the motor.

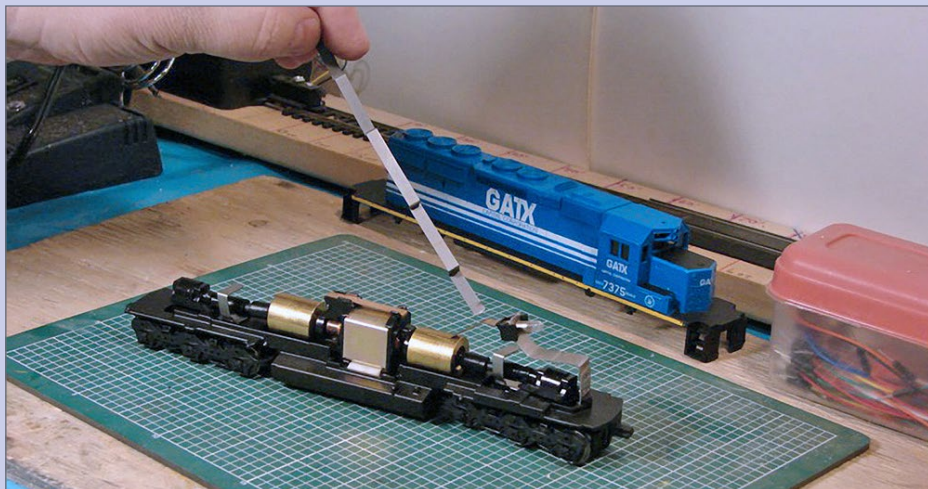

**9b. Set metal strap aside:** Once the conductivity strap has been removed, set it aside.

Use this process to disassemble the chassis.

1. Remove the motor connector strap by sliding it sideways and then unclipping it from the top of the motor [9a, 9b]. Remove it and set it aside. If a previous owner added soldered wires, use a soldering iron to melt the solder and remove the wires.
2. Remove an old-style crimped-on light by using a pair of cutters to cut the light loose from the mount. Remove a new-style light by rocking it side to side while pulling up [10a, 10b]. Set the light aside.
3. Remove both worm gear cover clips using a small flat blade screwdriver. Pry one side in the middle until it comes loose. Set both cover clips aside for later reuse [11a].
4. Gently remove the worm gears and drive shafts from both ends [11b, 11c].
5. Be *very* careful with the loose parts! If you lose one of the square bearings or thrust washers, you won't be able to put the unit back together! Put all the parts in the loco box lid and put the lid in a safe place.

**VIEW READER  
COMMENTS**

*click here*



### STEP 3: DISASSEMBLE THE CHASSIS *CONTINUED ...*

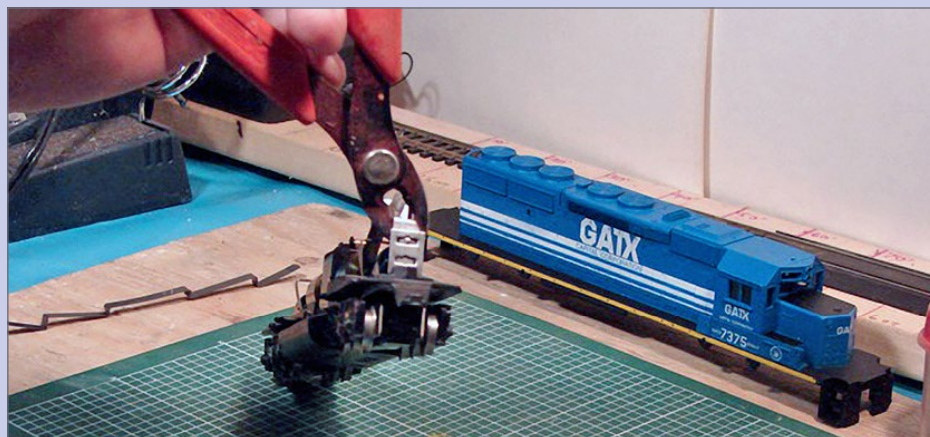

**10a. Remove light bracket:** Lift and rock the light bracket to pry it loose from its mount.



**10b. Set light aside:** Once the light is removed, set it aside.

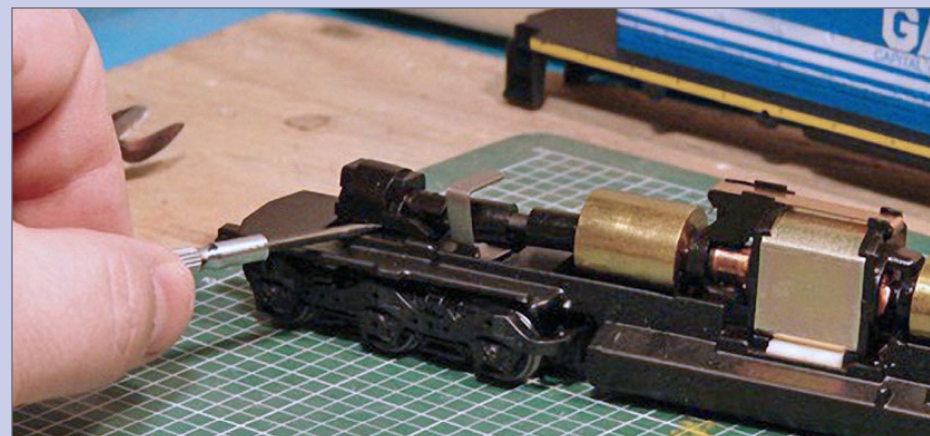

**11a. Remove worm gear clip:** Pry up on the middle of the worm gear cover clip to remove it.

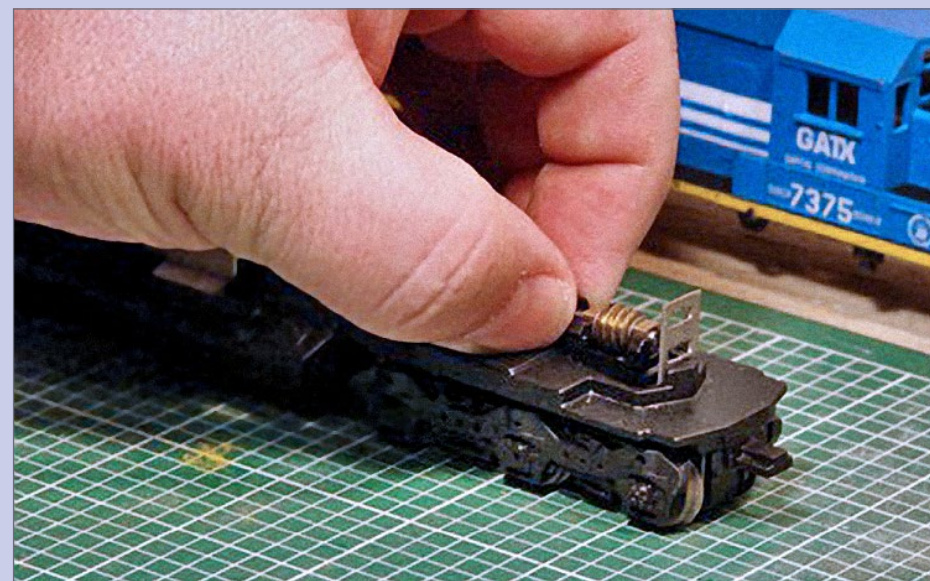

**11b. Remove worm gear:** Once the worm gear cover clips are removed, lift out the worm gear and its block mounts.

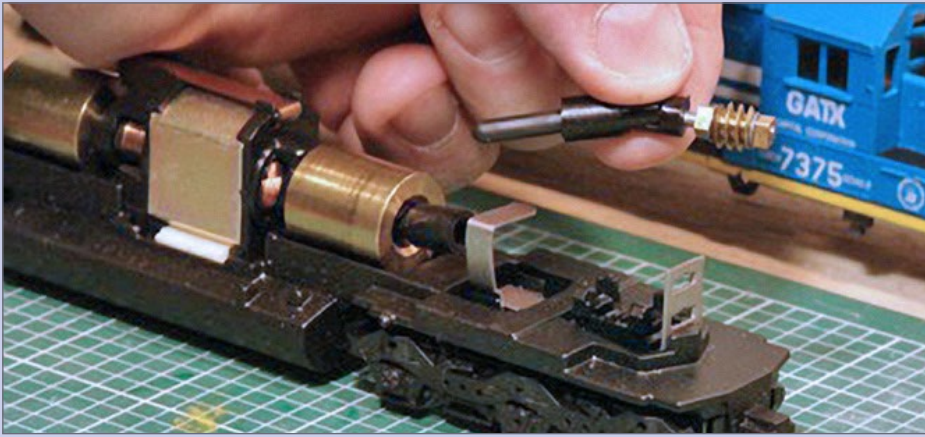

STEP 3: DISASSEMBLE THE CHASSIS *CONTINUED ...*

**11c. Set aside worm gear and shaft:** Pull the shaft out of the coupler on the flywheel and carefully set the worm gear assembly aside. Be careful not to lose any of these parts!

**Use this process to remove the trucks and motor.**

**NOTE:** Do not mix up the trucks! Remember which truck came from which end – put a dab of white paint on the rear one. That is the left truck – the front is facing the right, remember. This becomes important in later steps.

**VIEW READER  
COMMENTS**

*click here*



**12a. Remove trucks:** To remove a truck, lift the frame.



**12b. Set trucks aside:** With the frame completely clear, set aside the truck.

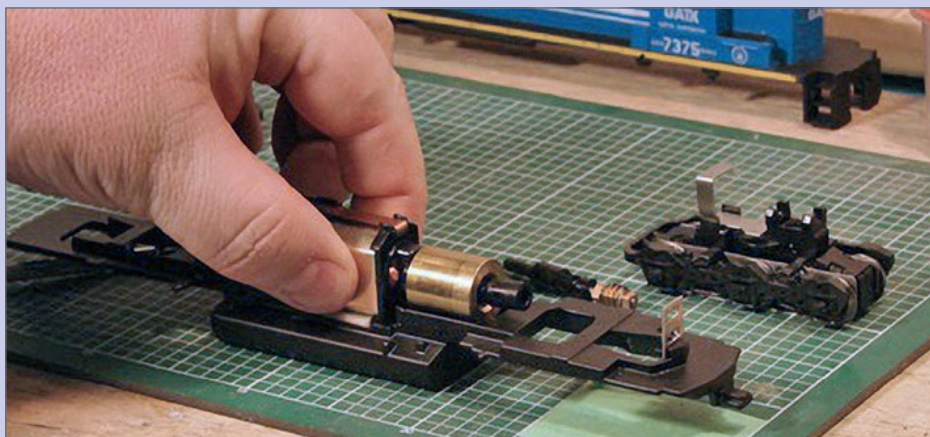

STEP 3: DISASSEMBLE THE CHASSIS *CONTINUED ...*

**13a. Remove motor:** To remove the motor, gently rock it from side to side, working the motor mount free.

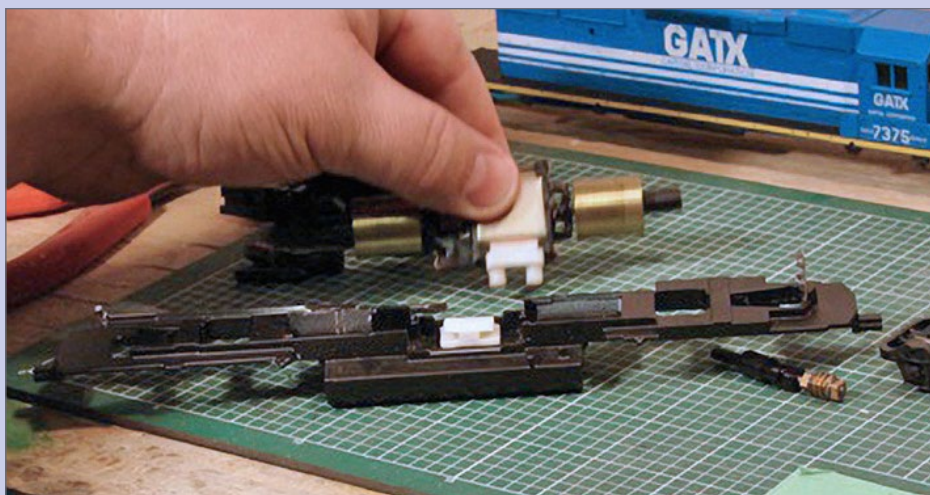

**13b. Lift motor free:** Once the motor is free, lift it from its mount. The other mount will typically stay in the frame.

1. Lift the frame at one end to clear the trucks [12a, 12b]. Repeat for the other end.
2. Remove the motor from the chassis by rocking it side to side until one of the motor mounts works free [13a, 13b].

Both mounts may be brittle or just plain stuck. If the mounts don't come free with the rocking method, or they are the old transparent ones, you will need to use a different method.

- Turn the chassis upside down. Using a blunt instrument (I use a 3" #1 Robertson square driver bit) to push the mounting tabs out and free the motor.
3. Set the motor aside. Turn the frame over and use a blunt tool to push out the remaining motor mount [14a-14c]. You may have to go back and forth between the holes to get a mount to come out in one piece.

136,000 have seen this MRH video - *have you?*

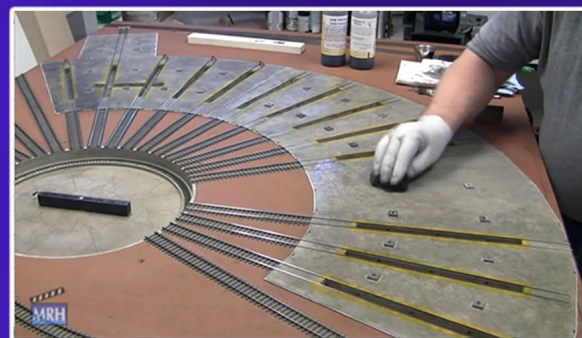

Watch the  
video now



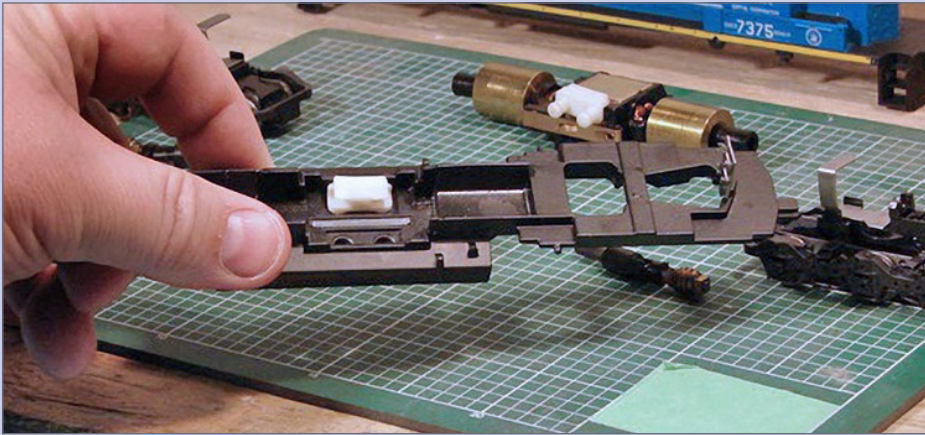

STEP 3: DISASSEMBLE THE CHASSIS *CONTINUED ...*

**14a. The other mount:** If the other motor mount remains, which is typical, you will need to work it out from below.



**14b. Access the mount from below:** Holes in the bottom of the fuel tank give access to the other motor mount.

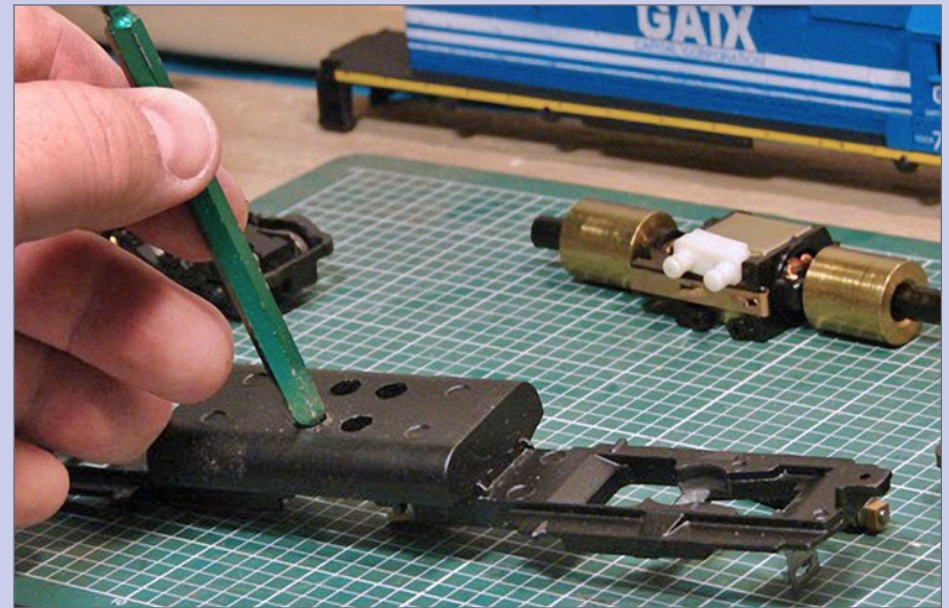

**14c. Poke other mount free:** Use a pencil or pen to press on the motor mount through the holes until the mount pops free.

If you can't get the mounts out in one piece, they are available from Athearn.

(Part ATH84026, [athearn.com/Products/Default.aspx?ProdID=ATH84026](http://athearn.com/Products/Default.aspx?ProdID=ATH84026)).

Also check with your local hobby shop. They may have some, or a parts unit you can pick up.





STEP 3: DISASSEMBLE THE CHASSIS *CONTINUED ...*

Use this process to remove the light bracket.

NOTE: If you go with the wiring method in the sidebar “Simpler truck wiring alternative,” then skip this step.

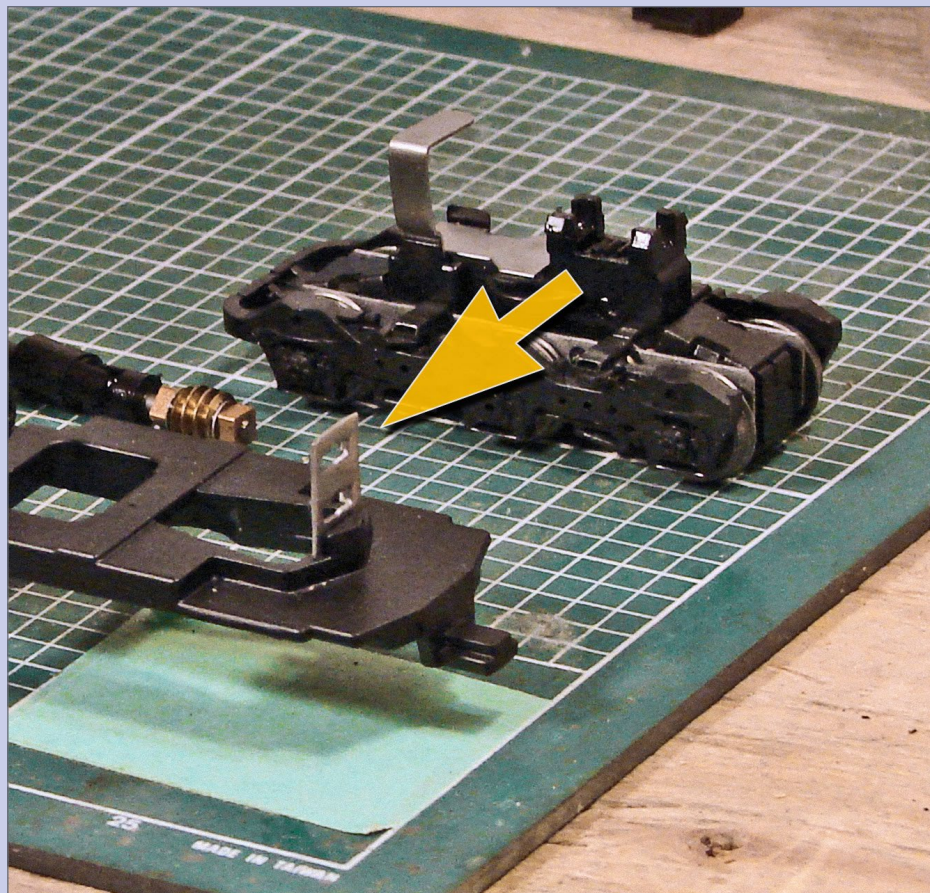

**15a. Light bracket:** The light bracket on the end of the frame needs to be removed.



**15b. Bend until snaps free:** Bend it back and forth with pliers until it breaks loose.

1. Using pliers, twist the bracket back and forth until it breaks loose [15a, 15b].
2. Discard the bracket.

★★★★★  
RATE THIS ARTICLE



## STEP 3: DISASSEMBLE THE CHASSIS *CONTINUED ...*

While the loco is apart, check the wheel gauge.

1. Using a NMRA HO scale standards gauge, check all axles for proper gauge [16].
2. If you find one or more wheels out of gauge, you will have to adjust them or replace them. Be sure to get the correct wheels for your type of engine. ([ATH40029, athearn.com/Products/Default.aspx?ProdID=ATHG63835](http://ATH40029.athearn.com/Products/Default.aspx?ProdID=ATHG63835))

Adjust the wheel spacing by gently twisting the wheelsets in the center gear. You will need to pop off the bottom retaining clip to lift the wheelset assembly out of the power truck.

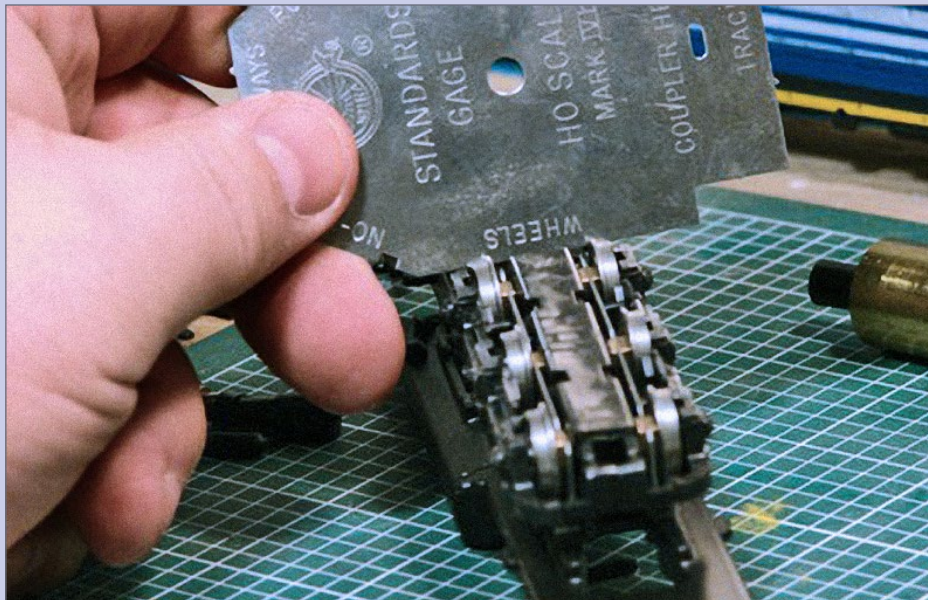

**16. Check wheel gauge:** While the loco is on the workbench, check the wheel gauge and correct any out-of-gauge issues.

Now that the disassembly is complete, let's move on to DCC installation and reassembly.

**VIEW READER  
COMMENTS**

*click here*

ADVERTISEMENT

## Announcing MRH Running Extra!

(Renamed from the MRH Premium Edition)

~350 pages, \$1.99 ea.  
1 year sub: \$19.99

All the free MRH content with ads plus another ~150 pages of ad-free in-depth articles and columns.

You can buy and download single issues or get a 12-issue subscription.

**Subscribe to  
Running Extra**

*click here*

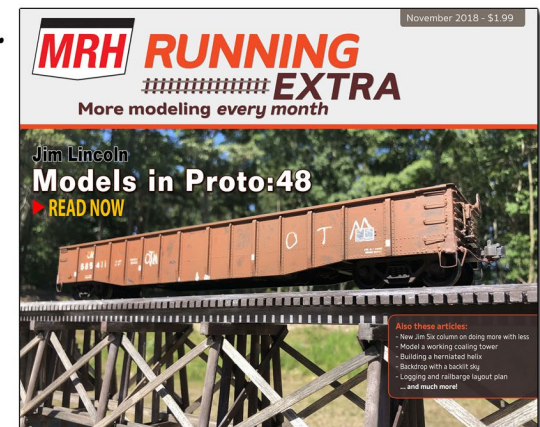



## STEP 4: ISOLATE THE MOTOR

You must electrically isolate the motor from the frame to prevent destroying the decoder and releasing the magic smoke.



**17. Tape the frame:** Apply insulating tape to the frame at the shiny motor contact area to isolate the frame electrically.

1. Using a sharp hobby knife, cut a thin strip of electrical tape that is slightly larger than the exposed portion of the frame under the motor [17] and longer than the copper bronze clip on the bottom of the motor. (*Kapton tape works well for this also. – ed.*)
2. Apply the tape to the frame, making sure to not cover the mounting holes, and press the tape down well.

## STEP 5: ADD POWER PICKUPS TO THE TRUCKS

Next, we need to add new power pickups to the trucks to improve reliability.

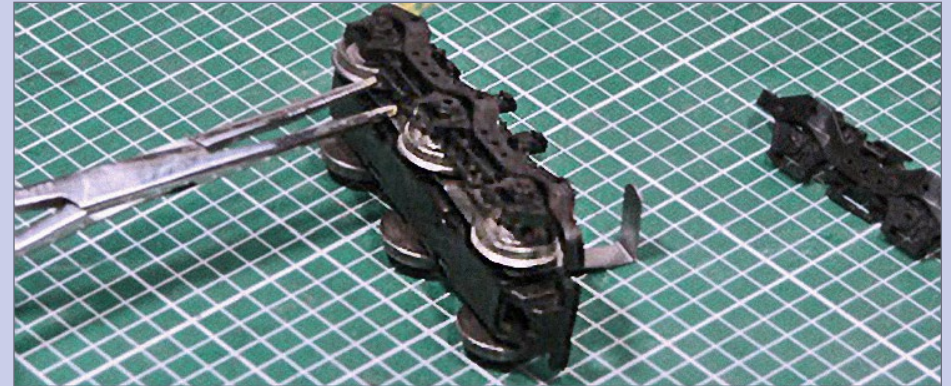

**18a. Remove truck sideframes:** Using a locking hobby clamp (hemostat), gently pry up with even pressure while pulling the side frame away from the truck.

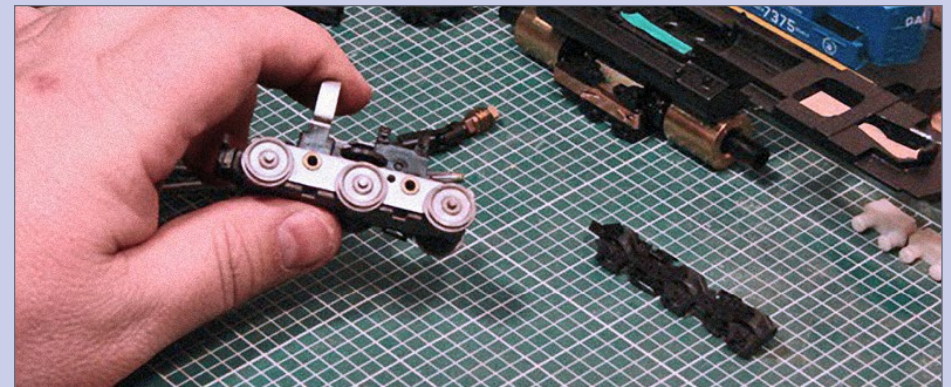

**18b. Success!** The side frame has been removed and the plastic pins are intact.



**STEP 5: ADD POWER PICKUPS TO THE TRUCKS** *CONTINUED ...*

1. Remove the plastic side frame by gently rocking it up and down while pulling it away from the truck. I use a hobby clamp to pry up on both sides of the mounting pins so that there is even pressure. This lessens the chance of breaking the pins [18a, 18b].
2. Remove the metal power bracket from both trucks. I use a rotary tool and cut them off level with the top plate of the truck [19]. Make sure that the two sides of the frame are separate. There must be a gap [20].
3. Clean the area where we are going to solder the new leads with a small file, sanding stick, sand paper or scrape it with a hobby knife [21]. Be careful to not sand the wheels!
  - You may sometimes encounter a painted metal frame that you must to sand for soldering [22].

We want the wire positioned right next to the rivet on the inboard side of the truck [22].

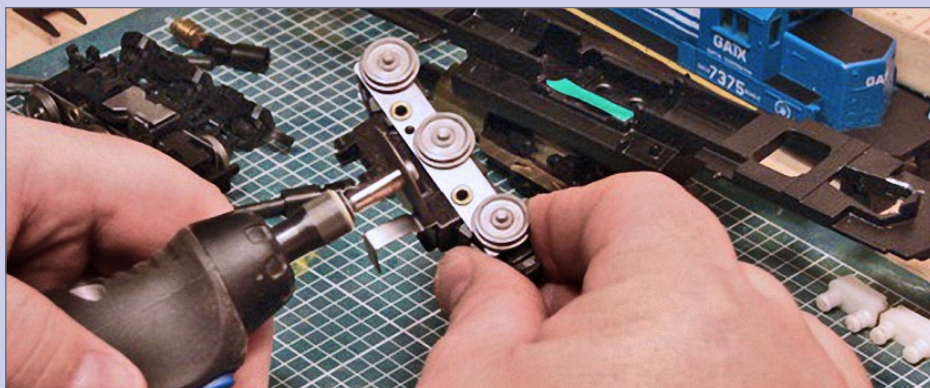

**19. Cut off L bracket:** Use a motor tool with a cutoff disk to cut the metal L bracket off the truck.

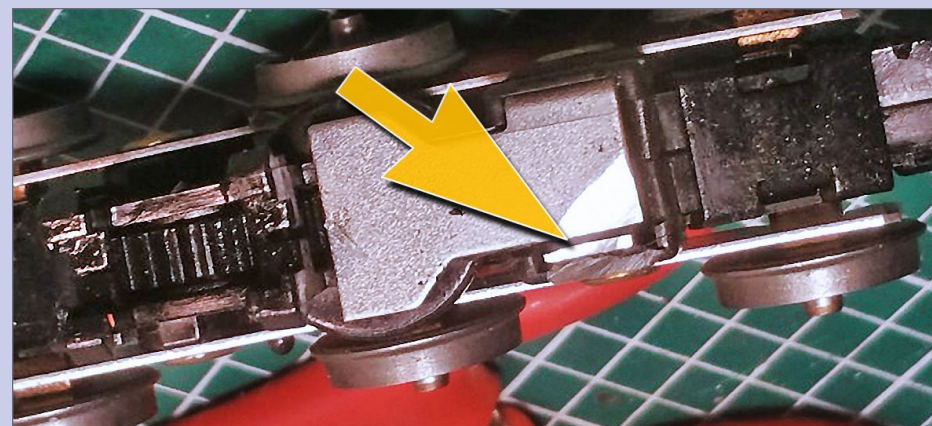

**20. Cut level with top plate:** Cut the bracket level with the top plate of the truck, and make sure there is still a gap.

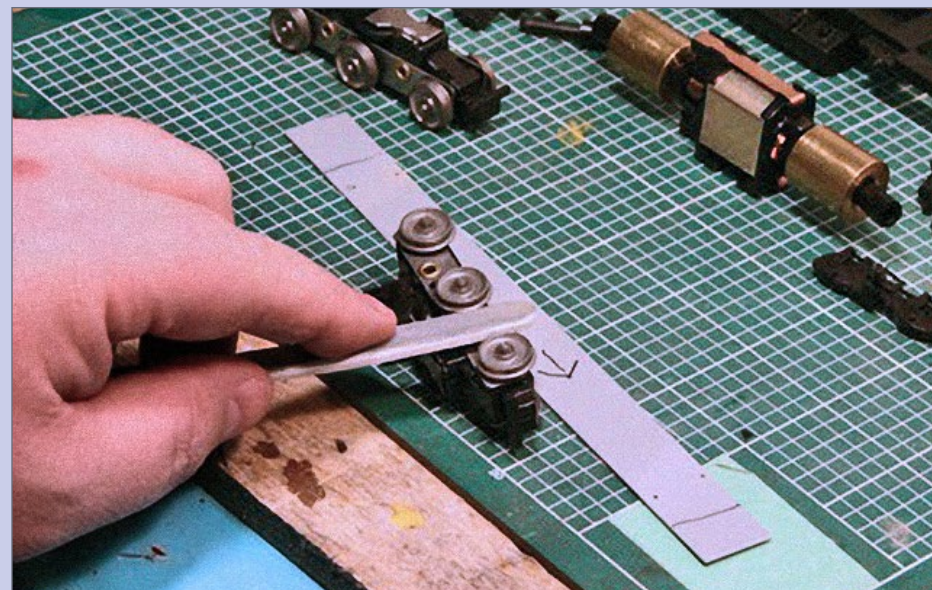

**21. Prep power lead location:** Sand the truck side frame in preparation for soldering on a new power lead wire.

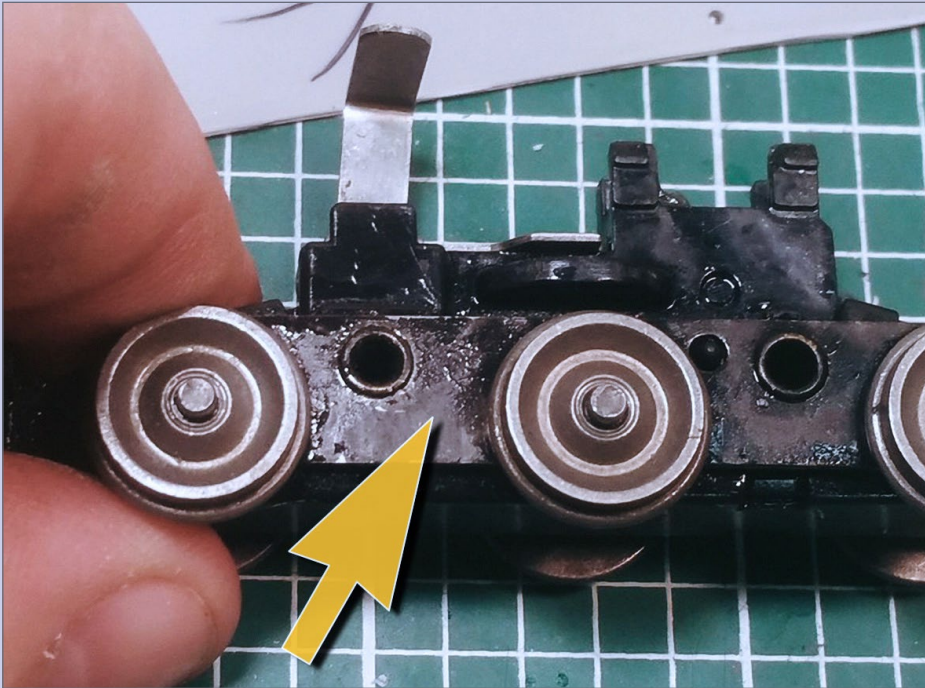

STEP 5: ADD POWER PICKUPS TO THE TRUCKS *CONTINUED ...*

**22. If painted, sand off paint:** You may encounter a painted truck. You need to sand off the paint where the arrow is pointing, so the solder will stick to bare metal.

**VIEW READER  
COMMENTS**

*click here*

Next, we need to solder the feeder wires to each truck.

1. Make four wires 7" long. I use red wires for the right side and black for the left just to help keep from getting the wires crossed. (*You may want to color the end of the red wire near the truck black with a Sharpie marker so you don't see the red through the side frames. – ed.*)
  - Strip the wires about ½" at both ends.
  - Tin all the wires by applying solder to the stripped portions of the wires.
2. Attach the wires to the metal sides of the trucks [23, 24].
  - Use a weight to hold the wire in place for soldering.
3. Solder quickly to avoid melting the truck.
  - If the solder doesn't hold on your first try, let the area cool down and clean it again before attempting a second time.
4. Reassemble the trucks, making sure you press the plastic side frames on without damaging any of the details [25]. Make sure you don't pinch the wires around the truck and side frame pins.

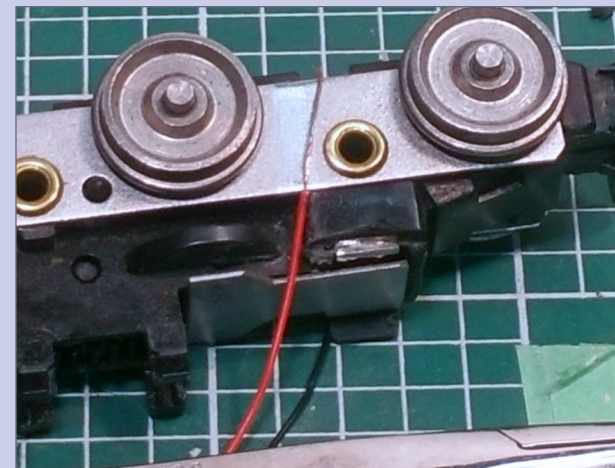

**23. Tinned power lead placement:** Place the tinned wire on the truck's metal plate as shown.

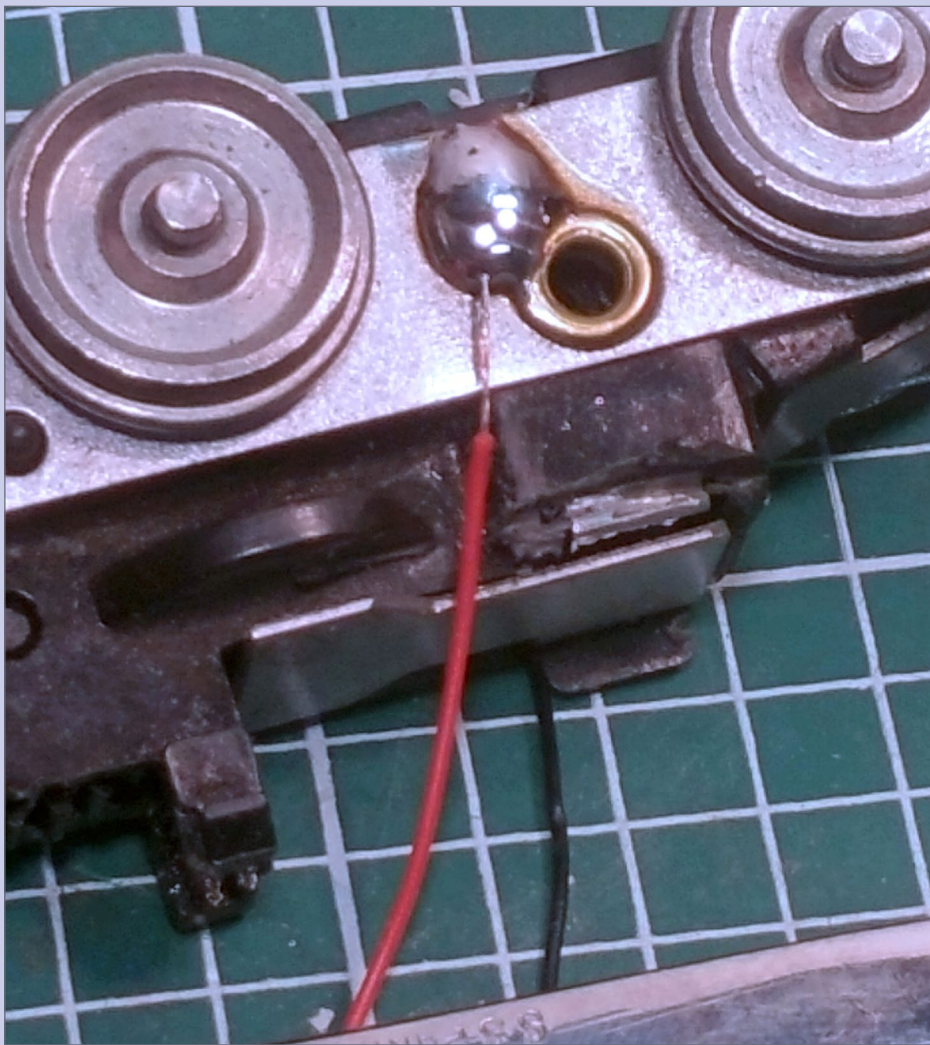

STEP 5: ADD POWER PICKUPS TO THE TRUCKS *CONTINUED ...*

**24. Apply the solder:** Work quickly with the iron to avoid melting the plastic assembly behind the metal plate. (*Less solder works just as well. – ed.*)

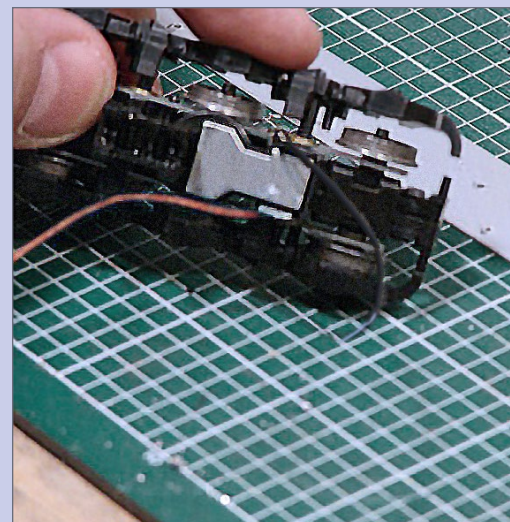

**25. Reinstall side-frames:** Put the side frames back onto the truck by pressing the pins down into their respective holes. Avoid pinching the feed wires with the side frame.

Lubricate the gears inside both trucks.

1. Apply a few drops of oil to the top gear, then roll the truck back and forth to distribute the oil evenly on all the gears [26]. (*Plastic compatible grease works well on the worm gear itself – less likely to migrate away and splatter at high speed. – ed.*)
2. Repeat for the other truck.

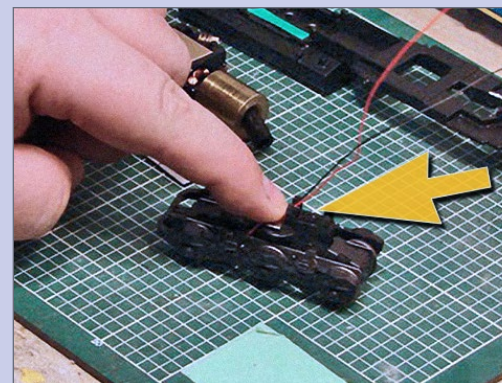

**26. Lubricate truck gears:** Lubricate the top gear (arrow) and then roll the truck back and forth to distribute to all gears.

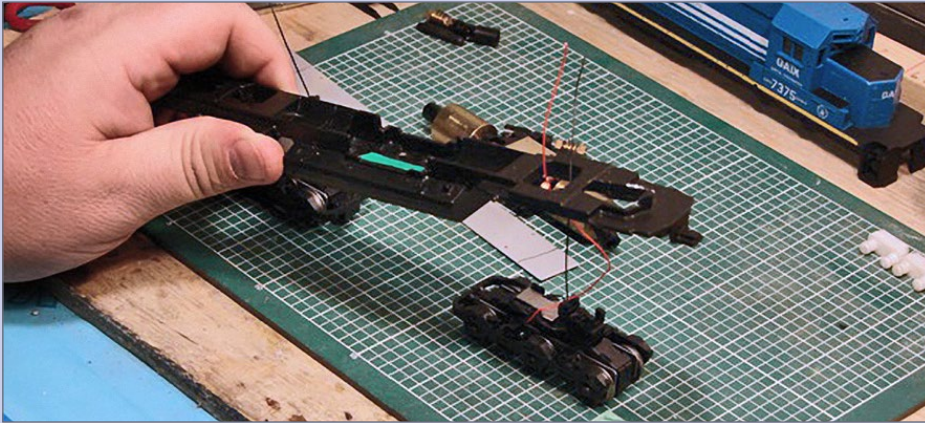

STEP 5: ADD POWER PICKUPS TO THE TRUCKS *CONTINUED ...*

**27. Thread leads through frame:** Starting with the front truck, thread the new feeder wires into the hole closest to the fuel tank. Repeat for the rear truck.

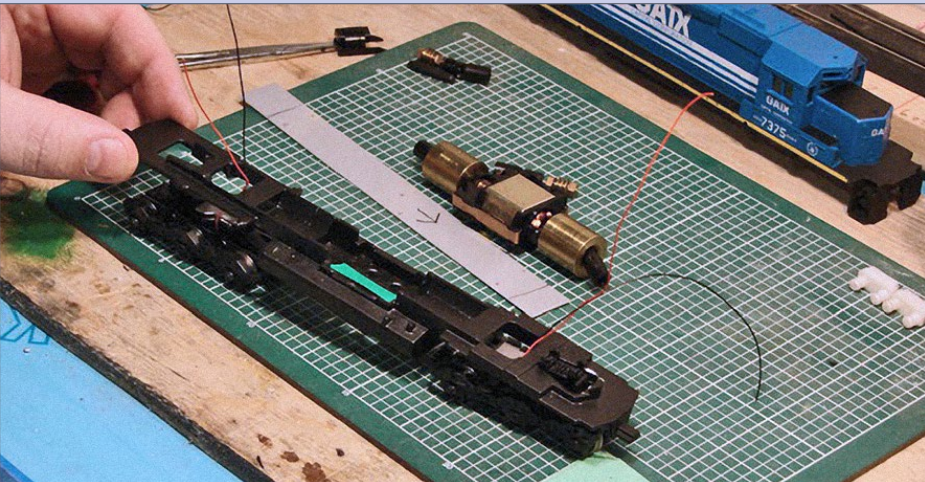

**28. Drop frame onto trucks:** Lower the frame fully down onto the trucks – first the front truck, then the rear truck.

Reinstall the trucks into the frame.

1. Hold the frame in one hand and insert the new feeder wires into the hole closest to the fuel tank for the front truck [27].
2. Lower the frame onto the truck [28], making sure the frame is all the way down and the truck rotates freely.
3. Repeat for the rear truck.

**VIEW READER  
COMMENTS**

*click here*

**When talking to hobby  
vendors, please remember  
to mention MRH.**



## SIMPLER TRUCK WIRING ALTERNATIVE

Maybe you have read the article and thought “Sounds okay but I can’t get the plastic side frames off. I don’t think I am ready to tackle this, it is too much for me, I don’t have the skill to do this.”

I totally understand. When I attempted my first Blue Box conversion I had many of the same thoughts.

I would recommend trying this simplified truck wiring method on the first one or two locomotives you convert.

The drawback to using this method is you do not eliminate the issue of power loss when the trucks tilt vertically.

### The wire shield:

1. There is a slight difference in the wire shield. You only need one hole for the rear truck, and one at the front for the left track wire, the black wire, in [57].
2. Complete the motor soldering.
3. Use a sanding stick to clean the tops of the right-hand metal power hooks that are on the trucks.

### Wiring the decoder.

1. Run a red wire from the rear truck’s hook through the wire shield, over the decoder and back through the wire shield at the front.
  - Solder the red wire to the rear truck.
  - Run the red wire from the decoder through the wire shield at the front.
  - Solder both red wires to the hook on the front truck.

- You must leave some slack or a small loop in these wires under the wire shield so the trucks don’t bind while turning.
2. Run the black wire to the light bracket receptacle and solder it in place. Refer to figures 61c & 61d.
  3. Loop up the remaining wires: blue, white, yellow, green, purple, so they don’t get in the way. Save the wires to use in the second part of this tutorial, “Lighting up your Blue Box locomotives.”
  4. And that’s it! ■

**VIEW READER  
COMMENTS**  
*click here*

**Did you know  
there’s an  
MRH index  
available?**

**CLICK TO FIND OUT MORE**





## STEP 6: MAKING THE WIRE SHIELD

Make a wire shield and base for the decoder.

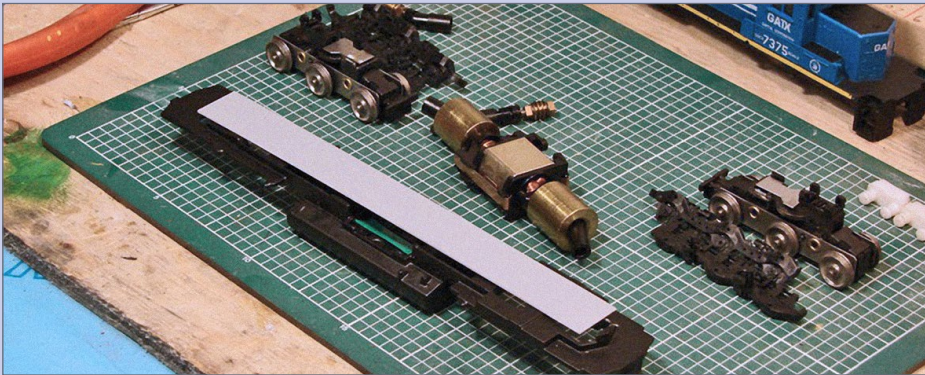

**29. Wire shield:** Make a wire shield out of 0.020" styrene. Measure it to fit the frame. Make it the width of the decoder and no more so it will fit easily inside the shell.

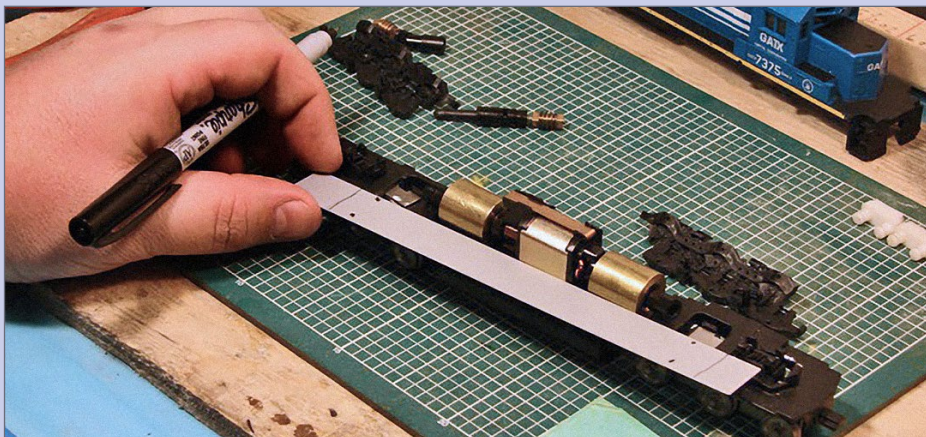

**30. Mark wire locations:** Mark the spots for the wires – two on each end for the truck wires and two over the motor for the motor wire feeds.

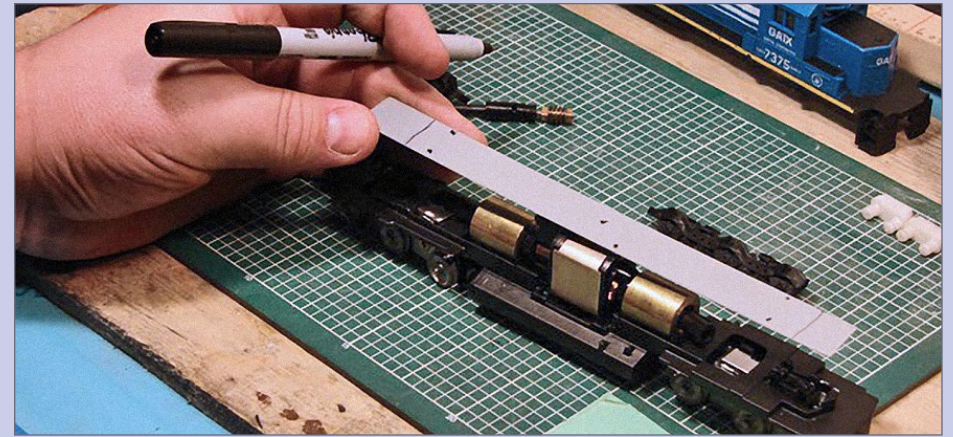

**31. Verify marks are correct:** Hold the piece up against the power chassis to verify correct positioning of the marks for the wires.

1. Cut a piece of 0.020" styrene the width of your decoder. Make sure it can fit inside the body shell. In my case, the width is 0.630". NOTE: I use a paper cutter to make a whole sheet the length of the shield, then cut it into decoder-width strips to avoid having to cut a new one every time I install a decoder.
2. Cut the wire shield to the length of the middle of the worm gear housings. In this case for an SD40-2 unit, the length is 6.5" [29].
3. Remove any burrs from the cut edges with a sanding stick.
4. Hold the wire shield up to the side of the frame and center it between the trucks. Use a felt marker to mark the holes for the wires as shown [30].
5. Set the motor back in place temporarily without the mounts and mark the location for the decoder motor wires as shown in [31].
6. Drill out the holes you marked on the wire shield with a #56 drill in a pin vise [32].



STEP 6: MAKING THE WIRE SHIELD *CONTINUED ...*

7. Remove any burrs from the holes with a sanding board. Also test the holes to make sure the decoder wires thread through without any resistance.
8. Mark the front with an arrow and label all drill holes [33].

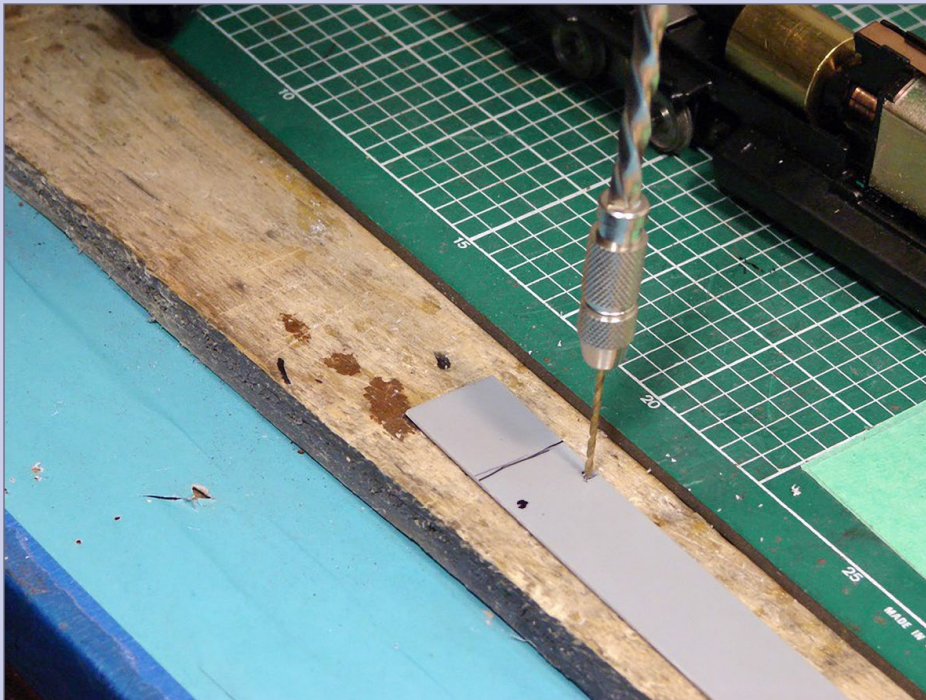

**32. Drill holes:** Using a #56 bit, drill out the marked wire holes.

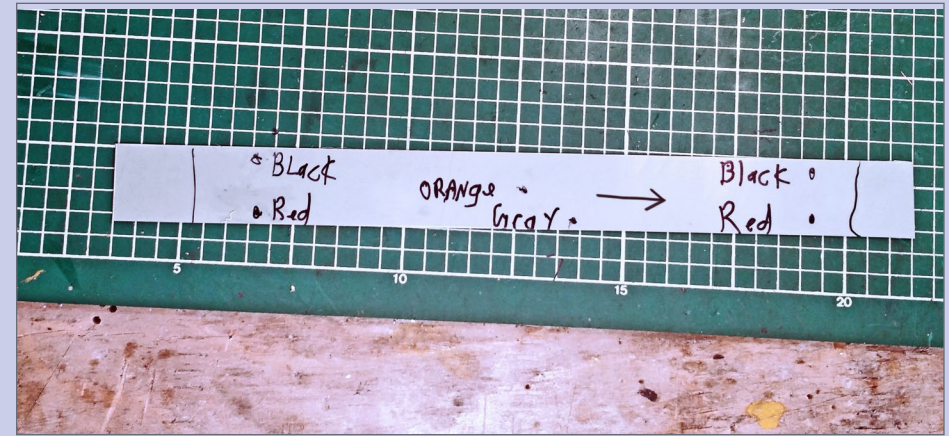

**33. Label the holes:** Label all the wire holes, and mark the front of the shield with an arrow.

# Tell your friends about MRH!

**We depend on word-of-mouth to grow  
... if you don't share us, we don't grow**

**VIEW READER  
COMMENTS**

*click here*





## STEP 7: WIRING THE MOTOR

Time to add wires to the motor.

1. Turn the motor upside down and remove the prongs from the bottom brush retainer clip [34]. File down any burrs or sharp spots.
2. Apply a drop of light oil on each motor bushing where the drive shaft passes through the motor frame [35a, 35b].
3. Place electrical tape under the top brush retainer [36]. This stops a short circuit if the body shell presses the retainer clip against the motor when you place it back on.

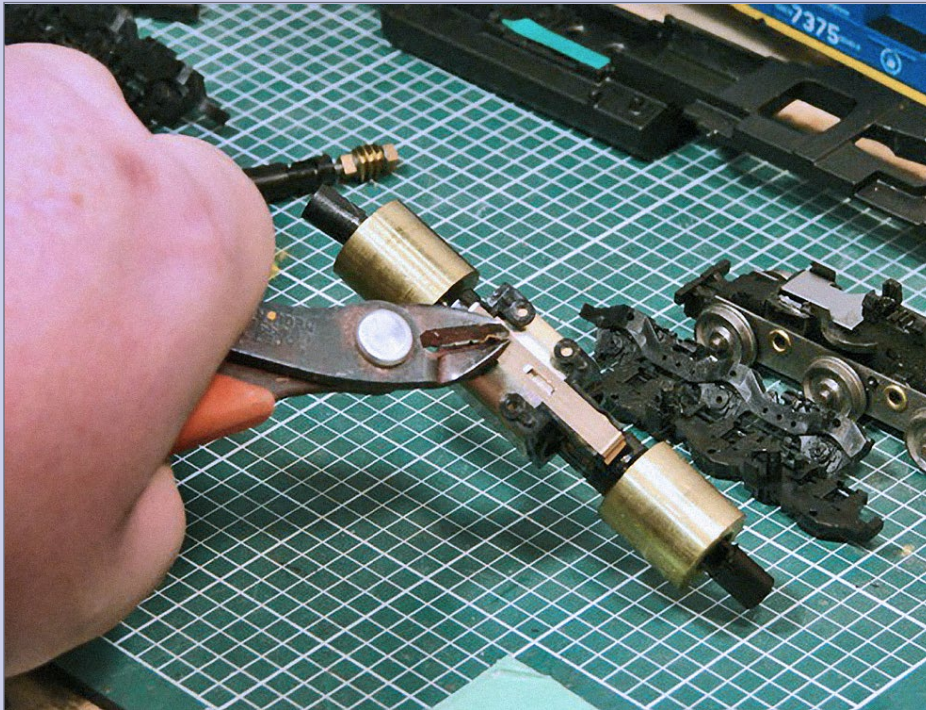

**34. Remove prongs:** Cut off the prongs on the bottom motor clip.

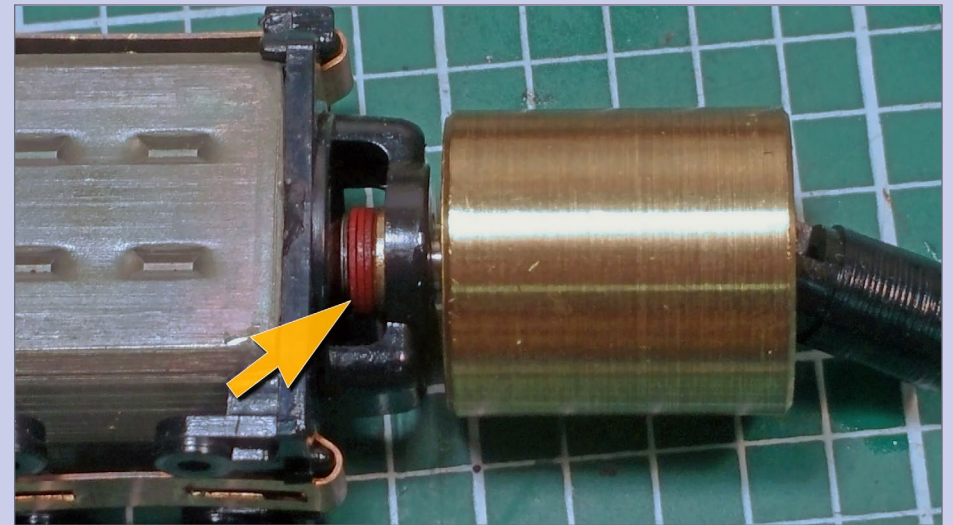
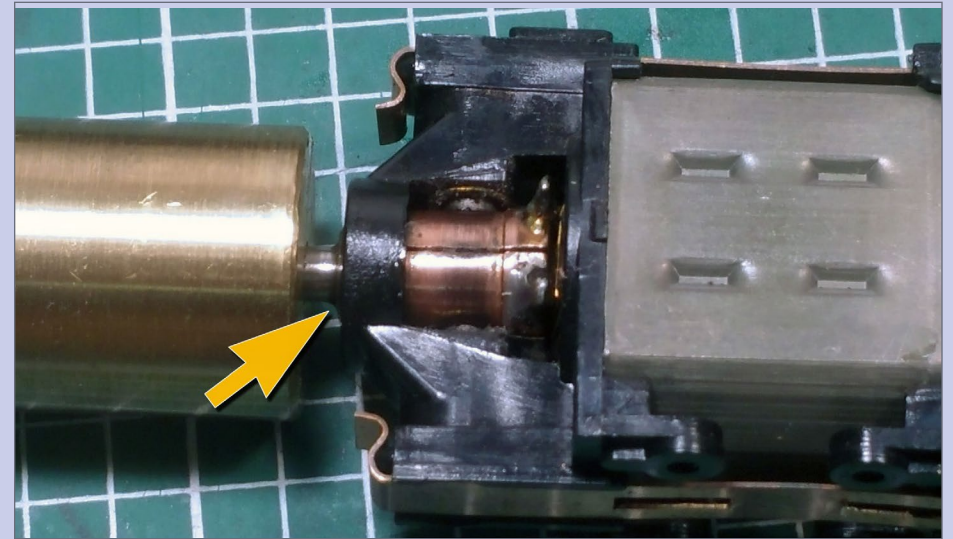

**35a, 35b. Lube motor bearings:** Lubricate the metal motor bearings on both ends with a drop of oil.

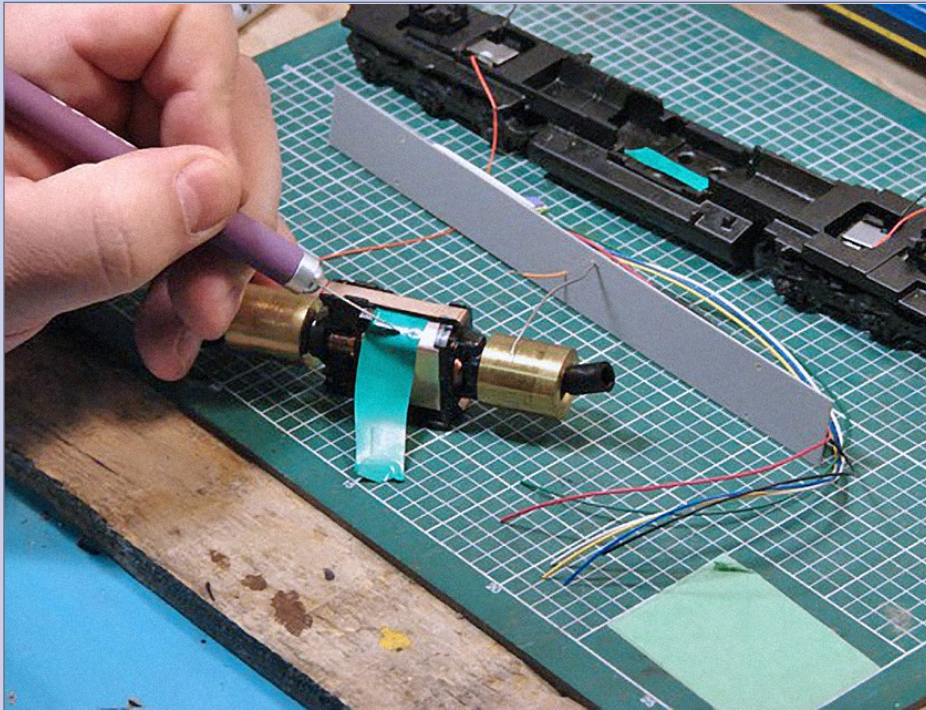

STEP 7: WIRING THE MOTOR *CONTINUED ...*

**36. Insulate motor top:** Apply some insulating electrical tape on each side of the top motor clip.

**VIEW READER  
COMMENTS**

*click here*

## STEP 8: PREPPING THE DECODER

To protect the decoder from accidental short circuits you need to cover it.

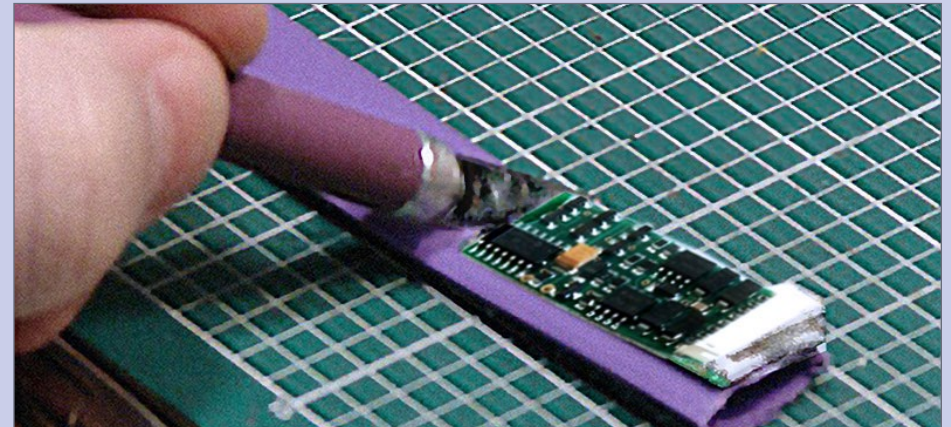

**37. Cut 1/2" shrink tubing:** Using the decoder as a guide, cut some 1/2" shrink tubing to length.

1. Place the decoder on top of a piece of 1/2" shrink tube. Using the decoder as a guide, cut a length of shrink tube slightly longer than the decoder [37].
2. Attach the wiring harness.
  - Line up the key on the harness with the slot on the decoder [38].
  - Firmly press the harness into the decoder [39].
3. Place the 1/2" shrink tube over the decoder and make sure to cover the solder pads on the underside [40].

Next, we need to shrink the tubing.



## STEP 7: WIRING THE MOTOR CONTINUED ...

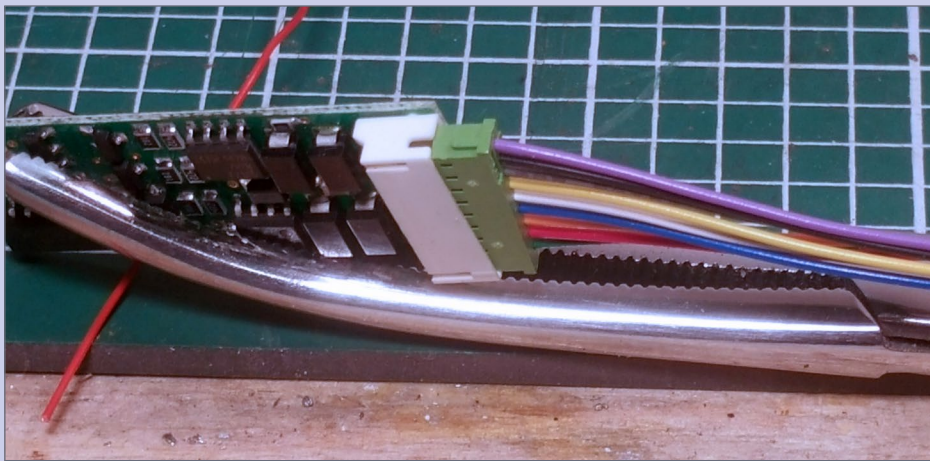

**38. Align plug:** Line up the wiring harness key.

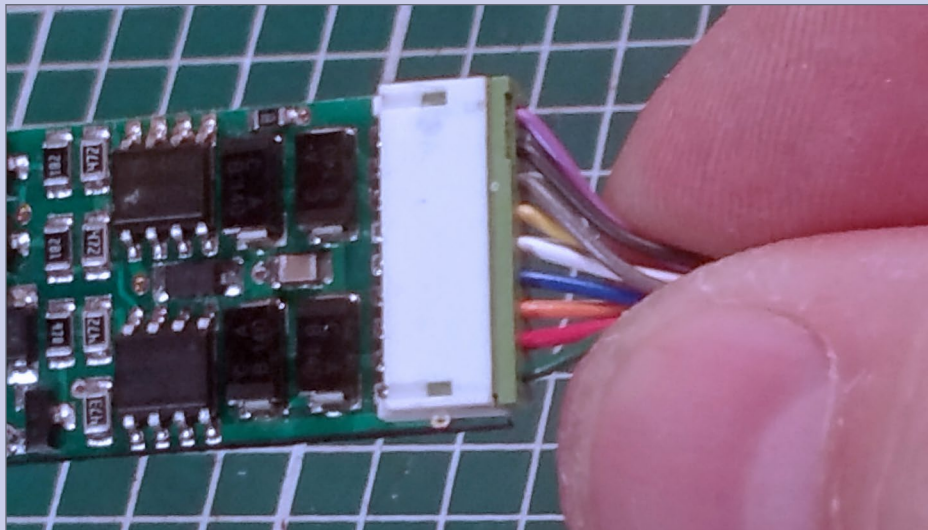

**39. Press in plug:** Press the wiring harness in place until it's firmly seated.

**WARNING!** A heat gun is *NOT* the same as a hair dryer! I'm talking here about a heat gun used for construction work – it can melt plastic in seconds and can give you nasty burns if you're not careful! You can also cause damage to the decoder by heating it up too much if you don't use care. Remove all plastic from the area and hold the heat gun at least 18" away to start with.

1. Heat gun (if you don't own a heat gun, see below.)
  - Grab the decoder with some pliers to avoid burning your hand. Holding the heat gun at least 18 inches away, waive it back and forth on both sides of the shrink tape until it starts to contract [41]. As soon as you start seeing the components stick up, *stop!*
2. Barrel of soldering iron (alternate to a heat gun.)
  - Using the barrel of your soldering iron, rub the shrink tube *very* lightly. *Never* stop moving the soldering iron! Run the barrel of the soldering iron over both sides of the decoder [42] but *do not touch* the edges of the decoder.

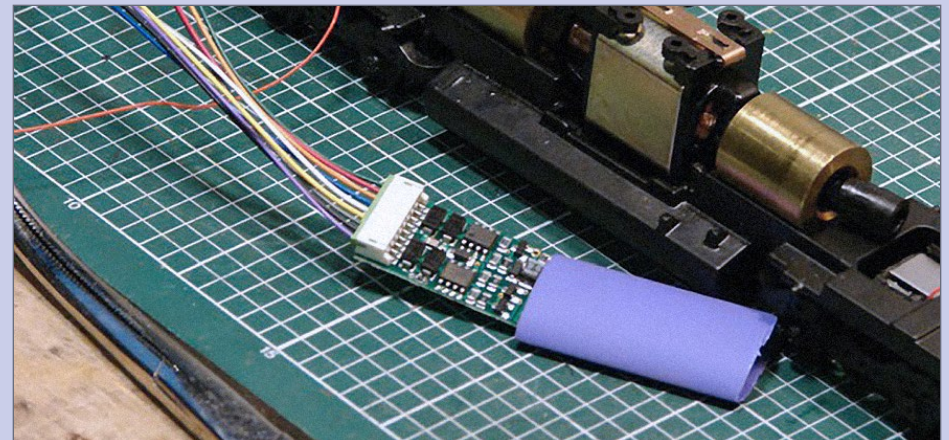

**40. Insulate decoder:** Slip the shrink tubing over the decoder.



## STEP 8: PREPARING THE DECODER

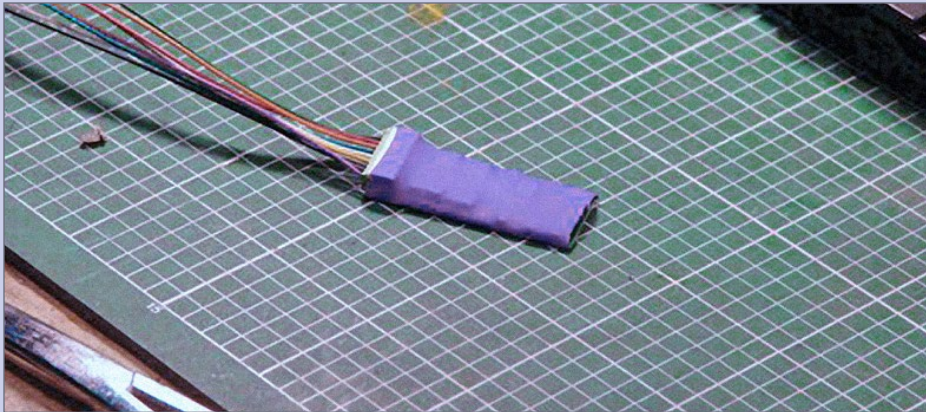

**41. Shrink tubing (heat gun):** Heat the shrink tubing carefully with a heat gun to shrink it up.

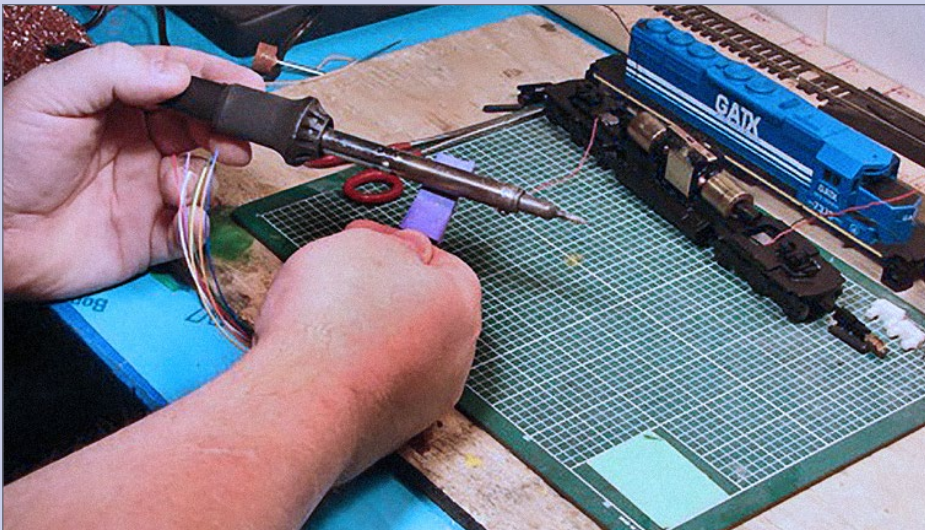

**42. Shrink tubing (soldering iron):** Alternatively, you can shrink the tubing by gently whipping it against the barrel of a hot soldering iron.

## STEP 9: DETERMINE DECODER WIRING METHOD

Get out the installation manual. I show the diagram from the NCE D13J manual here [43].

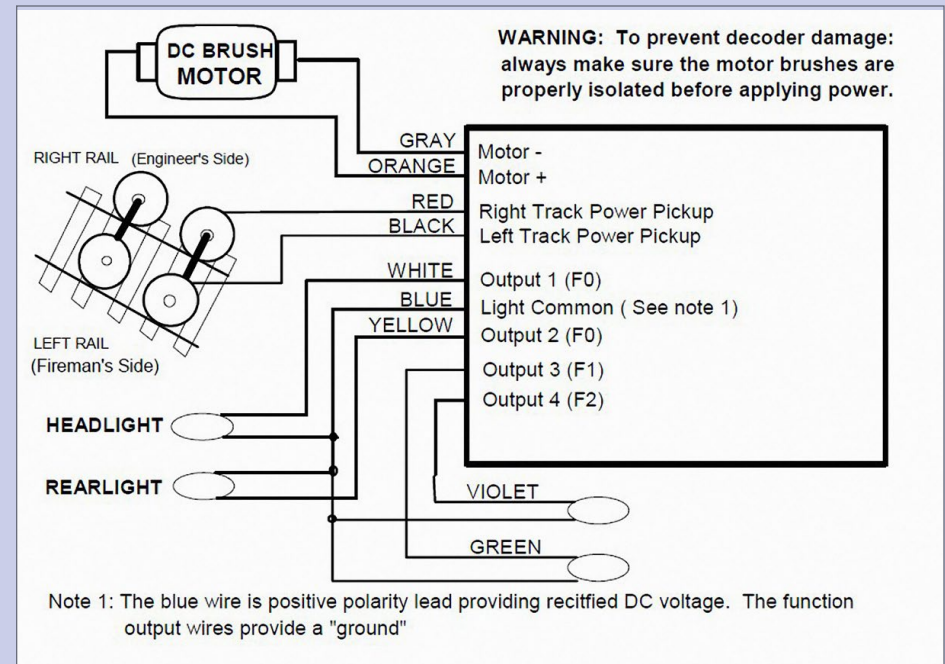

**43. Decoder wiring diagram:** Wiring instructions from the NCE D13J decoder manual.

**VIEW READER  
COMMENTS**

*click here*



STEP 9: DETERMINE DECODER WIRING METHOD *CONTINUED ...***Wiring considerations**

You need to decide what you want this loco decoder to do.

The four wires highlighted in the diagram [43] (red, black, orange, and gray) are the bare minimum needed for a locomotive to run on a DCC powered layout.

In part 2: *Bringing light to your Blue Box Locomotives*, I will show how to install LED lighting for the headlights and number boards. If this is of interest to you, keep the decoder's blue, yellow, white and green wires intact.

On most decoders there is also a purple wire (used for function 2), and in my case I won't need it. To save clutter in the body shell, I have clipped this wire off about 3/4" from the plug.

I do like to leave enough wire that I can re-attach something to it later in case I decide to add something, like a Mars light.

**Decoder placement**

Many Athearn Blue Box locomotives have a weight built into the shell directly under the dynamic brake housing. This can interfere with mounting the decoder to the top of the motor.

Test your installation's fit before trimming any wires! This will stop you from cursing my name and then having to solder extensions onto all the wires because the decoder won't fit in your chosen location.

My recommendation for placement in this instance is just behind the cab and short hood. Another option is far to the rear under the radiators [44a, 44b].

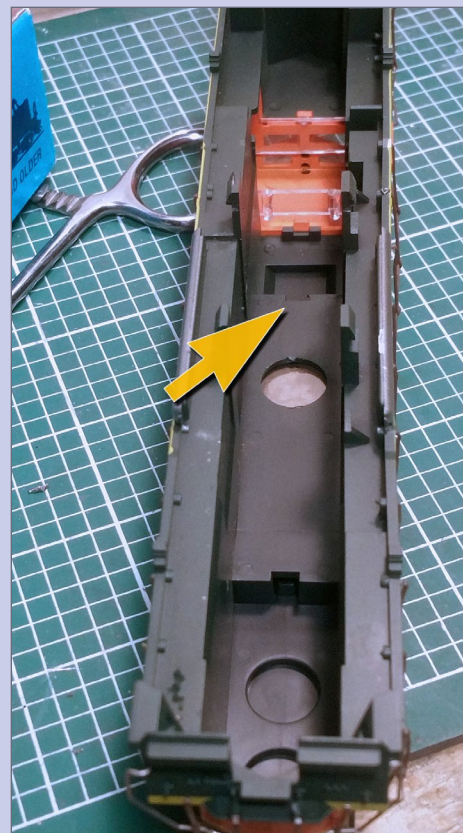

**44a. Behind cab:** One good location for a decoder is just behind the cab area but in front of the dynamic brake (see arrow).

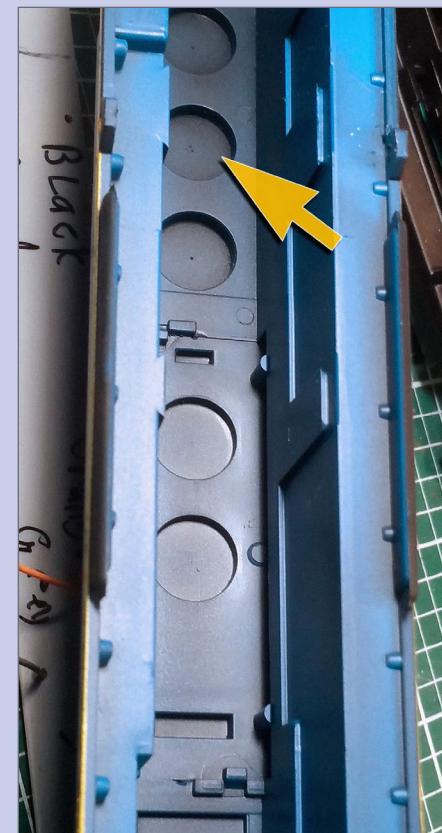

**44b. Under rear fans:** Another good decoder location is to the rear under the radiator fans (see arrow).

**VIEW READER  
COMMENTS**

*click here*





## STEP 10: WIRING THE DECODER

It's now time to wire the decoder into the locomotive.  
**TIP:** When cutting the wire to fit, always leave a little extra.

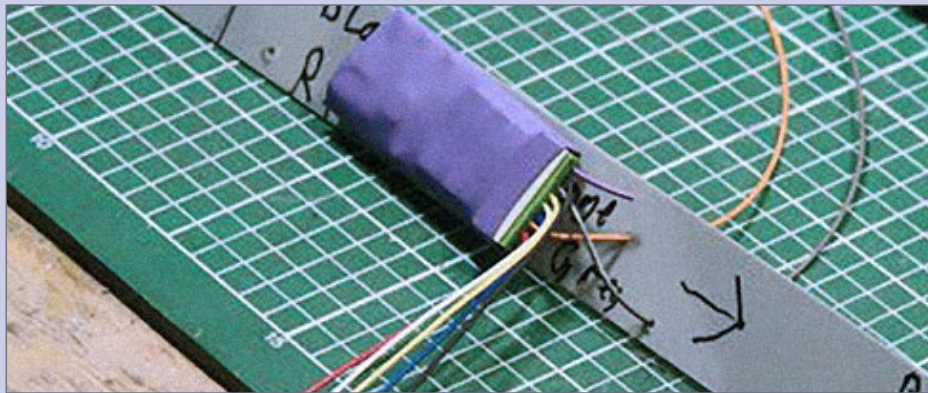

**45. Fix decoder in place:** Once you know the best location for the decoder, fix it in place to the shield with some double-stick foam tape.

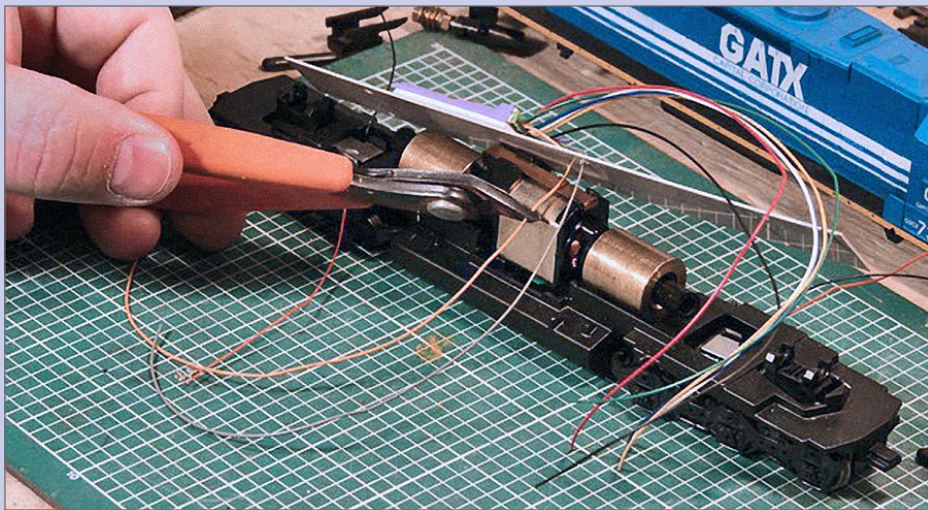

**46. Trim orange wire:** Cut the orange wire to about 1-1/4" long.

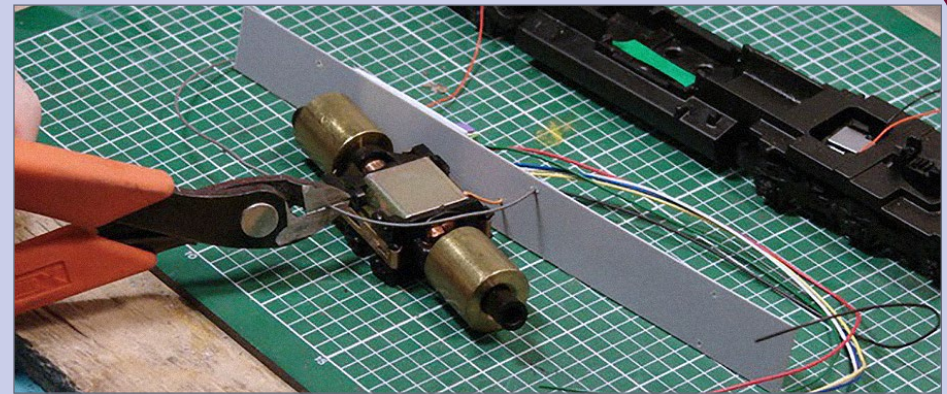

**47. Trim gray wire:** Cut the gray wire so it is long enough to reach the bottom of the motor.

1. Cut and place a piece of double-sided foam tape to the bottom of the decoder and stick it to the styrene shield in the location you determined back in step 9 [45]. Trim off any tape that sticks past the edges of the shield.
2. Cut the orange wire so there is at least 1-1/4" of wire sticking out [46]. It may seem like a lot since the motor top is right under the shield, but remember you may need to move the wire shield for servicing later.
3. Lay the motor on your work mat with the front pointed to the right.
4. Place the wire shield on top of the motor with the gray wire running around the motor. Trim the gray wire to length to reach the bottom of the motor with some excess [47].
5. Strip the ends of both motor wires.
6. There are many ways to strip the insulation off the wires –some very fine wire strippers can do 30AWG wire, or with care you can use a #11 blade to cut around the wire.
7. Set the motor upside down.

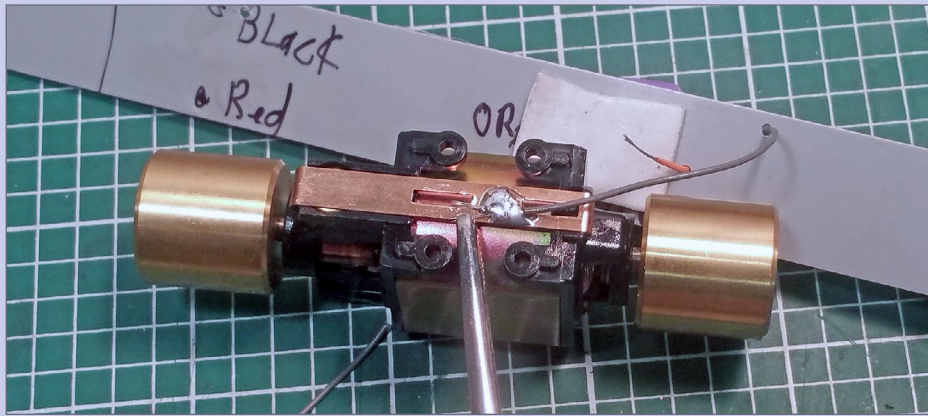

STEP 10: WIRING THE DECODER *CONTINUE ...*

**48. Solder gray wire:** Solder the gray wire to the bottom retainer clip on the motor.

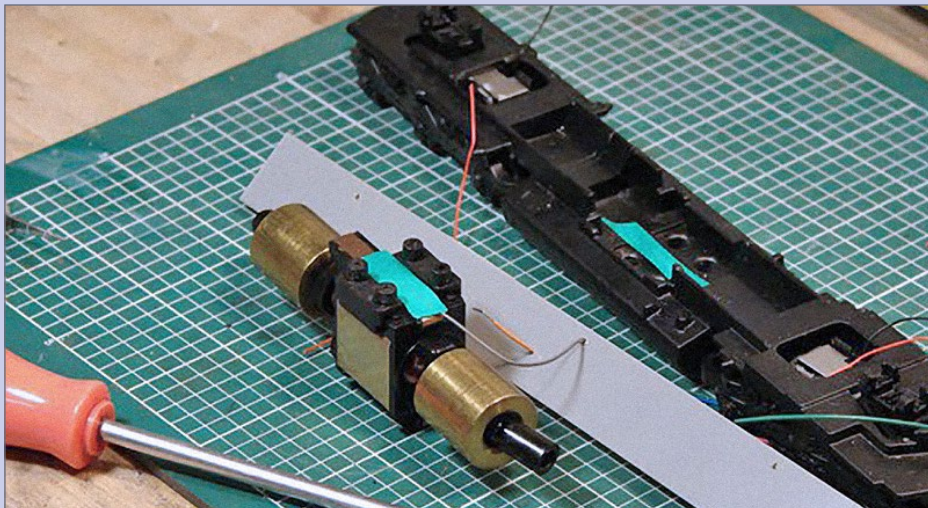

**49. Insulate bottom motor clip:** Cover the soldered area on the bottom of the motor with electrical tape to keep the motor isolated from the frame.

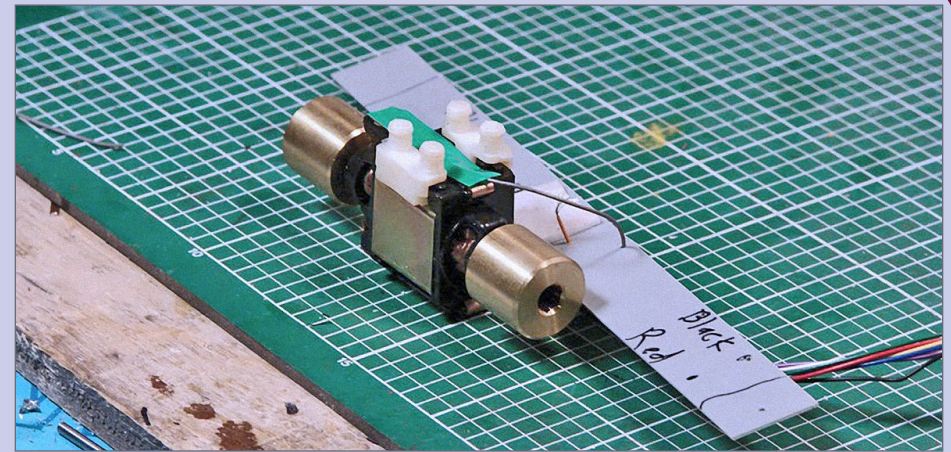

**50. Replace mounts:** Put the motor mounts back on the motor.

8. Solder the gray wire to the middle of the brush retainer making sure the wire points to the right so it will pass between the motor mounts. I use a hobby clamp to hold the wire in place for the soldering [48].
9. Cover the soldered area with a piece of electrical tape [49] (*or Kapton tape - ed.*)
10. Replace the motor mounts [50] and install the motor in the frame [51]. Press down while rocking the motor from side to side until it is fully seated.
  - Make sure the gray wire does not get pinched!
11. Place some insulating tape on the top of the motor alongside the top motor clip as insurance against shorts. Solder the orange wire to the top motor brush retainer [52].
12. Place one or two pieces of foam tape under the wire shield where it will sit on the motor [52] but do not remove the tape backing yet. Trim the foam tape so it doesn't overhang the edges of the wire shield, then test fit it on top of the motor [53].

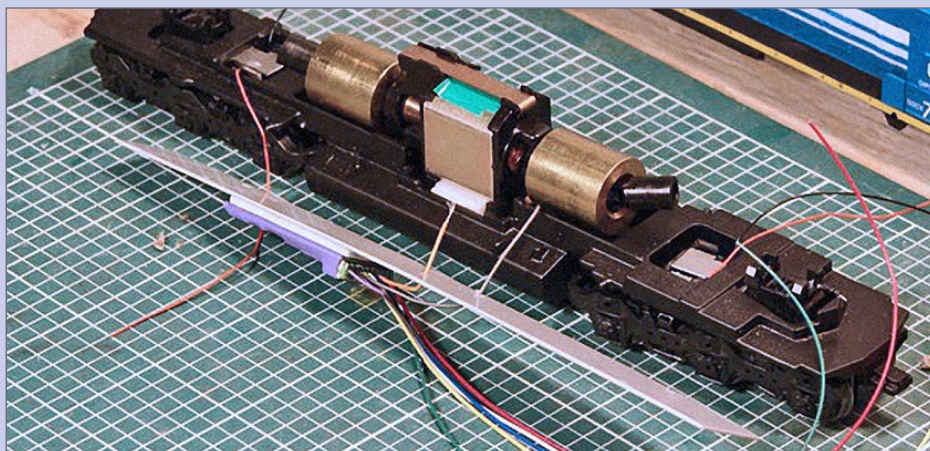

STEP 10: WIRING THE DECODER *CONTINUED ...*

**51. Reinstall motor:** Install the motor back into the loco frame.

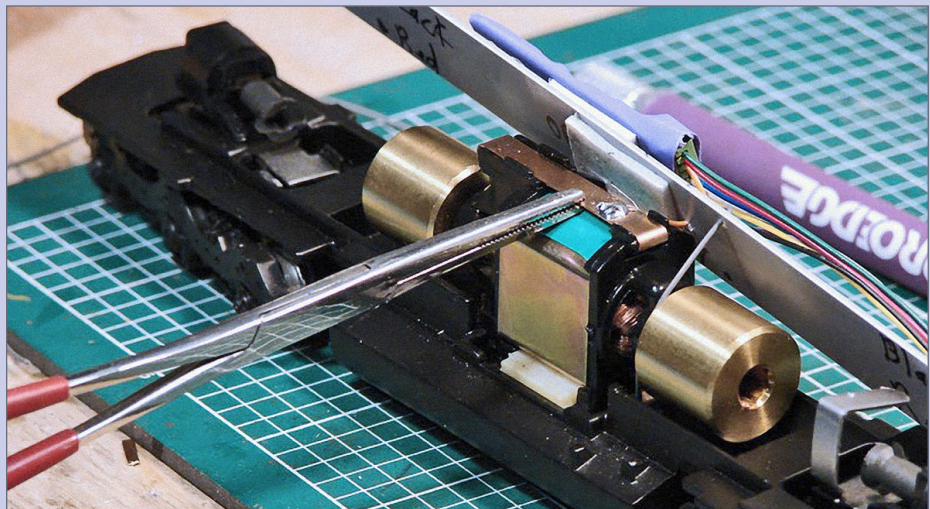

**52. Solder orange wire:** Solder the orange wire to the top motor clip. Note the double-stick foam tape applied to the underside of the shield.

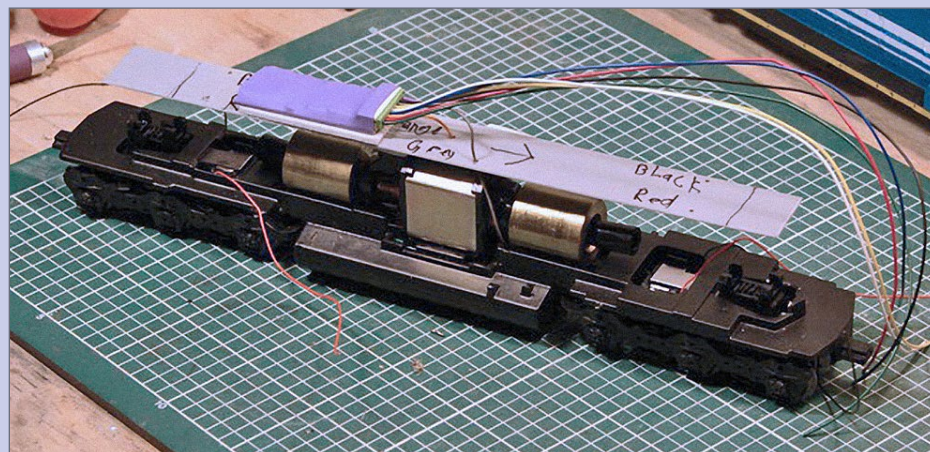

**53. Test fit shield:** Without taking the backing paper off the foam tape, check the fit by temporarily positioning the shield on top of the motor.

**VIEW READER  
COMMENTS**  
*click here*

**When talking to hobby  
vendors, please remember  
to mention MRH.**



## STEP 11: REINSTALL AND WIRE THE TRUCKS

On to reinstalling and wiring the trucks.

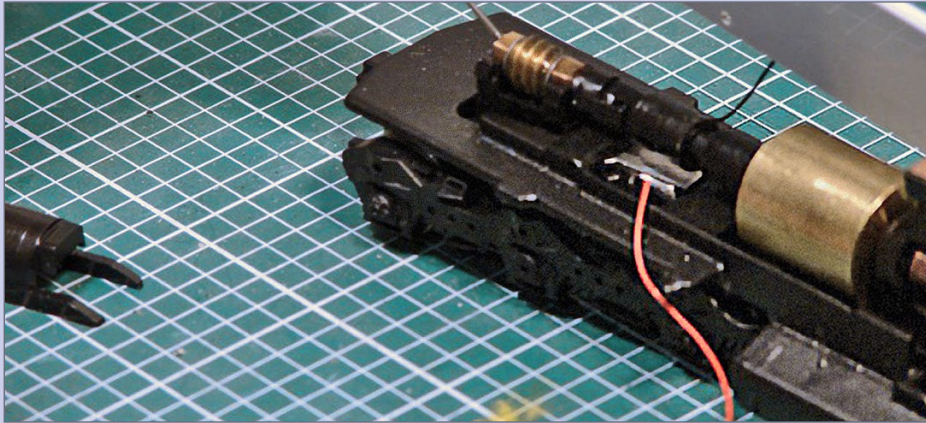

**54. Reinstall worm gears:** Install the worm gear on the truck and apply a drop of oil to the worm gear and each of the square worm gear bearings. Repeat for the other truck.

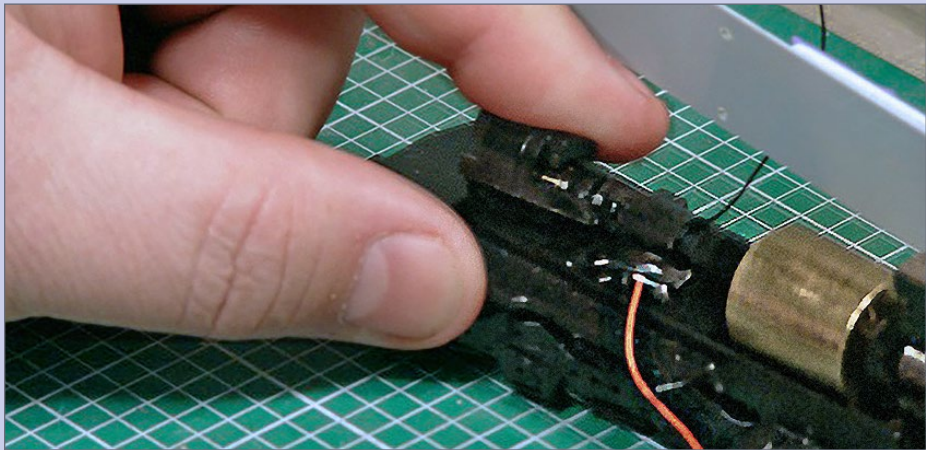

**55. Replace worm gear covers:** Snap the worm gear cover clip on. Repeat for the other truck.

1. Reinstall each worm gear and drive shaft on each truck and apply a dot of oil to the worm gear and bearings [54].
  - To line up the spline in the coupling, rotate the motor by spinning one of the flywheels.
2. Reinstall both worm gear cover clips [55].
3. Feed all four truck wires up through the wire shield. Peel the backing off the foam tape you attached to the bottom of the wire shield and press the wire shield in place on the top of the motor [56].
4. Test fit the two black leads to the decoder black lead. Trim the black lead to length and strip the end. Place 1/2" of shrink tube over the black decoder lead.
5. Twist the black truck leads and the black decoder lead together and solder the connection.
6. Slide the shrink tube over the connection and shrink the tubing.
7. Repeat for the red power leads.

The decoder is now installed and wired [57]. We will check the installation to make sure it's good, then we'll tidy things up and put the shell back on.

**VIEW READER  
COMMENTS**

*click here*



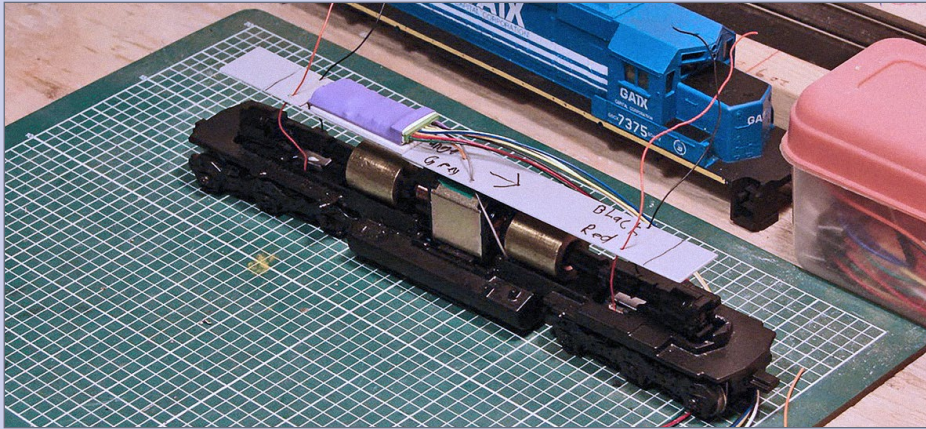

STEP 11: REINSTALL AND WIRE THE TRUCKS *CONTINUED ...*

**56. Thread feeds through shield:** Thread the red and black truck wire feeds through the holes in the shield.

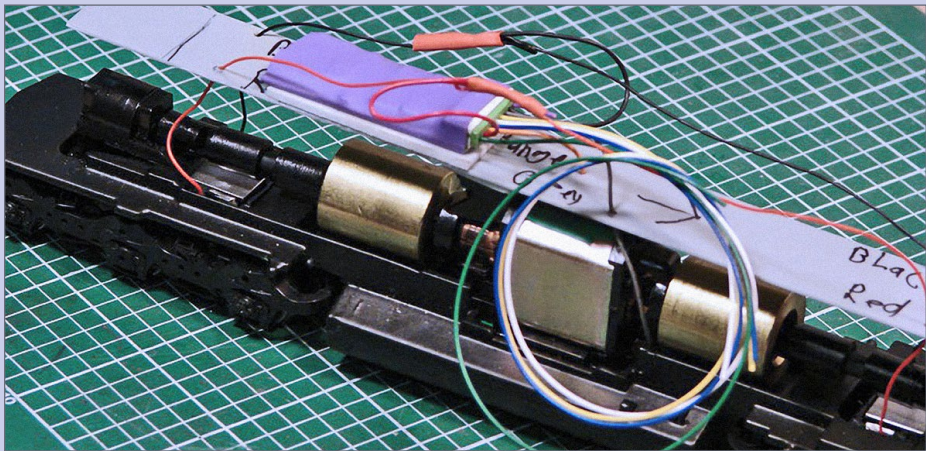

**57. Solder to decoder leads:** Thread some shrink tubing on the black and red decoder leads, and then solder the corresponding truck feeds to the same color decoder wire. Shrink the tubing over the bare solder joints to insulate them.

## STEP 12: CHECK THE INSTALLATION

Before tidying up the wires and putting the shell back on, let's test the installation to make sure it's correct.



**58. Test for shorts:** Using the connectivity setting on a multimeter, check for shorts between the wheels and the motor housing, as well as between the wheels on the left and right sides.

★★★★★  
RATE THIS ARTICLE



STEP 12: CHECK THE INSTALLATION *CONTINUED ...*

**59. Set loco address:** Having verified there are no shorts, put the loco on the programming track and set its address.

1. Using a multimeter, set it for continuity and check between the side of the motor and the right/left wheels [58]. You want zero continuity (no connection) which with my meter means no audible sound. If I get a sound, I have a short.
2. Test between the left and right wheels. Again you want zero continuity (no connection).
3. Move the locomotive to your DCC programming track and read CV 8. For an NCE decoder, it should return a value of 11 (NCE's assigned manufacturer number).
4. Next, program the locomotive's new address [59].

5. Place locomotive on a regular track. Gently increase the throttle slowly until the unit starts to move. Increase the speed to maximum [60].
6. Press stop, then reverse the locomotive's direction and repeat the process.
7. The loco should move without making any loud clicking or grinding noises.



**60. Test run loco:** Once the loco address has been set, put the loco on some normal running trackage and give it a try. Make sure it runs freely with no binds or abnormal sounds.



## STEP 13: FINISHING UP

With the installation tested, it's time to tidy up and put the shell back on.



**61. Tidy up:** Tidy up any loose wires and gently place the shell onto the body, making sure to keep any wires from getting pinched between the shell, shield, and the frame.

1. Trim any unused wires down to about an inch or so in length. Remember, if you plan to install LED lights and number boards (as we will do in part 2), you need to keep the blue, white, yellow, and green wires intact. Fold them over and make them into a loose knot for now [61].
2. Gently place the body shell on over the completed chassis [62].
  - Make sure you don't catch any wires with the shell retainers or pinch any wires between the body shell and the frame. This is the leading cause of destroyed decoders during a conversion.



**62. Apply the shell:** Once you're sure no wires are caught or pinched, go ahead and slide the shell down onto the frame until the latches catch.

- Check that the body is sitting properly on the frame and that the shell fits properly onto the shell retainer pins or down into the shell retainer slots [63].
3. Test run the unit again and listen for noises.
    - If you placed your decoder directly on top of the motor it is possible that the shell dynamic brake weight is pushing the motor into the frame.
    - If you find any issues, remove the body shell and see if you can spot the binding. Fix the issue and put the body shell back on.
    - As soon as the loco runs normally without any bad noises, you are set to go!
  4. Break in the loco by running it on a loop at 1/3 speed for 15 minutes. Then stop it and run in the other direction for another 15 minutes.



STEP 13: FINISHING UP *CONTINUED* ...

- Increase the speed up to half and run it again, reversing directions every 15 minutes.
  - You will notice that the locomotive will start moving on lower power settings as it breaks in.
5. Enjoy!



**63. Finished:** With the shell snapped in place, time to go enjoy your new DCC equipped Blue Box loco!

Watch next month's *Model Railroad Hobbyist* for part 2: Installing LEDs in your Blue Box loco. ✓

## LES GREEN

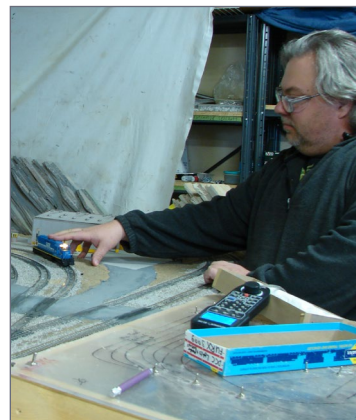

Les had a few locomotives and some track as a kid but they didn't last long and Les moved on to other interests.

Les worked in the autobody and towing industries for years until one day he met his friend Scott.

Scott showed Les his 9' x 15' layout and Les became hooked again on the hobby, helping Scott expand his layout.

Before long, Les started an HO 6 by 10-foot switching yard with a locomotive service and fueling area. He has continued to expand it with additional benchwork and more levels.

Over his years in the hobby, Les has developed an interest modeling CP and CN diesels, although he does harbor a secret love for the AT&SF. He has also developed an interest in doing DCC conversions.

Les finds his autobody experience handy when it comes to working on plastic models and painting them.

Les is currently installing Tortoise switch machines on his layout and controlling them with an Arduino Mega and relays, and becoming conversant with writing code in C++.

Les' other hobbies include 1:24 scale model building, motorcycle restoration and riding, wood working, metal working, and working on full sized (not model) cars and trucks, both mechanically and doing body work. ■



# DISCOVER TRAINMASTERS.TV

Helping you  
achieve your  
hobby dreams



Brought to  
you by



[CLICK HERE](#)

Navigate the  
video archive >>



# YES ... IT'S A MODEL



Model Railroad Hobbyist | October 2018 | #104

compiled by **JOE FUGATE**



1. Another empty boxcar being spotted at door #9, to be loaded with vegetarian dog food, all in a day's work for this Alco S2 #4 and its crew.

Ray O'Neill took this photo on his HO UK exhibition layout he has named "End of the spur." The track is Peco code 75 which has been weathered, and ground cover added. All the buildings are scratch-built using various plastic components. The S2 is a Bachmann Trains model, and the boxcars are Athearn RTR.

[▶ MRH'S MONTHLY PHOTO ALBUM](#)





2. Rutland Mikado #33 is passing under the River Street bridge, as it departs Rutland, Vermont, and heads for Bellows Falls, Vermont. The locomotive is an HO Broadway Limited Imports model custom-painted and decaled. Greg Wiggins built the bridge using Rix Products components, with custom-made bridge piers created from a master rubber mold and poured resin. The houses on the hill are City Classics company house kits. Each house has been modified with the addition of porches, rain gutters, window shutters, and various manufacturers' roof shingles. The sky backdrop is by Trackage Scenery.

## \$ GET PAID FOR YOUR PHOTO

We pay \$40 per photo we publish. If you would like to get your modeling in our photo feature, just start posting your photos on the *MRH* website, especially in the Weekly Photo Fun thread created each week.

See [mrhmag.com/help](http://mrhmag.com/help) for more on how to post an image. You need to be an *MRH* subscriber to post photos to our website, and becoming a subscriber is free, [just fill out this form here.](#) ■

**VIEW READER  
COMMENTS**

*click here*







RATE THIS ARTICLE

We're all familiar with "good enough" kitbashing, and even scratch-building to make our models as accurate as possible, but I'd wager few of us have the fortitude to go through that effort to produce the exact same model or part, over and over again.

That's where resin casting comes in – you make just one master of what you want, and then duplicate it.

Simple, right? Well, actually, yes. And no.

Like other unfairly intimidating aspects of the hobby, I put off even trying resin casting but discovered it's surprisingly easy to get started and get good results – but you'll also spend a long time practicing and honing your skills as your models become more complicated.

I'm new at this myself and certainly no expert, but if you follow along I'll show you how simple it is to add resin casting to your arsenal of modeling skills.

The main reason I wanted to learn how to do resin casting was so I could duplicate a set of wonderfully detailed bridge girders based on photos I took of an overpass at the north end of Wethersfield, CT. The New Haven Railroad's Connecticut Valley Line enters the north end of Wethersfield by passing under the Route 15 highway overpass.

On my model of this line, the overpass provides the perfect way to hide a hole through the backdrop into the Hartford staging yard, so I had to have a model of it. And it *had* to include those distinctive girders.



## FIRST TIME RESIN CASTING

Model Railroad Hobbyist | October 2018 | #104

**CHRIS ADAMS** finds casting a bridge girder leads to learning a new skill ...

**ONE OF THE JOYS – AND CHALLENGES – OF TRYING TO** model a prototype faithfully is confronting how often your reach exceeds your grasp. You see something in real life you want/need to include on your layout, and there's no available model that's even close.

1. I started with the Shapeways parts as masters, which I primed with Tamiya Fine Surface Primer. Here I'm trying to arrange them as efficiently as possible for making the mold box. I determined that about 8.5" across and 4.5" front to back would make a good footprint/base.





## FIRST TIME RESIN CASTING | 3

While there are no photos of the bridge itself during my late-1940s era, the original bridge girders are still there today. So my friend Mike Redden used my photos and Shapeways to make a master of one course of the girders.

“All” I had to do was make duplicates for the other courses ....



2. To make the mold box itself, I transferred my measurements to a piece of foamcore, cut out the base, and then cut the sides about 5/8" high. This would account for the thickness of the base (I glued the sides to the edges of the base rather than on top), plus the thickness of the parts, and still allow 1/8" to 1/4" of rubber on top to cover everything adequately. In addition to hot-gluing the sides to the edge of the base and to each other, I ran a bead of glue inside each joint to ensure that the box would not leak.

## FIRST TIME RESIN CASTING | 4



3. Next, I used Aleene's Quick Dry Tacky Glue to attach the masters to the base of the box. To (try and) ensure that no rubber would seep underneath the masters, I ran a bead of glue around the entire perimeter of each part to, I hoped, form a nice seal/barrier. I wasn't too concerned about messing up the nice masters, since the Aleene's would just soak off with water. Make sure your box is absolutely level so your mold will come out level as well.

**VIEW READER  
COMMENTS**

*click here*







4. After letting the glue cure, it was time to mix and pour the rubber using the two-part material from the Micro-Mark resin casting starter set. Pour some of Part A in one cup and an equal amount of Part B in another cup.



5. Then mix the two cups of material together in a third, clear cup. Be sure to scrape out all the material from each cup.



6. Then mix the two parts by *slowly and gently* stirring them together. The clear cup helps you see how thoroughly you're mixing, and the gentle stirring helps prevent bubbles from forming.



7. When the materials are thoroughly mixed together, you're ready to pour. Well, almost. Set the cup down and tap on the sides for a minute or so to encourage any bubbles to surface so they'll pop. This material has a 10-minute working time from mix to pour, so you have some time for this step.





8. Pouring the rubber is both the most fun – it’s cool to see it coming out of the cup and into the mold box – but also the most scary, since you’re covering up, in this case, over \$40 worth of parts with liquid rubber. Start in one corner.



9. Work your way around with the pour.



10. Pour throughout the mold box, covering everything with *hopefully* enough material – at least 1/8” above the tallest part of the master. I had extra cups waiting in case I had to mix up more rubber quickly. To reduce bubbles, pour from high up so you have a thin, steady stream.



11. Use your stirrer to scrape out all the material – might as well use it all!





12. The final step, as with the rubber in the cup, is to tap on either side of the mold box to encourage the bubbles to surface and pop. Tapping releases the bubbles, and blowing across the surface helps them pop faster.



13. Here's what you end up with when you're done – a nice, smooth swath of rubber.

After waiting at least four hours for the rubber to cure (actually, I left it overnight), it was time to break the foamcore box away from the rubber mold.

**?** Did you know ...

**MRH registered members**  
**SAVE 10%**  
 ... on the MRH Store & on TrainMasters TV?  
 Click to get 10% off coupon code  
 (Must be a registered member to access)



14. The box broke away fairly easily, and I was able to peel the mold away. Not too bad – but I still got some seepage of rubber underneath the masters, despite running a bead of glue around the perimeter of each part. Next time, I'll make sure that the glue seeps out just a little around the edges – that should seal things nicely.





15. But that's next time. For now, I had some trimming to do. After trying a sharp X-Acto blade, I came up with the perfect solution – sprue nippers! As you can see above, they're straight and flush-cutting. Just what I needed to go around and trim off the extra rubber "flash."



16. Compare this photo with the "before" shot above, and I think you'll agree that the nippers worked great.

Next step was to mix and pour the resin. Thankfully, the process is similar to mixing and pouring the rubber.

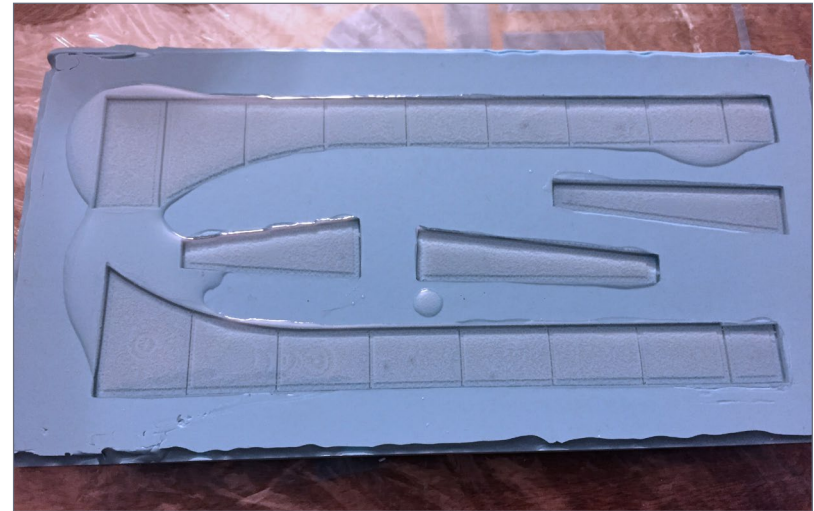

17. As before, I mixed equal parts of A and B together in a clear cup, then slowly poured the resin into the mold, doing my best to avoid bubbles. And – important (as I discovered later) – be sure to "overfill" the mold slightly. This is where making sure your foamcore box and mold are perfectly level pays off. And be sure you've put down some plastic to protect your workbench and catch any resin overflow.

**VIEW READER  
COMMENTS**

*[click here](#)*





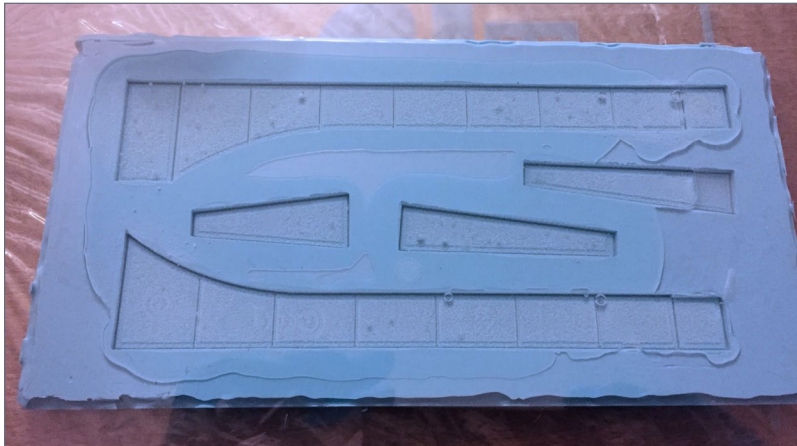

18. After over-filling the mold with resin, cover it with acetate or sheet styrene to keep the backs of the castings flat. As you can see, a few bubbles formed. I'm not sure yet how to avoid that, but decided they didn't matter since they'd be on the back of the castings.



First bridge girder casting.



19. Lastly, weigh it all down to compress and flatten the resin. The instructions on the resin say it takes about 15-20 minutes to cure (you know it's cured when it turns from clear to white), but to be certain the casting was as hard as possible, I left it overnight.

Another enjoyable – albeit anxiety-inducing – part of this process is removing the casting from the mold.

**VIEW READER COMMENTS**

*click here*





20. Once cured, remove the weight, peel off the acetate, peel the rubber mold off of the casting, and you should end up with something like this.



21. Unfortunately, there must have been some bubbling along a few of the girder edges. You can see above what look like "chips" that broke off. Nope – that's how the casting came out. This should be a relatively simple matter of filling them in with either putty or strip styrene, but I might not even bother, since these castings will be painted black and put under a bridge next to the backdrop.

Please tell your  
buddies about **MRH!**

**VIEW READER  
COMMENTS**

*click here*







22. Speaking of bubbles... My main mistake with this second set of castings was *not* overfilling the mold with the resin pour. As a result, a lot of air – and thus, bubbles – got trapped under the acetate. Then – *big mistake* – I tried to fix things by lifting the acetate and smoothing the bubbles out. That just made things worse and created more bubbles. It would have been better just to place the acetate, leave it alone, and see what I ended up with, come what may. Remember: *Always overfill the mold.*



23. Fortunately, the castings ended up OK. Yes, there are some voids, but they're either on the back where they won't be seen, or actually in the casting, where they *really* won't be seen – especially after painting.

**VIEW READER  
COMMENTS**

*click here*







24. Since I plan to use the masters for the front course of my bridge, I needed to remove them from the foamcore box. While it took a bit more effort than I expected, a soak in water eventually allowed me to carefully peel them off. And there wasn't even any residue! Certainly no damage to the masters, but I'll be sure to wash all the pieces thoroughly before painting them.

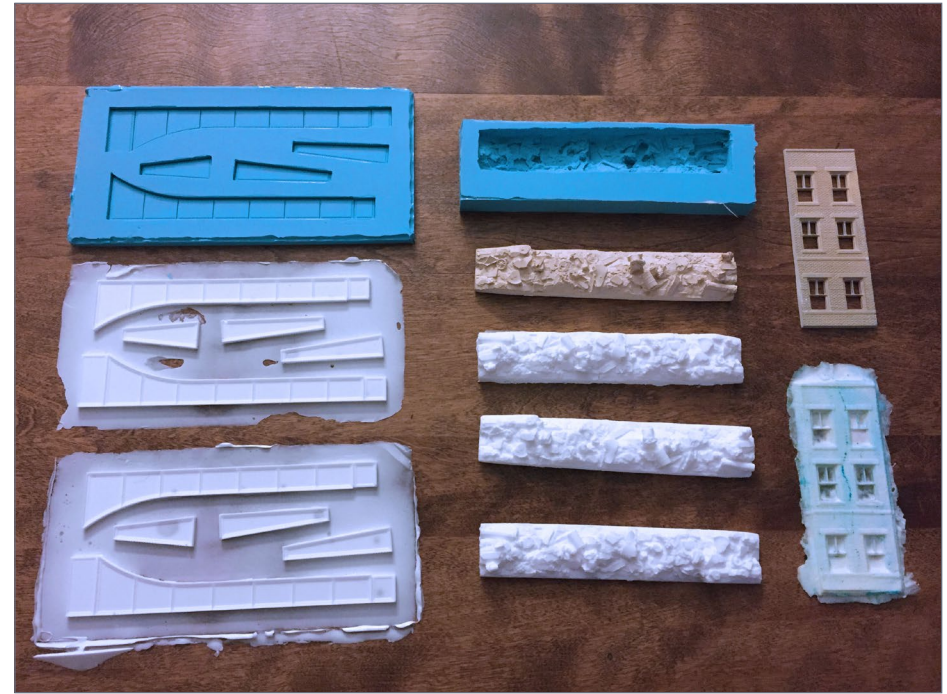

25. And that's it! I'm really glad I tried resin casting. It's not as difficult as I'd feared, at least not for duplicating flat-backed parts like walls, gondola loads, or even bridge girders (seen from one side). So I hope you'll give it a try and add this useful skill to your modeling arsenal. ☑

**VIEW READER  
COMMENTS**

*click here*



## LIST OF MATERIALS

- Micro-Mark Resin Casting Starter Set ([www.micromark.com/RESIN-CAST-STARTER-SET](http://www.micromark.com/RESIN-CAST-STARTER-SET))
- Clear plastic cups and rubber gloves
- Master part to be duplicated (preferably flat-backed)
- Foamcore board and hot glue
- Aleene's Quick Dry Tacky Glue ([www.aleenes.com/aleenes-quick-dry-tacky-glue](http://www.aleenes.com/aleenes-quick-dry-tacky-glue))
- Large sheet of acetate or styrene
- Sprue nippers
- X-Acto knife with fresh blades
- Weight ■

**When talking to hobby vendors, please remember to mention MRH.**

**VIEW READER COMMENTS**

*click here*



## CHRIS ADAMS



Chris Adams has been into model railroading, off and on, for almost 35 years after having “borrowed” the train set his kid brother received one Christmas after he got bored with it later that day.

Chris is primarily into the historical research side of the hobby, using his layout to create a “time machine” back to the New Haven Railroad of the late 1940s. When he’s not in the basement, he enjoys bike racing, reading, and maintaining a website dedicated to railroading in the lower Connecticut river valley at [www.thevalleylocal.net](http://www.thevalleylocal.net).

He also volunteers as a photo archivist for the New Haven Railroad Historical and Technical Association (NHRHTA), works full-time as a legal counsel for the Connecticut General Assembly, and occasionally as a steam locomotive fireman and student engineer at the Valley Railroad in Essex, CT.

Chris lives with his wife Debby in Old Saybrook, CT, within ear shot of the steam trains on the Valley Line. ■



**RATE THIS ARTICLE**



**THE FINE SCALE  
MODEL EXPO  
2018**

November 1st - 3rd,\* 2018  
Albany, New York

\*The vendor show opens at noon on Friday! at the Hilton Hotel



THE ONLY SHOW DEDICATED  
TO THE ART OF SCALE MODEL  
STRUCTURE BUILDING

**\$1000 CASH PRIZE  
MODEL CONTEST**

CLINICS & WORKSHOPS

AWARDS DINNER

DIORAMA DISPLAYS

LAYOUT TOURS

FINE SCALE MODEL VENDORS

**REGISTER TODAY!**

**THE FINE SCALE  
MODEL EXPO  
2018**

**@ The Hilton  
ALBANY, NY  
NOV 1-3\***

\*VENDOR SHOW NOV 2-3

**Participate in the Expo Model Contests  
and have a chance to win cash!**



**\$1000 CASH  
GRAND PRIZE  
FOR BEST OF SHOW**

SPONSORED BY THE  
SUNCOAST CENTER FOR  
FINE SCALE MODELING



**OCTOBER  
NEWS** column



Model Railroad Hobbyist | October 2018 | #104



**RATE THIS ARTICLE**

**RICHARD BALE** and  
**JEFF SHULTZ** report the latest hobby industry news

## Lionel Trains

The 118-year-old toy train company based in Concord, NC, reports that it is negotiating with ATI Model Products Inc. to acquire the tooling and manufacturing rights for the Model Power and Mantua product lines. Lionel said the acquisition will accelerate its expansion in the HO segment of model railroading and add complementary products and accessories to other portions of its business. Lionel has traditionally focused on the toy segment of the hobby rather than the prototypically accurate category of adult model railroading ...

## Trout Creek Engineering

Trout Creek Engineering reports that after struggling for an extended period of time trying to maintain a web site with an unreliable service, a completely new site has been built with

▶ **THE LATEST MODEL RAILROAD PRODUCTS, NEWS & EVENTS**



a different manager. The new site includes a detailed listing of Trout Creek, Classic Miniatures, BK Turnouts, and associated supplies. The new site is [troutcreekeng.co](http://troutcreekeng.co).

## NEW PRODUCTS FOR ALL SCALES

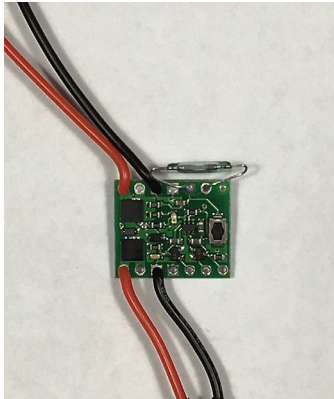

**Dead Rail Installs** is selling an on/off switch actuated by a magnetic reed. The device will control any electronic circuit and can be installed inside a locomotive, tender, or car. It can also be installed under scenery or inside a structure. The switch is turned on or off by waving a magnet near the hidden device. The unit is .6 x .6-inches square, by .7-inches high. For more information visit [deadrailinstalls.com](http://deadrailinstalls.com).

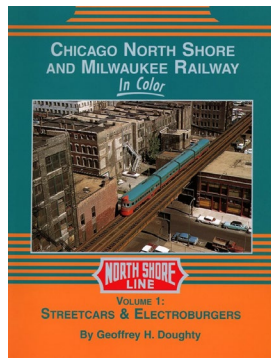

explores the North Shore interurban system including some rare color advertisements. Additional digital reprints include *Trackside Around Buffalo 1953-1976 with Ray Richards, Reg*

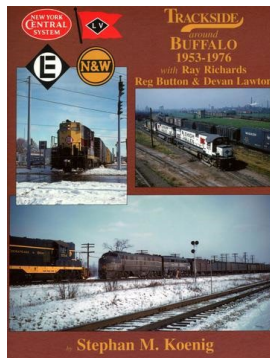

**Morning Sun Books** is selling a digital reprint of *Chicago North Shore and Milwaukee Railway, In Color Volume 1: Streetcars & Electroburgers*. Author Geoffrey Doughty

*Button and Devan Lawton*. For additional information contact a dealer or visit [morningsunbooks.com](http://morningsunbooks.com).

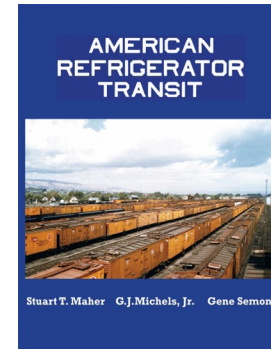

**Signature Press** has released *American Refrigerator Transit*, by Stuart T. Maher, G.J. Michels, Jr., and Gene Semon. This extensively researched new book covers the ART that transported produce from Texas and the southern Midwest to the nation's markets from the 1880s until the 1960s. The history of the company, its operations, and the fleet of cars behind it are the focus of this book. The

8.5 x 11-inch, 250-page hardbound book presents more than 400 photos that include the general appearance and lettering of a wide variety of ART cars. For additional information contact a dealer or visit [signaturepress.com](http://signaturepress.com).

**SoundTraxx** has released two new Tsunami2 DCC sound decoders, the Steam-2 steam and the EMD-2 diesel.

The Steam-2 decoder includes an additional 28 steam whistles to bring the total offered to 90, as well as 12 bells, 10 exhaust chuffs, 10 air pumps, and 8 dynamos. SoundTraxx states that this allows up to 2.2 billion sound combinations from the decoder.

The EMD-2 includes eight new EMD prime mover options - 657 12-cyl no-transition, 567C 16-cyl non-turbo, 645E 12-cyl non-turbo, 645E 12-cyl turbo, 645F 16-cyl turbo, 645E 20-cyl turbo, 701G 12-cyl, and 710G 16-cyl. All are new sound samples, not duplicates of any of the same type on the original Tsunami2 diesel decoder. For more information or to purchase, see your dealer or [soundtraxx.com](http://soundtraxx.com).







**Woodland Scenics** has introduced several new landscaping products called The Field System. The

new components include Static Grass in four colors and four lengths, Field Grass, and Briar Patch to help achieve realistic thickets, weeds, textures, and shadows. The range of colors and textures provides the material to model any season or grassy landscape. For additional information contact a dealer or visit [woodlandscenics.com](http://woodlandscenics.com).

## O SCALE PRODUCT NEWS



**3rd Rail Division of Sunset Models** has a limited number of Southern Pacific class S-12 0-6-0 switch engines available. Among the features of the all-brass handcrafted O

scale model is a fully detailed backhead. The control system is compatible with Legacy, DCS, and TMCC. For additional information visit [3rdrail.com](http://3rdrail.com).

**Crow River Products** sells a kit for this vintage lathe. The O scale model is composed of 23 pewter castings. The model shown is driven by an overhead belt system (not included). CRP is



developing a kit to convert the drive to a dummy electric motor. This is the first in a series of machine tools CRP plans to introduce. For additional information visit [crowriver-products.com](http://crowriver-products.com).



At the National Narrow Gauge Convention held in Minnesota last month, **Crystal River Products** announced plans to release a kit this fall for a D&RGW coal shed. The O scale model will be a laser-cut version of a model designed several years ago by Tom Fitzgerald, the original owner of Crystal River Products. The structure is typical of sheds found near

stations and section houses to store coal for railroad buildings and caboose stoves. Although new designs are on the horizon, the new owner plans to re-issue all of the original kits before delving into new products. For additional information visit [crystalriverproducts.com](http://crystalriverproducts.com).



**Downtown Deco** is selling an assortment of O scale boxes, trash cans, crates, and junk piles. The detailed items are sold in packs of 60. Labels for the crates are included along with suggestions for painting and weathering. To order visit [downtowndeco.com](http://downtowndeco.com).

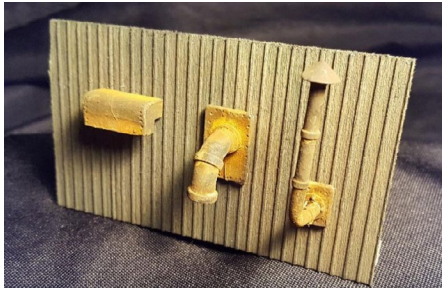

New O scale detail castings from **Rusty Rails** include a variety of vents for industrial buildings and a set of luggage. The luggage group includes two suitcases and a trunk. The cast resin items are supplied unpainted. For additional information visit [rustyrail.com](http://rustyrail.com).

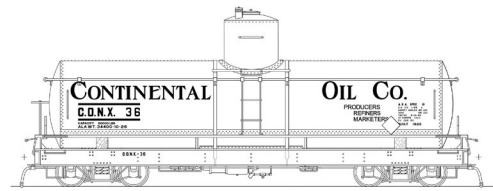

in 1926 for Continental Oil Co. Distinctive features of the narrow gauge cars include tall domes and a heavy outboard steel frame. The models are offered in five carefully researched lettering schemes: 1926, 1930 (above), 1935 (below), 1940, and Mexican National Railway.

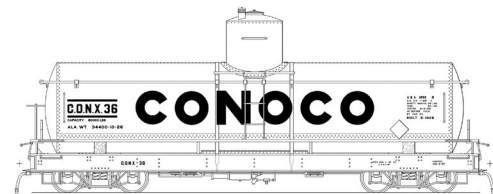

The model is made up of injection molded plastic parts including plastic arch bar trucks fitted with metal wheelsets. Orders are being accepted until the planned production run is filled. A specific release date has not been

**San Juan Model Company** is booking reservations for a production run of On3 tank cars based on a group of 20 prototypes built

The model is made up of injection molded plastic parts including plastic arch bar trucks fitted with metal wheelsets. Orders are being accepted until the planned

established but a lead time of one year is likely. For information visit [sanjuanmodelco.com](http://sanjuanmodelco.com).

## HO SCALE PRODUCT NEWS

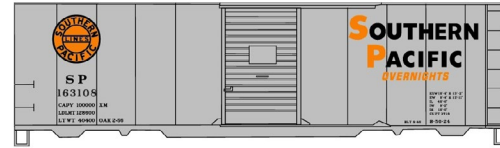

Heading the **Accurail** list of new HO scale car kits coming this month is a three-car set of 40-foot AAR boxcars decorated for Southern Pacific Overnight Service. SP launched the service in the 1930s and used several different paint schemes over the years to promote the service. The silver scheme on Accurail's new kit dates from the late 1950s.

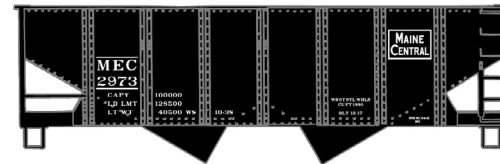

Accurail is selling this Maine Central twin-bay hopper in a three-car set of kits with different road numbers. Single cars are also available.



This Nashville Chattanooga & St. Louis 36-foot Fowler wood boxcar is available as an HO scale kit from Accurail. The model follows a prototype built in 1923 and rebuilt in 1940.

Accurail has released an HO scale kit for this 36-foot Philadelphia & Reading boxcar. It is based on a prototype





American Car & Foundry built in its Berwick, PA plant in 1913. The car features double-sheathed wood sides, wood ends,

and a straight steel underframe.

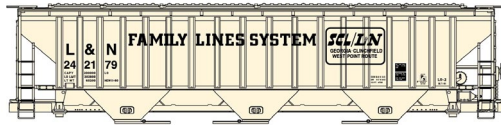

Pullman-Standard built the prototype of this 4750 cu. ft. triple-bay covered hopper for L&N Family

Lines in 1980.

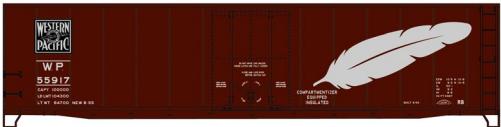

The prototype of Accurail's HO scale Western Pacific 50-foot insulated steel plug-door boxcar was built in the mid-1950s. The then state-of-the-art RB car had a capacity of 4327 cu. ft.



Accurail's HO scale version of this CB&Q 50-foot steel boxcar, also from the mid-1950s, is equipped

with Superior sliding doors.



Completing Accurail's recent list of new kits is this Soo Line 40-foot wood stock car. The HO scale model is based on a single-deck car built in 1921. All

Accurail kits include appropriate trucks and Accumate knuckle couplers. For additional information contact a dealer or visit [accurail.com](http://accurail.com).



**Athearn** has announced that three versions of a newly tooled

SD60E will be ready for release next July. The Genesis series HO scale model represents a group of SD60 diesels rebuilt in 2010 with mechanical upgrades and a unique new cab. In addition to its safety features, the replacement cab is readily identified by the flat nose with a center door, and a protruding housing above the windshield for the number boards and headlight. Athearn will offer the NS SD60E in three road numbers with each version having a slight variation in the fuel tank and type of antenna. A DC model will be available as well as an on-board sound version with a SoundTraxx Tsunami2 with a 1-inch speaker.



Also scheduled for release next July is a new production run of EMD SD39

diesel locomotives. The Ready-to-Roll series HO scale model will be available decorated for Soo Line Railroad, Lake States (Soo Line Lake States Transportation Division), and Illinois Terminal.

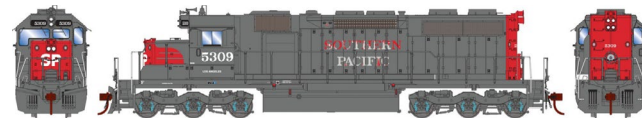

SD39s decorated in Athearn's Primed For Grime weathered

paint will be available for N&W, Southern Pacific, BNSF, Great Northern, and Santa Fe. The HO scale model will be available without sound and with Soundtraxx Econami Sound.



Rolling stock scheduled for release by

Athearn next July includes this 50-foot outside post insulated

boxcar. It is based on a prototype introduced by North American Car Corporation in the 1960s. Models decorated for Quaker Oats, Johnson Wax, and Canadian Pacific will have Superior plug doors.

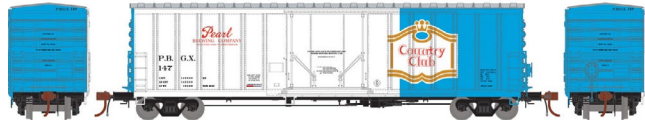

Cars decorated for Dakota, Minnesota & Eastern; Pearl

Brewing, and Chicago & North Western will have Pullman-Standard plug doors. The HO scale models will be fitted with metal grab irons, and 70-ton trucks with 33-inch turned metal wheelsets.



Athearn intermodal equipment due for release next July includes

this 53-foot reefer trailer. The HO scale model will have rubber tires and separately applied mud flaps. Fuel tanks and the location of a spare tire rack will vary depending on the practice of the prototype carrier being modeled. In addition to the Navajo Intermodal trailer shown, carrier names will include Conley, Western Distributing, KLLM, and England. The release will include an unlettered owner/operator version.



Athearn is preparing eight versions of this

Ford C stake bed truck for release next July. Decorated trucks will be available for REA, Builders Emporium, and Wickes Lumber. Five additional color combinations, without specific names, will be included in the release. Features of the ready-to-run model include clear window glazing, rubber tires, and molded cab interior.



**Roundhouse** brand models coming from Athearn in July include this Eastern-style steel

caboose with a centered cupola. The HO scale model will ride on Athearn's all-new Barber-Bettendorf swing motion caboose trucks with machined metal wheelsets.



Road names will be Boston & Maine, Penn Central, Pennsylvania, Chessie System (two

schemes), and Western Maryland. For additional information on Athearn and Roundhouse products contact a dealer or visit [athearn.com](http://athearn.com).



**Bowser** is selling HO scale models of General Electric U25B

locomotives in several road names. Phase IV versions of the Executive Line models are available decorated for New York Central, P&LE, Pennsylvania, Great Northern, and Milwaukee Road. Also available is Erie Lackawanna as repainted with a gray roof in the 1970s.



Phase II versions are available for PRR, Southern Pacific, and Union

Pacific. Notable details include windshield wipers, individual grab irons, coupler lift bars, operating headlight, and knuckle couplers. All units come with a new gearbox and AAR B trucks with a 9-foot 4-inch wheelbase. The HO scale models are available in a choice





of basic DC with a 21-pin plug for an aftermarket decoder or with factory-equipped DCC with a LokSound Select decoder. For additional information contact a dealer or visit [bowser-trains.com](http://bowser-trains.com).



**Broadway Limited** is offering an 11-car train set of the California Zephyr. Like the prototype, the BLI HO scale version of the famous train is made up of cars from the three railroads that jointly operated the

famous train from Chicago to San Francisco: Chicago, Burlington & Quincy; Denver & Rio Grande Western, and Western Pacific. BLI is also selling the cars individually.



The cars include a Vista Dome car (above) and a 10-6 sleeper decorated for each of the three roads, a baggage car and a 16-section sleeper for

D&RGW and CB&Q, a 6-5 sleeper and a Vista Dome dormitory-lounge car for WP and D&RGW, and a diner and Vista Dome 1-3 sleeper lounge observation car for WP and CB&Q.



In addition to the California Zephyr cars, a dome coach, dome observation, baggage car, and a 48-seat diner (above) are available for

the Wabash Railroad's Blue Bird that offered first class service between Chicago and St. Louis in the 1950s. BLI's HO scale models are molded plastic with a nickel finish. Features include detailed interior, tinted windows, operating sprung diaphragms, and numerous individually applied details such as grab irons. All cars, except the baggage car, have interior lighting. A minimum

22-inch radius is recommended. For additional information contact a dealer or visit [broadway-limited.com](http://broadway-limited.com).



**Downtown Deco** is selling an assortment of HO scale boxes, trash cans, crates, and junk piles. The detailed items are sold in packs of 60. Labels for the crates are included along with suggestions for painting and weathering. To order visit [downtowndeco.com](http://downtowndeco.com).

After several weeks of heavy negotiations, **ExactRail** received confirmation that their HO scale GSI bulkhead flat cars have been released for shipment to the US. The models were completed and ready for shipment from China when word came in late July that the factory had suddenly been shut down.



ExactRail is selling Johnstown America AutoFlood II coal hoppers in eight road names including the BNSF scheme shown above. Additional road

names for the HO scale model are CSXT, NRLX, CEFX, MAXX, and a special UCEX red, white and blue military veteran scheme.



The Evolution series model is a faithful reproduction of the lightweight aluminum cars Johnstown America introduced in the 1980s to replace aging 100-ton heavy steel cars. The

release was produced from corrected tooling that resulted in a more

accurate end cage including a U-channel reinforcement on the underside of the slope sheet. The ready-to-run model comes with Kadee No. 58 knuckle couplers and ASF 100-ton Ride Control trucks with 36-inch machined metal wheelsets. For more information visit [exactrail.com](http://exactrail.com).



**InterMountain Railway** is accepting reservations through the end of October for another production run of HO scale Southern Pacific cab forward locomotives. The schedule calls for four new road numbers for class AC-8, AC-10, AC-11 and AC-12 cab forwards. The four classes, all built by Baldwin Locomotive Works between 1939 and 1944, were virtually identical in appearance. The visual difference will be in the decorating scheme on the face of the locomotive and the lettering on the tender. Beginning prior to WWI *Southern Pacific Lines* was applied to the center of the tender (above), which all cab forwards received when new.



SP steam locomotives built or shopped after 1946 were lettered with a larger font on the tender and the word *Lines* was omitted. A DC model will be available as well as a DCC version with

an ESU LokSound Select sound decoder. For additional information contact a dealer or visit [intermountain-railway.com](http://intermountain-railway.com).

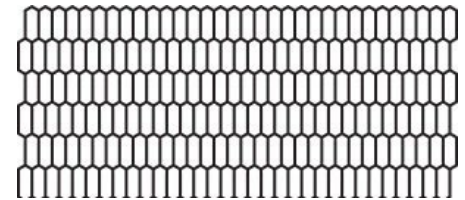
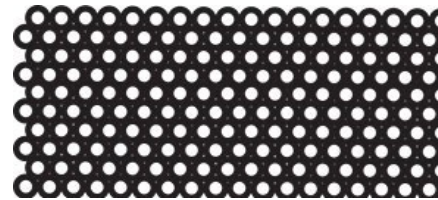
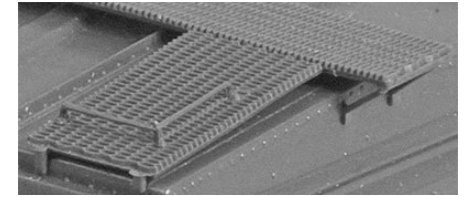
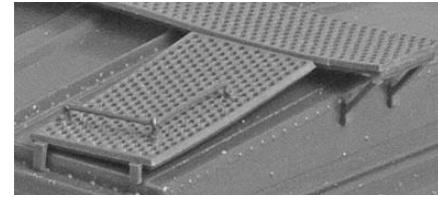

**Kadee** has introduced finely detailed plastic running boards that accurately represent metal prototypes. Above left is a punched metal running board and latitudinal as introduced by the Morton Manufacturing Co. in the late 1930s. On the right is an expanded metal running board and latitudinal developed by the U.S. Gypsum Co. The items will be available pre-colored in oxide red, boxcar red, black, and galvanized. Metal running boards and latitudinals were required on all new cars built after 1945. As of 1966 running boards were no longer required on new cars. A 1974 ARA directive required the removal all running boards on house cars. Both of these new freight car detail items will be welcomed by period modelers.



Pullman-Standard in 1953.

Kadee has scheduled a December release for two similar 40-foot PS-1 boxcars. Kadee's HO scale model replicates this Central of Georgia car that was built by





This Delaware & Hudson boxcar was built by Pullman-Standard in 1956. Both cars had 8-foot Youngstown sliding doors. Kadee's HO scale models

feature Kadee knuckle couplers and two-piece self-centering trucks. For additional information contact a dealer or visit [kadee.com](http://kadee.com).



**KatoUSA** is selling Gundersen MAXI-IV 3-unit articulated well-cars that can handle double-stack containers. Road names are BNSF (Swoosh), Pacer Stacktrain, TTX (original logo), TTX (New logo), and AOK. To ensure stability with

or without containers, the HO scale car is injection molded using a compound steel and plastic material.



Like the prototype, the three-unit articulated model has two different sized wheels. The end trucks have 33-inch wheels while the two middle trucks, which carry more weight, have 38-inch wheels.

Kato's 53-foot containers are available in two-packs decorated for BNSF, EMP, NACS, Swift, and Canadian National. Each container has a magnet and a metal plate to



hold it securely to the bottom of the well car or to the top of the lower container. For additional information contact a dealer or visit [katousa.com](http://katousa.com).



**Owl Mountain Models** is offering an HO scale kit for

Harriman class F-50-10 and F-50-12 flat cars. The craftsman-style kit includes brass detail parts, Kadee couplers, and special weights. Options include K or AB brakes, and ABS molded T-section or U-section trucks with metal wheelsets. A helpful video showing how to assemble the kit is available free at [www.youtube.com/watch?v=QWYlZEmp\\_ZE&index=42&list=PLnxQpj82XbtPqNr30P1g9cbqOTNBaIhUn](http://www.youtube.com/watch?v=QWYlZEmp_ZE&index=42&list=PLnxQpj82XbtPqNr30P1g9cbqOTNBaIhUn). The injection-molded model is based on a widely used Southern Pacific prototype built from 1916 to 1928. Many of the cars continued in MOW service until the late 1970s. White decals are available for Southern Pacific, Pacific Electric, Northwestern Pacific, Texas & New Orleans, and Galveston, Harrisburg & San Antonio. Black decals are available for SP MOW. For additional information visit [owlmtmodels.com](http://owlmtmodels.com).



**Oxford Diecast** has released two new 1:87 scale models of classic American vehicles. The ready to use models include a 1961 Cadillac DeVille Sedan



This 1965 Chevrolet Stepside Pickup is one of Oxford's recent releases.

For additional information contact an Oxford dealer or visit [walthers.com](http://walthers.com).



**Rusty Rails** is selling resin castings for this little garage with the front half of a 1940 Ford sticking out. The HO kit includes everything in the photo except the base and tree. The castings are unpainted. For additional information visit [rustyrail.com](http://rustyrail.com).

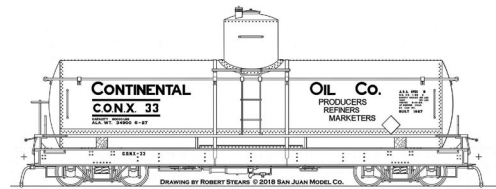

**San Juan Model Company** is booking reservations for a production run of HOn3 tank cars based on a group of 20 prototypes built for Continental Oil Co. in 1926.

Distinctive features of the narrow gauge cars include tall domes and a heavy outboard steel frame. The models are being offered in five authentic lettering schemes: 1926 (above), 1930, 1935, 1940 (below), and decorated for Mexican National Railway.

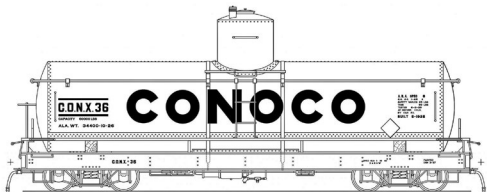

The HOn3 model is made up of injection molded plastic parts, including plastic arch bar trucks fitted with metal wheelsets. Orders are being accepted until the

planned production run is filled. A specific release date has not

been established but a lead time of one year is likely. For additional information visit [sanjuanmodelco.com](http://sanjuanmodelco.com).

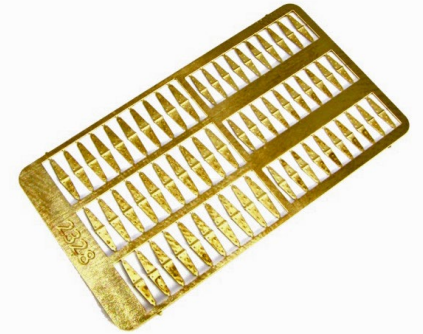

**Showcase Miniatures** has HO scale etched brass T and Strap Hinges. Each fret has 60 hinges. O scale hinges are also available.



Showcase Miniatures sells three different styles of HO scale trash cans: lid off, lid ajar, and lid on. The lid off is a separate piece and can be placed anywhere. The

unpainted cast metal cans are sold in packages of nine.



Also new from Showcase Miniatures is Huntley Iron Works, an HO scale craftsman-style kit featuring laser-cut components with peel and stick windows and cast pewter details. The instructions include weathering suggestions by Jason Jensen who designed and created the pilot model. The finished structure has a footprint of approximately 6 x 6-inches. For additional information

visit [showcaseminatures.net](http://showcaseminatures.net).





**Walthers** has scheduled a late November release for a new production run of Pullman-Standard 40-foot PS-1 boxcars. The HO scale

Mainline series model represents the early production of the PS-1. Spotting features include proprietary P-S ends without indentations in the top section and a bowtie roof with flat panels opposite the corner latitudinals.

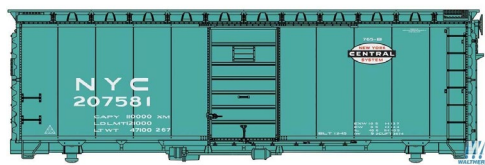

Additional details on Walthers ready-to-run model include a see-through Apex steel running board, 6-foot

seven-panel Superior doors, and 33-inch machined metal wheelsets. Road names will be Minneapolis, Northfield & Southern; Chicago Great Western, Milwaukee Road, New Haven, Rutland, and New York Central.



Walthers has announced plans to release a new group of HO scale 20-foot smooth side overseas containers in late January.

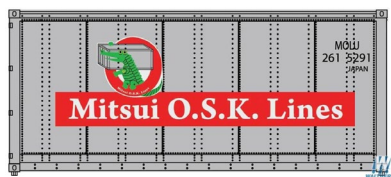

Carrier names will be American President Lines, Compass Container Company, Canadian National, CP Ships, NYK Lines, Manchester Liners, Mitsui

OSK Lines, and Y. S. Line. For additional information contact a dealer or visit [walthers.com](http://walthers.com).



**Yarmouth Model Works** plans to release several new resin freight car kits at the Chicagoland Railroad Prototype Modelers Conference to be held this month in Lisle, IL. In honor of the 25th anni-

versary of the event, formerly known as the Naperville RPM, one of the kits will be an HO scale model that replicates one of just ten 40-foot boxcars American Car & Foundry built for the Illinois Terminal Railroad Company shortly after WWII. ITC purchased the cars to replace several that had been wrecked.

Features of the 1:87 model include an ACF proprietary roof, ACF 3/4 ends, and several etched details including ladders and an Apex Tri-Lok metal running board. The cast body replicates the 12-welded panels of the prototype including the “oil canning” effect resulting from the heat of the welding process. Completing the model are Kato ASF A-3 trucks and custom decals prepared by Black Cat Publishing. The kit will not be available on-line until after the Chicagoland RPM Conference. For additional information visit [yarmouthmodelworks.com](http://yarmouthmodelworks.com).

## N SCALE PRODUCT NEWS



N scale rolling stock scheduled for release by **Athearn** next July

includes this 50-foot insulated boxcar with outside posts and plug doors. It is based on a prototype introduced by North American Car Corporation in the 1960s. Three numbers each will be available for

Dakota, Minnesota & Eastern; Quaker Oats, Johnson Wax, Canadian Pacific, Pearl Brewing, and Chicago & North Western.

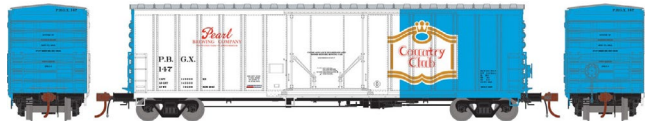

Features include etched metal stirrup steps, and 70-ton trucks with

machined 33-inch metal wheelsets. For additional information contact a dealer or visit [athearn.com](http://athearn.com).



**InterMountain Railway** is accepting reservations through the end of October for another production run of N scale Southern Pacific cab forward locomotives. The schedule calls for four new road numbers for class AC-8, AC-10, AC-11 and AC-12 cab forwards. The four classes, all built by Baldwin Locomotive Works between 1939 and 1944, were virtually identical in appearance. The visual difference will be in the decorating scheme on the face of the locomotive and the lettering on the tender. Beginning prior to WWI *Southern Pacific Lines* was applied to the center of the tender (above), which all cab forwards received when new.



SP steam locomotives built or shopped

after 1946 were lettered with a larger font on the tender and the word Lines was omitted. A DC model will be available as well

as a DCC version with an ESU LokSound Select sound decoder. For additional information contact a dealer or visit [intermountain-railway.com](http://intermountain-railway.com).



**KatoUSA's** N scale version of the Amtrak ACS-64 electric locomotive is now available with factory installed DCC. Road numbers include the signature David L. Gunn No. 600. Amtrak purchased the prototype ACS-64s to replace the

aging AEM-7 and HHP-8 electrics on the Keystone and Northeast Corridors.

KatoUSA's N scale SDP40F locomotives will also be available with factory installed DCC. DCC installed locomotives include Amtrak Phase II paint in two road numbers and ATSF with three road numbers. For additional information contact a dealer or visit [katousa.com](http://katousa.com).



**Micro-Trains** has announced the first car in a new series of 36-foot truss rod wood reefers. The series will feature reefers owned by

the H. J. Heinz Co. The first release in the series promotes Heinz Prepared Mustard.



Also new from Micro-Trains is this 70-foot Southern Pacific Husky-Stack well-car. The N scale model is based on a prototype built for

SP by Gunderson in 1990.







This ready-to-run Denver & Rio Grande Western Road steel caboose has been released to dealers by Micro-Trains. D&RGW built the full size 36-foot car in its

Burnham Car Shops in Denver, CO. Like the prototype, the N scale model rides on Bettendorf swing motion trucks.

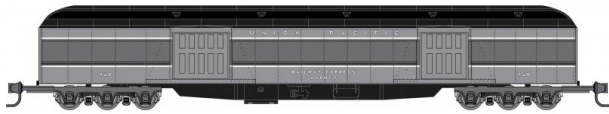

The latest N scale passenger car from Micro-Trains is a 70-foot Union Pacific

heavyweight baggage car. For additional information contact a dealer or visit [micro-trains.com](http://micro-trains.com).



**Showcase Miniatures** is selling a craftsman-style kit for an N scale structure titled Val-U Fuels & Oils. Features include pivoting windows, cast metal oil drums, meter base, roof vents, and trash cans. The step-by-step instructions include recommendations for painting and weathering. The assembled model

has a footprint of 2.75 x 3.25-inches. Figures shown are not included. For additional information visit [www.showcaseminatures.net](http://www.showcaseminatures.net).

## NEW DECALS, SIGNS AND FINISHING PRODUCTS

**Archer Transfers** has decals with raised surface details for EMD locomotive latches. The sheet consists of 45 resin latches



cast on Microscale clear decal film. They are applied like regular waterslide decals. The latches are available in O, S, and HO scales. For additional information visit [archertransfers.com](http://archertransfers.com).



**Microscale Industries** has water slide decals for contemporary graffiti. They can be used on freight cars, roadside walls, buildings, and fences. The decals are currently available in N and HO scale. For additional information contact a dealer or visit [microscale.com](http://microscale.com).

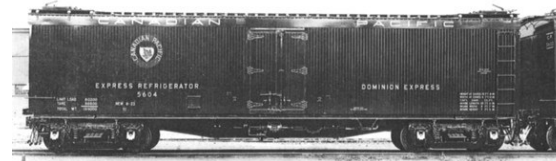

**Black Cat Decals** has Dulux gold decals for Canadian Pacific wood reefers with end ice bunkers numbered

5500-5749. This series of CPR cars was painted Tuscan red. For additional information visit [blackcatdecals.com](http://blackcatdecals.com).

**Mask Island Decals** sells lettering sets for several types of HO scale intermodal equipment including this C&EI Dorsey

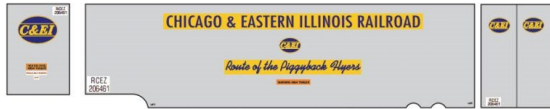

drop frame piggyback trailer with a *Route of the Piggyback Flyers* slogan.



Mask Island's decal set for Rock Island Intermodal Service trailer has enough material to letter three trailers.



decorate two 40-foot trailers.



The decal set for this Rock Island *Route Rock* will

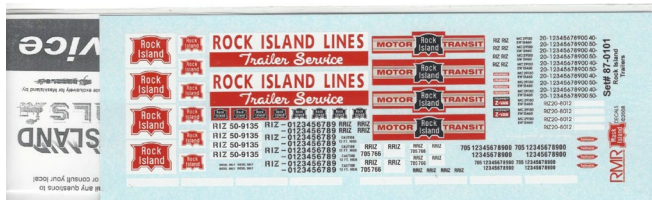

Rock Island Lines *Trailer Service* and two styles of Rock Island *Motor Transit* heralds

are included in this Mask Island decal set. For additional information visit [maskislanddecals.com](http://maskislanddecals.com).

## SEND US YOUR PRODUCT ANNOUNCEMENTS

If you are a hobby manufacturer with a product announcement, just [click here](#) and submit your announcement to us. Our web site and free magazine reach continues to grow, so get on board this new media train! ■

### DISCLAIMER .....

The opinions expressed in this column are those of the writer and do not necessarily reflect the opinion of *Model Railroad Hobbyist* or its sponsors. Every effort is made to provide our readers with accurate and responsible news and information, however, neither *Model Railroad Hobbyist* or the writer of this column can be held responsible for any inaccuracies or typographical errors that may inadvertently appear in this column.

**Use our custom Google search on the MRH website to find topics of interest**

Click to find out more

## DOWNLOAD ISSUE



DOWNLOAD PORTRAIT



DOWNLOAD LANDSCAPE





## ! BRIEFLY NOTED AT PRESS TIME ...

**KatoUSA** will re-issue its N scale Santa Fe Super Chief in 8-car and 4-car sets early next year. Together they will provide a complete 12-car name train. EMD F7 locomotives in Warbonnet paint with factory-installed DCC will also be available. As an alternative, ESU LokSound will be available as a special order. For HO modelers KatoUSA has added a Chicago Metra car to its pending re-release of Pullman Bi-Level commuter cars ...

**Mask Island Decals** has new water-slide lettering sets for Ashley Drew & Northern Railroad 40-foot boxcars, Norfolk Southern open hoppers (designed for the new Arrowhead committee hopper), Missouri Pacific ART rebuilds, and Southern Railway 50-foot P-S boxcars with Evans air pak. Info at [maskislanddecals.com](http://maskislanddecals.com) ...

**Morning Sun** has released *Conrail Power in Color, Volume 3* by Stephen M. Timko. The new hardcover volume looks at first- and second-generation SD, RSD, Alco Century, and six-axle GE units ...

**Rapido Trains** has posted a video showing its pre-production sample of the Royal Hudson. Note that the HO scale steam locomotive has no trouble pulling a 10-car passenger train. To view the video go to [www.youtube.com/watch?v=alkOqQ1ngAM](http://www.youtube.com/watch?v=alkOqQ1ngAM) ...



## The Amherst Railway Society Railroad Hobby Show

Our 2019 Show will be

# January 26 & 27, 2019

Save the dates!

Click  
to learn  
more ...



# SELECTED EVENTS



Model Railroad Hobbyist | October 2018 | #104



## OCTOBER 2018

*(Many events charge a fee. Check individual info website for details.)*

**CALIFORNIA, BELLFLOWER**, October 6, Los Angeles Area Prototype Modelers Meet, Encounter Christian Church, 10012 Ramona Street. Info at [laapm.org](http://laapm.org).

**CALIFORNIA, OCEANSIDE**, October 13, Swap Meet, sponsored by North County Model Railroad Society, Heritage Village Park, 230 Peyri Drive. Info at [ncmrs.org](http://ncmrs.org).

**CALIFORNIA, SAN LUIS OBISPO**, October 5-7, Central Coast Railroad Festival, Sands Inn & Suites, 1930 Monterey Street. Info at [ccrrf.com](http://ccrrf.com).

**CALIFORNIA, SAN PEDRO**, October 20-21, Open House & Swap Meet, Belmont Shore Railroad Club, 3601 South Gaffey Street. Info at [belmontshorerr.com](http://belmontshorerr.com).

**CANADA, OTTAWA**, October 20, 2nd Annual Capital Region Model Railway Self-Guided Tour, Registration at 9 am, St. Anthony's Banquet Hall, 523 St. Anthony St. Info at [www.capitaltrains.ca](http://www.capitaltrains.ca).

**COLORADO, COLORADO SPRINGS**, October 13-14, TECO-Train Expo Colorado, Chapel Hills Mall Event Center, 1710 Briargate Blvd. Info at [tecoshow.org](http://tecoshow.org).

**FLORIDA, PLANT CITY**, October 11-13, NMRA Sunshine Region 2018 Convention at Trinkle Center. HQ at Holiday Inn Express, 2102 North Park Road. Info at [sunshineregion.org](http://sunshineregion.org).

## SELECTED EVENTS | 2

**ILLINOIS, LISLE**, October 18-20, Chicagoland Railroad Prototype Modelers Conference, Sheraton Hotel and Conference Center, 3000 Warrenville Road. Info at [rpmconference.com](http://rpmconference.com).

**ILLINOIS, MORTON**, October 6, Central Illinois Train Xchange Swap Meet, Blessed Sacrament Church, 1020 South First Avenue. Request info from Roger Kujawa at [citrainx@gmail.com](mailto:citrainx@gmail.com).

**MASSACHUSETTS, BOXBOROUGH**, October 13-4, 54th Annual "Railfair 2018," Boxborough Regency Hotel, 242 Adams Place. Info at [www.nvrra.com](http://www.nvrra.com).

**MARYLAND, ROCKVILLE**, October 4-7, NMRA Mid-Eastern Region Convention, Hilton Hotel, 1750 Rockville Pike. Info at [Potomac-nmra.org/MER2018/Main/index.html](http://Potomac-nmra.org/MER2018/Main/index.html).

**MICHIGAN, WYOMING (Grand Rapids)**, October 13, Fall Train Show, sponsored by Grand River Valley Railroad Club, Home School Building, 5625 Burlingame Avenue SW. Info at [grvrrc.org](http://grvrrc.org).

**MISSOURI, TRUESDALE**, October 6-7, Railroad Days Train Show & Swap Meet, sponsored by Central Missouri Railroad Association, at Rebecca Boone Elementary Gymnasium, 836 South Street. Info at [www.cmrraclub.com/trainshow.html](http://www.cmrraclub.com/trainshow.html).

**NEW JERSEY, MERCHANTVILLE**, October 27, All Scale Swap Meet, sponsored by Cherry Valley Model Railroad Club, at Grace Episcopal Church, 5 Maple Avenue. Direct inquiries to Ernest Kraus at 856-468-8537.

**NORTH CAROLINA, WINSTON-SALEM**, October 10-20, Carolinas School of Railway Prototype Modeling, 1450 Fairchild Road. Info at [sissonstony.wixsite.com/rpm-carolina](http://sissonstony.wixsite.com/rpm-carolina).

**PENNSYLVANIA, EASTON**, October 7, 42nd Annual Lehigh Valley Regional Train Show & Expo, co-sponsored by Railroad Historians of the Lehigh Valley and Lehigh Valley Chapter of the National Railroad Historical Society, Charles Chrin Community Center, 4100 Green Pond Road. Info at [www.lehighlines.org/uploads/9/1/4/5/91456028/2018\\_regional\\_train\\_show\\_and\\_expo\\_flyer.pdf](http://www.lehighlines.org/uploads/9/1/4/5/91456028/2018_regional_train_show_and_expo_flyer.pdf).





## SELECTED EVENTS | 3

**VIRGINIA, RICHMOND**, October 19-21, James River Rails Operations Weekend, Layouts in the Richmond/South-Central Virginia area. Info at [www.jamesriverrails.org](http://www.jamesriverrails.org).

**VIRGINIA, VIRGINIA BEACH**, October 13-14, Train Show & Sale, sponsored by NMRA Mid-East Region, Tidewater Division, Virginia Beach Convention Center, 1000 19th Street. Info at [nmra-mer-tidewater.org](http://nmra-mer-tidewater.org).

**WASHINGTON, CHEHALIS**, October 13-14, Train Show & Swap Meet, sponsored by Lewis County Model Railroad Club at SWW Fair Grounds, 2555 North National Avenue. Request info at [tedstrains@lewiscounty.com](mailto:tedstrains@lewiscounty.com).

**WASHINGTON, PORT ANGELES**, October 13-14, 19th Annual Train Show & Swap Meet, sponsored by North Olympic Peninsula Railroaders, Clallam County Fair Grounds, 1608 West 16th Street. Request info from Steve Stripp at 360-582-1316.

### November 2018, by location

**CANADA, ONTARIO, FENWICK**, November 17-25, Open House at Greater Niagara Model Railroad Engineers, 1141 Maple Street (rear). Info at [www.gnmre.ca/contact.asp](http://www.gnmre.ca/contact.asp).

**MAINE, BREWER**, November 12, Train Show sponsored by Eastern Maine Model Railroad Club at Jeff's Catering, 15 Littlefield Way. Request info from Geoff Anthony at [dahak@road-runner.com](mailto:dahak@road-runner.com).

**MICHIGAN, ANN ARBOR**, November 25, Model Train Show sponsored by Rails On Wheels, at Washtenaw Farm Council Grounds, 5055 Ann Arbor Saline Road. Request info from Walt Trancygiere at [trancywj@gmail.com](mailto:trancywj@gmail.com).

**MICHIGAN, EAST LANSING**, November 11. Model Railroad Show & Sale, sponsored by Lansing Model Railroad Club, Michigan State University Pavilion, 4301 Farm Lane. Info at [lmrc.org/trainshow/index.shtml](http://lmrc.org/trainshow/index.shtml).

## SELECTED EVENTS | 4

**NEW YORK, ALBANY**, November 1-3, Fine Scale Model Expo 2018, Hilton Hotel, 40 Lodge Street. Info at [info@ModelRailroadEXPO.com](mailto:info@ModelRailroadEXPO.com).

**NEW YORK, BATAVIA**, November 11, Greater Batavia Fall Train Show, sponsored by Genesee Society of Model Engineers, at Genesee Community College, Richard C. Call Arena. Info at [gsme.org/home-1](http://gsme.org/home-1).

**PENNSYLVANIA, ALLENTOWN**, November 10-11, First Frost Train Meet, Allentown Fairgrounds, 1920 W. Chew Street. Info at [allentowntrainmeet.com](http://allentowntrainmeet.com).

**SOUTH CAROLINA, NORTH CHARLESTON**, November 17-18, Fall Train Show, Danny Jones Armory Complex, 5000 Lackawanna Blvd. Info at [camrc.club](http://camrc.club).

**TENNESSEE, MEMPHIS**, November 17, Train Show & Open House, sponsored by Memphis Area Model Railroaders, at 4445 Malone Road. Info [memphismodelrailroaders.com](http://memphismodelrailroaders.com).

**UTAH, ST. GEORGE**, November 9-12, Annual Layout Tour sponsored by Color Country Model Railroad Club. Info at See [www.colorcountrytrains.org](http://www.colorcountrytrains.org).

### Future 2018, by location

**MASSACHUSETTS, MARLBOROUGH**, December 1-2, New England Model Train Expo, hosted by NMRA HUB Division, Best Western Royal Plaza Trade Center, 181 Boston Post Road. Info at [hubdiv.org](http://hubdiv.org).

**NEW YORK, ALBANY**, December 2, Annual Great Train Extravaganza hosted by NMRA Hudson-Berkshire Division, Empire State Convention Center. Info at [gtealbany.com](http://gtealbany.com).

**OHIO, LIMA**, December 15, Train Town Show & Swap Meet, sponsored by NMRA NCR 3 Rivers Division, at Merchants Building at Allen County Fairgrounds, 2750 Harding Highway (St Rt 309). Request info from Chuck White at [railcarman@frontier.com](mailto:railcarman@frontier.com). ■



# DERAILMENTS



RATE THIS ARTICLE

Model Railroad Hobbyist | October 2018 | #104

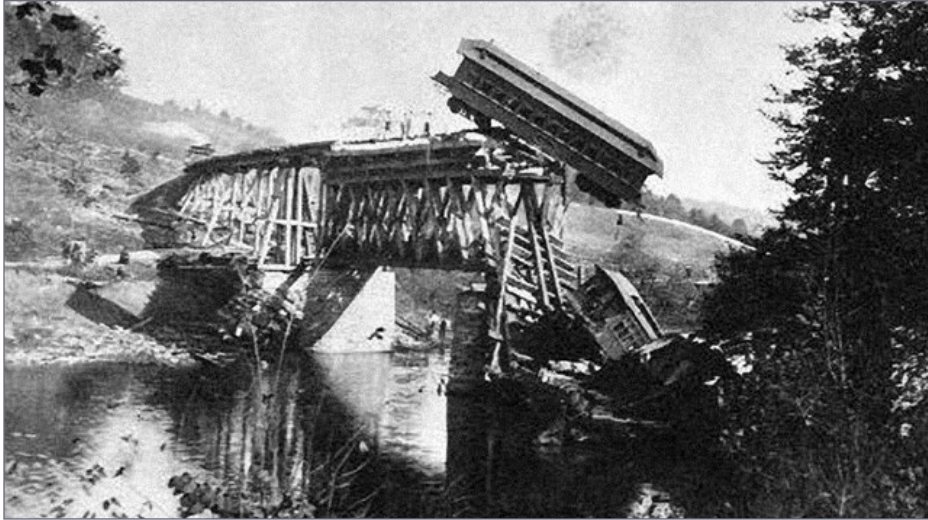

## Don't *anybody* move ...

If you were in this delicately balanced passenger car, you wouldn't dare breathe for fear you would alter the precarious equilibrium and topple seventy-some feet into the river and wreckage below!

We wonder if anyone was in that car *and* if they ever got them out without mishap. Talk about a bad day ... ■

**VIEW READER  
COMMENTS**

*click here*

► BIZARRE FACTS AND HUMOR (SUPPOSEDLY)

## CLICKABLE ADVERTISER INDEX

[Accu-Lites](#)  
[Altoona Model Works](#)  
[Amherst Railway Society](#)  
[Archer Fine Transfers](#)  
[Atlas Model Railroad Co.](#)  
[Athearn](#)  
[Bachmann](#)  
[Backdrop Junction](#)  
[Berrett Hill Trains](#)  
[Black Cat Publishing](#)  
[Blair Line](#)  
[Bowser](#)  
[Caboose](#)  
[Canyon Creek Scenics](#)  
[Coastmans Scenic Products](#)  
[Coffman Graphics](#)  
[Crow River Products](#)  
[Daniel Cortopassi Productions](#)  
[Digitrax \(2 page spread\)](#)  
[East Penn Traction Club](#)  
[El Dorado Software](#)  
[ESU LokSound](#)  
[Fast Tracks](#)  
[Fast Tracks \(Scale Lumber\)](#)  
[Fine Scale Miniatures](#)  
[Fine Scale Model Expo](#)  
[Great Decals](#)  
[HO Diesel Supply](#)  
[Iowa Scaled Engineering \(ISE\)](#)  
[ITLA Scale Models](#)  
[Kenpatterson.com](#)  
[Lights 4 Models](#)  
[Litchfield Station](#)  
[Logic Rail Technologies](#)  
[Main Street Heritage Models](#)  
[Masterpiece Modules](#)  
[Micro-Trains Line](#)  
[Mike & Scotty Live](#)  
[Model Railroad Control Systems](#)  
[Monashee Laser Engineering](#)  
[Mountain Subdivision Hobbies](#)  
[MRH Store \(1\)](#)  
[NCE \(2 page spread\)](#)  
[North American Railcar Co.](#)  
[Old West Scenery](#)  
[Pre-Size Model Specialities](#)  
[Precision Design Co.](#)  
[Pulsar Pro Decal FX](#)  
[Rapido \(1\)](#)  
[Rapido \(2\)](#)  
[Ring Engineering \(1\)](#)  
[Ring Engineering \(2\)](#)  
[Scale Trains](#)  
[Soundtraxx \(Blackstone\)](#)  
[Southern Digital](#)  
[Streamlined Backshop Services](#)  
[TAM Valley Depot](#)  
[TrainMasters TV \(1\)](#)  
[TrainMasters TV \(2\)](#)  
[TrainMasters TV \(3\)](#)  
[Traintek](#)  
[Walthers](#)  
[Westerfield Models](#)  
[Yankee Dabbler](#)  
[Yarmouth Model Works](#)

---

[Clickable "other" index](#)  
[Other - Contents](#)  
[Other - Cover](#)  
[Other - Derailments](#)  
[Other - MRH Marketplace](#)  
[Other - MRH Sponsors](#)





# REVERSE RUNNING

commentary



Model Railroad Hobbyist | October 2018 | #104

**JOE FUGATE: THINGS THAT GO  
BUMP IN THE NIGHT ...**



**I WOKE UP ONE NIGHT**  
and could not go back to sleep.

As I laid there in bed, I thought I heard a noise in the basement! I focused carefully and waited – there it was again.

Definitely something in the basement. But what?

I got up, just in my undershorts, and cautiously walked down the hall to the stairway, listening as I went.

It was muffled, but another definite “thump” from the basement. What could it be?

My layout is in the basement and my imagination started running wild. Did we have a prowler and

was he collecting up my trains to take off with them and make a killing on eBay?

I also had visions of leprechauns or gnomes secretly running my trains at night while I slept – *but that’s silly*, I thought to myself. I had been watching too many late night creature features!

I tip-toed down the stairs and there it was again – a muffled but definite *thump*. Somebody was in the basement for sure!

As I got to the bottom of the stairs and rounded the corner into the basement hall, I could see light under the train room door! Somebody – or worse some *thing* was in the train room!

My heart pounded as I crept up to the train room door.

I hoped I wasn’t being robbed blind, but I swallowed hard and thought to myself, “Okay, time to be brave – let’s catch them in the act!” I could feel the hair standing up on my arms and legs.

On the count of three, I whispered to myself. I took a deep breath.

“One ... two ... *three!*”

As I edged the door open, the room lights were clearly on and blazing away.

Suddenly, in a flash, he ran between my feet – the prowler!

I chased him down and caught him, the rascal! It was our house cat and he had green foam strewn all about his snout. Busted! He had clearly been up on the layout and romping around.

That’s when I remembered I had been working on the layout and left for a bit, closing the door. But I got distracted and never made it back to the layout, leaving the lights on – and locking an unwitting visitor into the layout room for the night.

It was back to bed, secure in the realization I had found the train room prowler and would survey the layout in the morning to assess the damage he had done. What a night!

▶ **STEPPING OUTSIDE THE BOX WITH A CONTRARY VIEW**





**COMING NEXT MONTH IN MRH ...**



Jim Lincoln models in Proto:48 ...

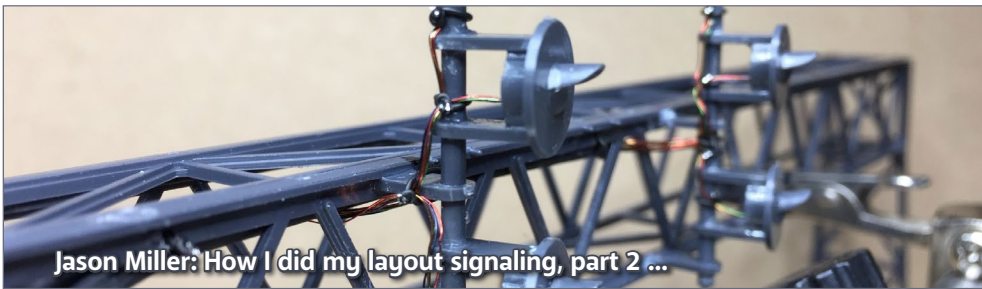

Jason Miller: How I did my layout signaling, part 2 ...

HAVING FUN WITH TRAINS  
NOVEMBER 2018 | FREE

**MRH**  
MODEL RAILROAD HOBBYIST

Also:  
- Questions, answers, and tips  
- Add LED lighting to Blue Box Locomotives  
- How I did my signals, part 2  
- New options for modeling bridges  
- The latest new product announcements ... all inside!

**Jim Lincoln**  
**Models in Proto:48**  
▶ **READ NOW**

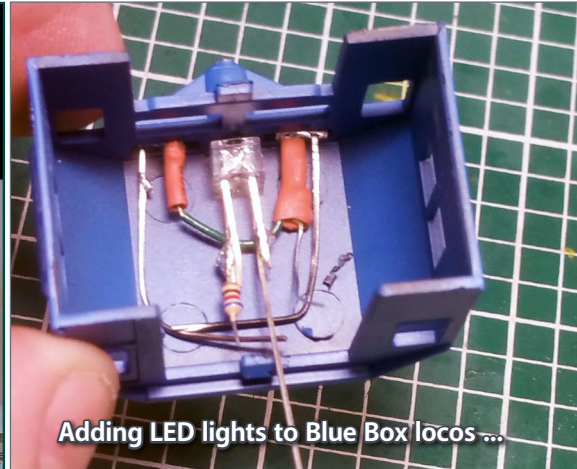

Adding LED lights to Blue Box locomotives ...

... coming in the  
November MRH

**COMING NEXT MONTH IN *Running Extra* ...**

... all the MRH articles and ads, *PLUS:*

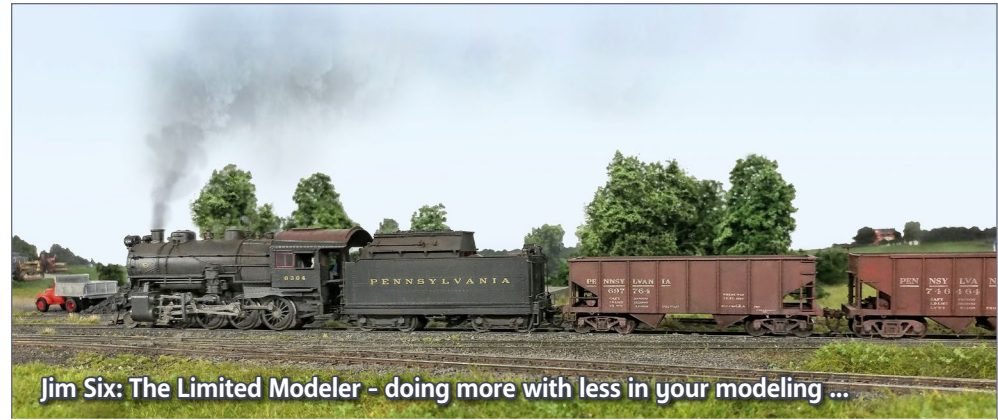

Jim Six: The Limited Modeler - doing more with less in your modeling ...



Building a herniated helix ...

November 2018 - \$1.99

**MRH** **RUNNING**  
EXTRA  
More modeling every month

Jim Lincoln  
**Models in Proto:48**  
▶ **READ NOW**

**Also these articles:**  
- New Jim Six column on doing more with less  
- Model a working coal tower  
- Building a herniated helix  
- Backdrop with a backlit sky  
- Logging and railbarge layout plan  
... and much more!



Model a working coal tower ...

... all this and much more!

**SUBSCRIBE: 1YR \$19.99**