

# Model Railroad Hobbyist magazine™

Price:  
Forever Free

STANDARD  
Edition

The model-trains-video.com mediaZine

Mar/Apr 2010

## George Sellios' Franklin & South Manchester

The man and his newly updated model railroad

Bringing new life to your model scenes

IN DEPTH: Modeling rooftop details

Build a static grass applicator

And much more ... *inside!*



**Front Cover:** A mixed freight and passenger local pulls out of Franklin on George Sellios' Franklin & South Manchester. George has been busy making changes and updates to his well-known layout, and the MRH staff got a chance to visit with George and learn what's behind these changes.

ISSN 2152-7423

#### Editorial Staff

Joe D. Fugate, Publisher  
Charlie Comstock, Layouts and media editor

#### Columnists

Ryan Andersen, New media  
Richard Bale, News and events  
John Drye, N scale  
Lew Matt, Narrow gauge and shortlines  
Marty McGuirk, Prototype modeling  
Tim Warris, Trackwork

#### Special Correspondents

Jim Duncan, Layouts and operations  
Byron Henderson, Layouts and track planning

#### Production

Patty Fugate, pasteup and layout  
Joe Brugger, copy editing  
Mike Dodd, copy editing

#### Technical Assistant

Jeff Shultz

#### Advertising Account Manager

Les Halmos



Click to learn more about this sponsor



Click to learn more about this sponsor



Click to learn more about this sponsor

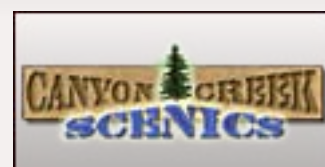

Click to learn more about this sponsor



Click to learn more about this sponsor



Click to learn more about this sponsor



Click to learn more about this sponsor



Click to learn more about this sponsor



Click to learn more about this sponsor

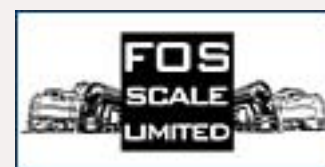

Click to learn more about this sponsor



Click to learn more about this sponsor

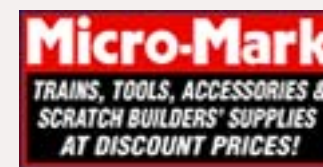

Click to learn more about this sponsor



Click to learn more about this sponsor



Click to learn more about this sponsor



Click to learn more about this sponsor



Click to learn more about this sponsor



Click to learn more about this sponsor



Click to learn more about this sponsor



Click to learn more about this sponsor



Click to learn more about this sponsor



Click to learn more about this sponsor



Click to learn more about this sponsor



Click to learn more about this sponsor



Click to learn more about this sponsor



Click to learn more about this sponsor

**Sponsoring Advertisers - Visit them and say: "Thanks for bringing me MRH completely free."**

**Your logo could be on this page, putting your web site just one click away from tens of thousands\* of readers!**

Our click tracking indicates sponsoring advertisers get up to *double* the clicks ...



**[Click here](#) to learn how to become a *sponsoring advertiser*.**

\* Our oldest issue, released in January 2009, has now had 45,000 downloads – and continues to get hundreds of new downloads per month even now. Sponsoring advertisers who've been with us since issue 1 are still getting clicks from all our back issues, from their logo on our web site, *as well from as our current issue*. A sponsoring ad with MRH is truly an *investment* in growing your business.

# VICTORY



for prototype  
**MODELERS**

**NEW!** 200' BRASS Truss Bridges

WATCH THE VIDEO



[www.YouTube.com/blmamodels](http://www.YouTube.com/blmamodels)



**HO scale \$445**

- #5002 - Silver
- #5003 - Black

**N scale \$325**

- #2002 - Silver
- #2003 - Black

**Pre-Order Now!**

- 100% Assembled
- ALL-BRASS Construction
- 200 Scale Feet Long
- Painted (Silver or Black)
- Extremely Fine Detail
- Double-Stack Clearance



**NEW!**

## US&S Searchlight Signals

WATCH THE VIDEO



**HO SCALE NOW AVAILABLE!**

Dual Head, Platform Ladder, w/Tall Base

HO #4050	\$44.95
N #1050	\$TBA

Single Head, Platform Ladder, w/Tall Base

HO #4051	\$34.95
N #1051	\$TBA



**NEW!**

## Modern Signals

WATCH THE VIDEO



Modern Single Head Block Signal

HO #4037 \$34.95



**NOW AVAILABLE!**

ORDER NOW THROUGH YOUR FAVORITE DEALER!

# BLMAmodels.com



562-712-7085 sales@blmamodels.com

**THE**

# **BULLFROG**

## **MANUAL THURNOUT CONTROL**



-  **Inexpensive**
-  **Integrated Control Rod Mount**
-  **Automatic Power Routing**
-  **Full Selection Of Supporting Products**



**\$9**

**Ready  
To Install**

**You Assemble It**



**\$6**



Order online now at:  
[www.fast-tracks.net/bullfrog](http://www.fast-tracks.net/bullfrog)

# We're here to give you a hand



**Click to learn how ...**

**Do more. Spend less.**



**[model-trains-video.com](http://model-trains-video.com)**

**It's a  
real crime  
when  
you miss  
out on a  
limited  
run  
model ...**



***to the  
rescue!***



**Click here to learn  
how to prevent  
this crime!**

# Main Features

# Table of contents

# Columns



**33** **Leaving Las Vegas**  
UP Track plan in a 9 x 11 room  
*by Bob Sprague*



**80** **Bringing your layout alive**  
Adding "movement" to static scenes  
*by Bob Grech*



**39** **Hopper Loads**  
Scenery Scene: one evening project  
*by Charlie Comstock*

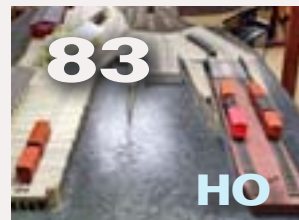

**83** **Craig Bisgeier's Housatonic**  
Modeling 1890s railroading  
*by Charlie Comstock and Les Halmos*



**41** **Franklin & South Manchester**  
George Sellios' latest layout changes  
*by Charlie Comstock and Joe Fugate*

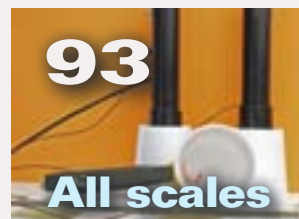

**93** **Static Grass Applicators**  
3 different ways to build your own  
*by Kevin Rowbotham*

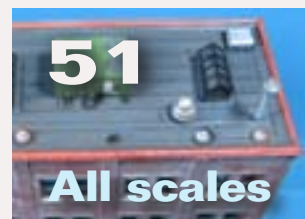

**51** **Rooftop details**  
In depth how-to for your structures  
*by Tom Wilson*



**122** **Product FIRST LOOK**  
New cars from ExactRail and Tangent  
*by Jeff Shultz*

**20** **March Model Railroading News**  
MRH News and Events  
*by Richard Bale*

**126** **Tunnel liners**  
Up the Creek  
*by Charlie Comstock*

**134** **3 x 6, the new 4 x 8?**  
Comme-N-tary  
*by John Drye*

**139** **Photography - new or old media?**  
New Media Modeler  
*by Ryan Andersen*

**142** **Time Out! Bigger isn't always Better ...**  
Reverse Running  
*by Joe Fugate*

**15** **Bonus downloads this issue!**

# Other Features

**11** **Turn a small project into a large project, part 2**  
Publisher's Editorial *by Joe Fugate*

**14** **MRH Staff Notes**  
Building issues on a bimonthly schedule, and more ...

**30** **MRH Q - A - T**  
Questions, Answers and Tips

# NEW NOSEY.



# CLICK HERE.





# Digitrax UT4D Duplex Equipped Utility Throttles

## Select, Run and Dispatch

## Without Plugging In!

Shipping Now! The UT4D is the latest in the UT4 series of Digitrax Utility Throttles. Operators from around the world asked for a simple to use, affordable throttle with intuitive operation & rock solid design. Based on operator input, Digitrax created the UT4 throttles.

UT4D is Duplex Equipped to work with the UR92 Duplex Transceiver. It can also be used as a walk around throttle with UP5 or as InfraRed with any Digitrax InfraRed Receiver.

For UT4 & UT4R upgrade information visit [www.digitrax.com/ut4upgrades](http://www.digitrax.com/ut4upgrades)

Digitrax, Inc. 2443 Transmitter Road, Panama City, FL 32404  
Phone 850 872-9890 / Fax 850 872-9557 [www.digitrax.com](http://www.digitrax.com)

**UT4D \$135.00 msrp**



# TELL US WHAT YOU WANT. WE'LL HELP YOU FIND IT.

SPECIALISTS IN HO, O AND N SCALE HARD-TO-FIND ITEMS

BPL Brassworks' sophisticated Want List system "sends up a flare" when a new collection comes in with just what you're looking for, and we send you a "heads up." You won't miss out on the opportunity to add that sought-after item to your own collection. You know what to look for, and we provide crisp, detailed photos to give you confidence in the quality and value of our offerings.

FINE DOMESTIC AND IMPORTED BRASS MODELS FOR  
DISCRIMINATING COLLECTORS AND OPERATORS.

- All major importers and domestic manufacturers
- Newest manufacturer offerings
- Want List system for special requests and hard-to-find items
- One-to-one personal service
- More than 15 years of railroading study and experience
- A boss who's as passionate about brass and trains as you are
- Order confirmations, layaway and prepayment options available

*Make our web site your first stop for the newest offerings.*



2 6 2 - 3 7 5 - 1 1 0 7

CLICK FOR MORE INFO



## PUBLISHER'S EDITORIAL: Turn a small project into a large project, part 2

Musings from the MRH founder

### About the Publisher



**Joe Fugate** is the featured expert in many [Model-Trains-Video.com](http://Model-Trains-Video.com) videos, and he's also the founder and publisher of **Model Railroad Hobbyist Magazine**.

To learn more about Joe, [click here](#).



**As you read last issue, my staging turnout replacement project went really bad ...**

**N**ow that I had found the mystery short in staging – a stray metal wheel wedged between the closure rails of a turnout – I still had the problem of *no turnouts* on the west (Eugene) end of my staging yard.

I started this whole project because I wanted to replace the poorly performing commercial turnouts on my west staging ladder with spot-on-NMRA-spec jig-built turnouts<sup>1</sup>.

Even though I know better, my big mistake was not checking these turnouts for shorts before I installed them.

Out of frustration from making such a foolish oversight, I hastily stuck a putty knife under the turnouts I had just fastened down and ripped them up out of the caulk without much care.

<sup>1</sup> My “poor man’s” jig approach uses Central Valley turnout ties strips to get much-improved turnouts that are spot-on the NMRA RP dimensions for HO turnouts. I show how I build these turnouts on my [Siskiyou Line web site](#).



**Checking for shorts in my jig-built turnouts is the one vital step I missed in this project, so I made very sure to check the turnouts for shorts the second time around! I use a volt-ohm meter set on continuity - if there's a short, it emits a loud beep.**

I figured the turnouts were a total loss so I was not especially careful in pulling them up with the putty knife. They came up easy enough, but I expected to just start over and build new turnouts.

Imagine my surprise when I later examined these turnouts and saw they had survived the whole ordeal amazingly well. This is a real testimony to the ruggedness of turnouts built using these methods!

I'm now *even more certain* that building turnouts using PC ties to fasten the rails down is *the way to go!*

In the photo above, I'm checking my one curved turnout for shorts. As a result of this test, I found at least two different PC ties where I had failed to cut the proper gaps in the copper foil. I unsoldered the PC ties, cut the proper foil gaps, and resoldered the rails.

In effect, I had the *perfect storm* scenario in my staging. Not only were these turnouts full of shorts, but I had a mystery short on the other end of staging as well from a stray metal wheel!

To add insult to injury on this project, I also skipped a crucial step in making

changes to trackwork. I typically check the trackwork first by turning on the layout power and ensuring I have no shorts or wiring problems.

Then if I introduce a short while installing new trackwork, there's no question where it is.

But I didn't do that this time because I got cocky.

*Shame on me.*

I am happy to report, however, that I'm able to salvage *all* the turnouts I ripped up and will soon have the west end of staging in operation again.

As you can see from this nightmare scenario, even experienced modelers can make a mistake. For crying out loud, I've been in the hobby for 40 years - but did that protect me from doing something stupid?

Not in the least.

One of the things I have learned over the years is to not fear making mistakes. In fact, you should *welcome* mistakes.

While making mistakes is never fun, it's how we learn. One of the definitions of an expert is they've made more mistakes in a given craft than other people.

*Did you ever think of that?*

Do you want to become an expert modeler? Then go do some model railroading and make mistakes.

**“As you can see from this nightmare scenario, even experienced modelers can make a mistake. For crying out loud, I've been in the hobby for 40 years ...”**

When you do make mistakes on something (and you will make several if you've never done it much before), don't let it discourage you.

Just say to yourself, “One more step to becoming an expert!”

Hanging out on model railroading forums can be useful because you hear about other people's mistakes, so you don't have to make them yourself.

Learning really comes both from your own mistakes and from hearing about other's mistakes, so we can all hopefully avoid *that one* ourselves.

I like the Layout Design Special Interest Group's motto, “make only new mistakes”.

Too bad I wasn't paying closer attention to that motto on this project, aye?

# Have us add sound to your favorite loco!



# Model Railroad Hobbyist Hobby Marketplace

## MODEL RAILROAD TIPS

Have an article you just can't seem to get published? Submit it to [ModelRailroadTips.com](http://ModelRailroadTips.com) today!



Home to 100% free online and PDF articles. Upload an article online, and we'll take care of the PDF file for you.

## SHELFTRAX

If you are looking for a great way to display your N, HO and O trains, try grooved ShelfTrax.

Attaches to the wall without brackets.



Learn more at [www.shelftrax.com](http://www.shelftrax.com)

## LBH Custom Model Railroads

Layout Design and Construction Services

For more information visit our website:

[www.lbhmodelrailroads.com](http://www.lbhmodelrailroads.com)



Reach well over 25,000 modelers with your text-only ad on this page for as little as \$15 per issue.

[Learn the details here.](#)



**Berrett Hill Trains**  
Custom Layouts and Modules  
[www.berretthill.com](http://www.berretthill.com)

- Shop built sections delivered and set up. Move your layout whenever you want to.
- Built to any level of completion: bench-work, rails, wiring, or scenery.
- Design for dramatic scenery is our specialty.
- CAD design for precise track placement and grades.
- Wiring for AC, DC, or DCC. All sections mate with universal harness plugs.
- Serving the eastern US.

See us at the Great Scale Model Train Shows.



# Railflyer Model Prototypes

[www.railflyermodelprototypes.com](http://www.railflyermodelprototypes.com)

Arriving in 2010: "Prototype Correct" SD40-2's

Click for more ...

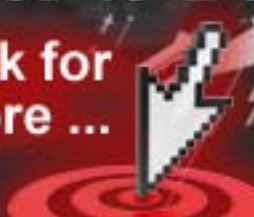

Accuracy, Integrity, Precision...

## Rayonier #2 -- A Willamette lives again

\$22.00 plus \$3 s/h

Click to learn more ...

[www.trainvideosandparts.com](http://www.trainvideosandparts.com)



**Rayonier #2 -- A Willamette lives again**  
At the Mt Rainier Scenic Railroad  
A Pictures & Words Production by Jeff Johnston © 2009



Proud supporters of "MODEL RAILROAD HOBBYIST"



**Timesaver Layouts**  
AUSTRALASIAN DISTRIBUTOR  
[www.timesaverlayouts.com](http://www.timesaverlayouts.com)  
timesaverlayouts1@bigpond.com

- \* Cost effective Turnout - Semaphore & Crossing control
- \* Frog and Lighting control at your fingertips
- \* Compatible with all DCC systems
- \* Useable on DC or DCC layouts
- \* **Dealer Applications WELCOME**



[www.anemodel.com](http://www.anemodel.com)  
**SmartSwitch**™



Click for more ...

# LISTEN UP!

SPONSORED BY:  
THE MODEL RAILROAD  
HOBBYIST MAGAZINE

# The Scotty Mason Show

THE FIRST INTERNET  
MODEL RAILROADING  
PODCAST

Get the Latest Model Railroading  
News, Tips, Reviews & Opinions  
From These Knuckleheads.

Scotty Mason

Jimmy Deignan

Dave Frary

Doug Foscale

Available here or on iTunes

[www.modelrailroadpodcast.com](http://www.modelrailroadpodcast.com)

## Notes from the MRH Staff

Building issues on a bimonthly schedule, have MRH tutor you, and more ...



As we move to our bimonthly production schedule, we're streamlining things so we can crank out issues 30 percent faster.

For one thing, we're focusing more on deadlines. That means if a particular column or article is ready by the deadline, then great, it goes in that issue. Otherwise, it's in the next issue.

In practical terms, that means each issue will probably be a little smaller than the quarterly issues. However, over the course of a year you'll get more total pages of content than you got when we were quarterly.

And more frequent issues means you'll generally get content 30% faster.

But if smaller issues are a problem for you, I suppose you could always ask for your money back ...

## MRH University?

Would you like the MRH staff to help you with your next modeling project?

We're entertaining this idea, and if having seasoned modelers teach you how to do some part of the hobby, then maybe we can help.

The idea is you would hire us to be your personal tutor for a certain project, and then we would work together via the internet, webcasts, even visits to your location to help you with your project. If that sounds like something you'd like to explore, then contact us and let's discuss it.

We can only offer this in a limited way since we do have constraints on our time (like producing a magazine).

It's first come, first serve.

## Bonus downloads

Make sure you check out the bonus downloads for this issue. The goodies include:

- Free Fast Clock Program (Adobe AIR, which runs on Macs and Linux as well as PCs).
- DVD quality video of most videos in this issue.
- You can also get access to the bonus goodies from previous issues through the [bonus download link](#).

Note that the bonus downloads are only good for the first 30 days after an issue release. We do the bonus downloads to encourage early downloading of each issue. If you wait too long to

download an issue, you'll miss out – so don't procrastinate!

## Write for us

Now that we're on a bimonthly schedule, we need more article submissions than ever.

It's also worth saying up front that acceptance is not guaranteed. We reject article submissions too. As the buyer, we are the customer in this transaction. As they say, the customer (us in this case) is always right.

The most common reason for rejecting a submission is poor photography. The second most common reason is

the article isn't a topic we want to cover in the manner the author has approached it.

If you want to increase your odds that we'll accept your article, first send us a query [via this link on our web site](#).

We will respond within a week or two and let you know if your idea is something we would be interested in. We'll often also give you some guidelines as to approach.

**Packaging up your article:** When you put your article together to submit to us, here's a checklist of things to do:

- Include your full name and email address in the article text. You

## Issue 6 Bonus Downloads!

Free for the first 30 days after issue release  
(After April 5, 2010, these extras will no longer be available)

- Free Fast Clock program
- DVD-quality versions of this issue's videos
- Special money-saving advertiser coupon codes



**Click here to access**

## Everything you need to know about model building in one great How-To resource...the Micro-Mark catalog!

More than 2,750 name-brand and hard-to-find tools, trains and supplies, plus tips, techniques and more...all designed to help you complete your hobby projects in less time with more satisfying, professional results!

# Micro-Mark®

Berkeley Heights, New Jersey 07922  
**1-800-225-1066**



**Free Catalog!**

Click [here](#) and enter code BA5

**1-800-225-1066**  
Shop On-Line: [www.micromark.com](http://www.micromark.com)



would be surprised how many submissions we get *without* this information!

- Include captions for all photos, diagrams, drawings, tables, and videos as a separate document.
- Include a version of your document that has the images and diagrams inline in the text if you like, but also give us a text-only version of your article.
- Write us a short bio about yourself and your hobby interests. Include a recent photo.

We prefer the Microsoft Word format for documents. For images, send us

2-3 megapixel jpgs at least 1800 x 1200 pixels.

If you don't have a copy of Microsoft Word or Office, you can [download a free copy of Open Office here](#). Open Office reads and writes Microsoft Office formatted files.

For drawings or diagrams, contact us and we'll give you some guidance how to produce them for publication with us.

### **Promoting MRH**

As we mentioned last issue, we're looking for volunteers to help promote MRH at various shows in 2010.

We're attending these shows in force ourselves:

- **Amherst Show (Springfield, MA) – January 30-31, 2010 ... [click here to see our video report from this show!](#)**
- **NMRA National Convention (Milwaukee, WI) – July 11-18, 2010**
- **National Narrow Gauge Convention (St. Louis, MO) – September 1-4, 2010**
- **Craftsman Structure Show (Mansfield, MA) – November 10-13, 2010**

If you'd like to help, first we're looking for **local volunteers** to help us at any of the above shows.

For any shows we're not attending, we're looking for some level of help promoting MRH. For example:

- Put flyers and CDs out on the free handouts table.
- Help staff a table. More on this below.
- Help us get flyers and CDs in the registrant bags (if the event has such things)

If you're willing to help staff a table, we'll pay for the table and pay the entry fee for you and any reliable volunteers you can get to help spell you at the table.

We'll give you an official MRH shirt to wear at the event (yours to keep),



- DCC Specialists
- Digitrax-NCE-LENZ-Soundtraxx
- TCS-QSI Solutions-RR CirKits

**We are an Authorized Walthers and Digitrax Dealer  
We offer 20% off the MSRP on ALL Walthers Catalog Items!**

**Watch our website for our monthly specials!**

**CLICK TO LEARN MORE: <http://www.acculites.com>**





we'll send you promotional materials, and provide guidelines on how to promote us.

Just click here if you're [interested in helping out at a show!](#)

## Apple iPad

By now most of you tech types have seen Apples announcement of their new iPad. It's a full color personal media reader that's very thin and portable, but it's a near 8x10 page size and a battery life of up to 10 hours. The price starts at \$499.

We've felt for a while that the personal media reader market is about to

explode with devices that make it very easy and convenient to read things like *Model Railroad Hobbyist* magazine in your easy chair, or at the layout when you're doing a project.

Amazon's had their Kindle for over a year now, but it's been more of a paperback novel size. Plus we find the Kindle's black and white screen better suited to reading fiction books.

Magazines need a larger full-color interface, and of course MRH also benefits from internet connectivity and the ability to play back video content.

The Apple iPad is the first device that finally has these capabilities all in a single lightweight "pad of paper" electronic device.

Rumor has it Google is also working on such a device, along with other firms you may not have heard of like Que.

We believe this is the next wave that's going to continue shaking up the paper publishing business and accelerate the widespread transformation to epublishing.

Newspapers and magazines have been feeling the pinch from the internet for some time now.

We'll be getting an iPad this April and demoing MRH at shows. The iPad memory will allow you to keep several decades of eZines at your fingertips! ■



## DCC Systems - DCC Decoders DCC + Sound Installations

Also offering quality  
model trains and model  
railroading accessories in  
HO & N Scale!



CLICK HERE  
TO VISIT OUR WEBSITE!

[DCCinstalled.com](http://DCCinstalled.com)

**Looking to unlock your layout control and take it to fantastic new levels?**



**Look no further than**

**CLICK TO LEARN MORE**



# RailroadKITS

## DANNEN FEEDS

Only \$9



MRR Television's Boz Collins says "These Little Kits Are Cool!"

### Railroad Kits Structures:

- Great Designs in HO Scale
- Laser Cut Basswood Walls
- Northeastern Scale Lumber™
- Tichy™ Doors and Windows
- Metal and/or Resin Detail Castings
- Online, Printable Instructions



Visit us at [www.RailroadKits.com](http://www.RailroadKits.com)

# MODEL TRAINS WEATHERED

.COM

## THE WORLD'S ONLY WEATHERER'S NETWORK FORUM

STOP BY TODAY AND INQUIRE ABOUT MEMBERSHIP



# Model Railroad Hobbyist newsletter™

March 2010

▶ **Reader Feedback**  
(click here)



*The Old Yardmaster*



## News and views from up and down the line...

**A**ccurail ([www accurail.com](http://www accurail.com)) has released a newly-tooled **HO scale** offset-side hopper car decorated for Pittsburgh & West Virginia. The car is painted black with white graphics.

Accurail has also released new decorating schemes on several additional freight cars including a SLSF/Frisco 41-foot steel gondola; a white Soo Line ACF center-flow covered-hopper with black, green and yellow graphics; a Western Pacific 40-foot steel boxcar with silver and black graphics; an Atlantic Coast Line 40-foot double-door steel boxcar and a Northern Pacific 50-foot double-door steel

boxcar with white, black and red graphics.

Also new this month is a Canadian National 89-foot partially-enclosed bi-level auto-rack car painted black with white graphics and silver panels.

**A**s we promised last month, here are more details on several **HO scale** ready-to-run freight cars coming from **Athearn** ([www.athearn.com](http://www.athearn.com)) this summer. The group includes 40-foot steel boxcars with Youngstown doors decorated for Pacific Great Eastern, Susquehanna, UP and Wabash; 50-foot steel boxcars with Youngstown doors for UP

(orange body, black lettering, red, white and blue shield), UP (yellow body with "We Can Handle It" slogan and a red, white and blue UP shield), MP, USEX/Canfor (with "From The Forests of Western Canada" slogan); an FMC-4700 covered-hopper decorated for CAGX/UP, Mid Iowa, Percivil and Val-U-High; and a cupola-style steel caboose decorated for D&RGW, T&P, Wabash, and USMC Camp Pendleton (in Desert Storm camouflage). All of the above items are tentatively scheduled to go to dealers in May.

Two **N scale** items are also due from Athearn in May including a bay-window caboose decorated for Southern Pacific, SSW/Cotton Belt, Norfolk Southern and CSX (Operation Redblock scheme with light blue body and hash-mark safety frame in yellow and dark blue). Also a PS2-2600 two-bay covered-hopper for CSX (patch), L&N-Family Lines, Detroit Toledo & Ironton, MKT/BKTY, Grand Trunk Western and Montana Rail Link.

Athearn has scheduled a June delivery for a series of **N scale** Ethanol tank cars decorated for NATX (in 7 different road numbers), UTLX (10 road numbers), and TILX (7 road numbers).

**B**achmann ([www.bachmanntrains.com](http://www.bachmanntrains.com)) has been showing preliminary samples of its **HO scale** new Peter Witt street cars at some of the recent winter shows. First up will be models of the Cleveland

and Toronto cars with the **O scale** versions expected in May.

**T**o avoid the possibility of future supply problems, **Blackstone** ([www.blackstonemodels.com](http://www.blackstonemodels.com)) is designing a different motor and gear-head arrangement for the next production run of **Hon3 scale** K-27 locomotives. That's welcome news to current Mudhen owners who have had difficulty finding replacement motors, since the new gear-head and motor can be used as a retrofit on locomotives from the original run. For additional details visit their website above.

**B**LMA Models ([www.blmamodels.com](http://www.blmamodels.com)) has released an ACF 89-foot class F89-J flat car in both **HO** and **N scale**. The initial run of the 40-year old prototype will be decorated in 1990s-era RTTX schemes with six different road numbers.

Built by American Car & Foundry from 1966 through 1968, the prototype cars were designed to carry three 28-foot trailers or two 45-foot trailers. We concur with MRH staff member Jeff Shultz who posted on his blog, "It's been good recently for HO scale flatcar and Intermodal modelers - with the Atlas, Athearn, BLMA, and Walther's piggyback flat cars, in addition to the various spine and well-cars. Intermodal modelers are going to enjoy an embarrassment of riches."

**A**mong the newest items from **ExactRail** ([www.exactrail.com](http://www.exactrail.com)) are two fully-assembled ready-to-



**FIGURE 1:** Atlas ([www.atlasrr.com](http://www.atlasrr.com)) is working on a series of wood billboard-style refers displaying a variety of beer brands including Old Heidelberg, Schlitz, Blatz Beer, Karlsbrau Beer and Schmidt's. A 36-foot truss-rod car will be used for the HO scale billboard refers while the N scale cars will be 40-foot in length. The billboard refers are due in August.

A look at the Atlas production schedule shows the new HO scale GP-39-2 Phase 2 diesel arriving in October. Priced at under \$100, the economical Trainman series locomotive features a five-pole skewed-armature motor with dual flywheels, locating dimples for mounting grab irons, Accumate couplers, an NMRA 8-pin plug for DCC and a 2,600 or 3,600 gallon fuel tank appropriate to the prototype road.

New decorating schemes for Atlas' N scale GP38-2 diesel include BNSF, CN-GTW, CSX, Delaware & Hudson, Durham Southern, Penn Central, Soo Line and Union Pacific. Several undecorated models will be in the release including units with and without dynamic brake housings, with a split radiator and no dynamic brakes, and with an extended-range dynamic brake housing. All of the GP38-2s should be ready by August.

In response to several inquiries regarding the National Steel coil car, Atlas announced last summer, we can report that, despite some minor delays, the HO scale project is very much alive. Although specific dates have not been released, test shots from the new tooling could be ready for review within the next few weeks.

roll cars including an N scale Thrall 3564 gondola and an HO scale PS-2CD covered hopper car. The 3564 gondola is painted and lettered for NOKL, TTX, SP, CP, CSXT and BNSF. Features of the PS-2CD include an etched-metal running board and Kadee #58 couplers. Roadnames on the initial run include Milwaukee Road, Chessie System (with Western Maryland reporting marks), Continental (with TLDX reporting marks) and Burlington Northern.

In response to the rapid sell-through of its HO scale ARMN R-70-2 refrigerator cars, InterMountain Railway is now taking reservations for another run of the refers with delivery expected late this summer. Meanwhile, the company is preparing tooling for an N scale version of the same car. For more details including reservation information visit [www.imrcmodels.com](http://www.imrcmodels.com).

New HO scale cars coming from Kadee Quality Products ([www.kadee.com](http://www.kadee.com))

in April include a Seaboard Air Line 40-foot boxcar #25645 with an 8-foot door and GTW 40-foot boxcar #516869 also with an 8-foot door. The 1957-built GTW car features a galvanized roof and will be decorated in factory-fresh red oxide paint.

Last year Kadee introduced a split-bolster truck with equalizing characteristics comparable to a fully-sprung truck. Following on that success, Kadee has designed four new HO scale trucks with split-bolsters. Two of the new models will be available with either rib-back or smooth-back wheel sets.

The new units are an Arch Bar truck with rib-back wheels (#561), a 50-ton A.S.F. A-3 Ride-Control truck (#562 with smooth-back wheels, #563 with rib-back wheels), and a 50-ton Bettendorf-type truck (#564 with smooth-back wheels, #565 with rib-back wheels). Also a new 70-ton Barber S2-B friction-bearing truck (#566 with smooth-back wheels only) which will be introduced on a soon-to-be announced 50-foot PS-1 boxcar.

M2FQ Publications ([www.maine2footquarterly.com](http://www.maine2footquarterly.com)) has a new 21-page electronic book

### Scale Color Key:

Z scale news

N scale news

HO scale news

S scale news

O scale news

G scale news



We try to make it really easy for you to leave us feedback. Please click the button below and tell us how we're doing: good, bad, or otherwise.

that features drawings and photos of WW&F Weeks Mill Tank. Some of the drawings by Elsworth Gray were previously published in Maine 2-Foot Quarterly. Priced at \$12, publisher Gary Kohler says buyers who order direct will receive any future updates, revisions or new photos at no additional cost. For more details contact Gary at the above web site.

**Moloco** has announced the availability of several new **HO scale** freight car parts including car cushioning and non-cushioned draft gear for sliding sills based on ACF, Evans/USRE, FGE, NACC, PCF and PS prototypes. For full details visit the company's web site at [www.molocotrains.com](http://www.molocotrains.com).

**Smoky Mountain Model Works** is developing an **HO scale** kit for a Southern Railway 6000 series 50-foot gondola with a tentative release date of mid-April.

The prototype cars were built in 1953 and saw revenue service into the 1980s and MOW service for an additional ten years.

The urethane kit will include a 1-piece body with a separate underframe, hidden brass weight, decals, miscellaneous detail parts, a pair of Kadee #58 couplers and appropriate trucks. Detailed step-by-step instruction will be supplied on a mini CD.

Orders are being taken now at [www.smokymountainmodelworks.com](http://www.smokymountainmodelworks.com).

**Rio Grande Models** ([www.riograndemodels.com](http://www.riograndemodels.com)) has an **HO n3** kit for a D&RGW series 4000 boxcar. The craftsman-style kit is composed of laser-cut body components, a plastic roof, white metal castings, Grandt Line detail parts, decals and Blackstone trucks. The kit can be ordered direct from the above web site at \$30 plus shipping.

*Continued on page 24 ...*



**FIGURE 2:** Atlas O ([www.atlaso.com](http://www.atlaso.com)) has scheduled a late summer arrival date for several new **O scale** cars including a 53-foot Evans double plug-door box car for Boston & Maine, British Columbia, Illinois Central (above left), Chicago & North Western, Wisconsin & Southern (American flag) and Illinois Terminal. Also an 11,000 gallon tank car for Hooker-Niagara Falls (above right), Cities Service, Lion Oil, Shamrock, Calor and Skelly Oil. An undecorated tank car will be included in the run.



**FIGURE 3:** Bowser ([www.bowser-trains.com](http://www.bowser-trains.com)) will release its Alco Century C-630M late this year decorated in the livery of several different Canadian lines. The initial run of the **HO scale** diesels will include Canadian Pacific and BC Rail, as shown above, as well as CN (red nose, black & white hash stripes), CP Rail (red-body), and BC Rail (gray over black). The diesels are from Bowser's upscale Executive Line and will be available for straight DC at \$170 or with Soundtraxx Tsunami Sound and two speakers at \$270.

Other features include Dofasco trucks with all-wheel pick-up, 8-pin NMRA plug (DCC-ready), working ditch lights, photo-etched radiator walkway and windshield wipers, brass MU hoses and air line, and an extra heavy frame. Selected features appropriate to individual roads include location of bell, fuel tanks and correct plows or pilots.

**FIGURE 3:** BTS ([www.btsrr.com](http://www.btsrr.com)) has both **HO** and **O scale** kits for this City Point Water Tank. See-through "water" is included in the kit which is composed of cardstock and laser-cut wood. The finished structure occupies a scale footprint of about 36 by 13-feet.





FIGURE 4: Broadway Limited ([www.broadway-limited.com](http://www.broadway-limited.com)) has released it's long-awaited HO scale EMD high-hood SD40-2 diesel. The 3,000 hp prototype was built by General Motors Electro-Motive Division between 1972 and 1986 – a 14-year production run for one of the best-selling locomotives of all time. The Paragon2 model is offered in several road schemes including CP (Flags paint scheme), NS (white sill), NS (black sill as shown above), NW, NW (with Norfolk & Western lettering) and SRR (tuxedo scheme).



FIGURE 5: Barlow's Smokehouse is the latest craftsman kit from Fos Scale Limited. The HO scale kit features numerous signs, a roof-top pig, laser-cut roof lettering, precut one-piece rafter strips, engraved pig sign, metal roofing, corrugated metal for walls, scribed siding, Tichy plastic windows and doors, laser-cut benches and metal detail parts. The two main structures are connected by an angled transition section, however, the buildings can be modeled separately if desired. For additional photos and ordering information visit [www.foslimited.com](http://www.foslimited.com).



FIGURE 6: Frenchman River Model Works ([www.frenchmanriver.com](http://www.frenchmanriver.com)) has introduced a 1:48 scale 45-foot Harbor Tug ideal for O scale industrial waterfront scenes or funky On3/ On30 harbors. The superstructure, wheelhouse, tire bumpers, running-lights, smokestack, life float, doors, bow fender and waterline hull are all cast in resin. The windows and searchlight lens are laser-cut. Lead-free pewter castings include a mast, searchlight, anchor, horn, davit and bitts. The completed model is 11.5-inches long.



FIGURE 7: Foothill Model Works has a new On30/On3 scale kit for an unusual coal gondola. Although free-lance in design, the new all-styrene model is representative of typical home-grown cars used on narrow gauge lines. Included in the kit are T-16 trucks with 24-inch wheel sets, brake beams and brake levers. Visit [www.foothillmodelworks.com](http://www.foothillmodelworks.com) for full information on this detail-laden kit.

A list of the unique **HO scale** prototype products offered by **Stan Rydarowicz** can now be viewed on the internet. Although Stan does not have a computer and conducts all business via the post office, his friend Jim Hayes has established a web site listing all Stan's products.

For several years, Jim has maintained a product listing for Sunshine Models whose owner, Martin Lofton, also declines to climb aboard the internet. To view Stan's products go to [www.sunshinekits.com](http://www.sunshinekits.com) and click on Links.

We salute Jim Hayes of Portland, Oregon, who says he maintains the site for the benefit of his fellow prototype modelers.

A quick review of **Rapido's** ([www.rapidotrains.com](http://www.rapidotrains.com)) production schedule shows their **HO scale** wide-  
vision steel caboose decorated for Algoma Central (red body, black roof)



**FIGURE 8:** Micro-Trains ([www.micro-trains.com](http://www.micro-trains.com)) has two heavyweight RPO cars with six-wheel trucks painted standard Pullman green with black roofs. One car is lettered for ATSF while the other is unlettered (above) and ready for decaling in your choice of roads. Also new from the Oregon-based **N-scale** specialist is a Canadian Pacific 50-foot rib-side plug-door boxcar and a 33-foot two-bay rib-side open-top hopper car with a coal load included. The hopper is decorated for Delaware, Lackawanna & Western and features a "Road of Anthracite" herald.

and Ontario Northland (orange body, blue cupola) will arrive at dealers in March. April deliveries will include CP Rail (yellow body) and Canadian Pacific Railway (white body with red lettering).

**R**obb Thomas of **Prairie Locomotive Works** ([www.prairielocoworks.com](http://www.prairielocoworks.com)) has been showing a pre-production sample of his new **On30** scale 15-ton bottom-dumping ore car at various winter shows. Packaging and other final details are pending on the RTR injection-molded model that will be priced at \$40 with free delivery to domestic locations. Robb says the new model should be ready for release later this month.

**S**ylvan Scale Models ([www.isp.on.ca/sylvan](http://www.isp.on.ca/sylvan)) showed its new **HO scale** CN and CP 1950s-era piggyback trailers at the Copetown Show late last



**FIGURE 9:** Glenn Guerra built this **O scale** 28-foot Chicago Burlington & Quincy caboose from a kit available direct from Mullet River Models ([www.mulletrivermodelworks.com](http://www.mulletrivermodelworks.com)). The model replicates older Burlington class NE1 and NE4 cars that were rebuilt with steel underframes. The kit features laser-cut plywood construction with working side and cupola windows. The underframe and ladder sides are etched brass.

month. Also on display at the Canadian event were the new Mack B-61 single and tandem axle day-cab tractors based on prototypes produced by Mack Truck from 1953-1965.

A favorite among other vehicles at the show was a Plymouth sedan tricked-out with fender skirts and windshield sunshade. Stock 1946-49 Plymouth 2-door and 4-door sedans and a coupe were also displayed.

**T**ichy Train Group has a USRA twin-bay open-hopper decorated

for B&O. The **HO scale** ready-to-roll model has a black body with white graphics and features wire grab irons, appropriate trucks with metal wheel sets and Kadee couplers. The car is being marketed by InterMountain ([www.imrcmodels.com](http://www.imrcmodels.com)) and may be ordered direct from IMRC or through your favorite dealer.

#### Industry News

**Record Storm Ruins Timonium Show**  
New attendance records were set at the Great Scale Model Train Show



held in early February in Timonium, Maryland, but they weren't the kind of numbers the promoters of the event was hoping for.

The founder and producer of the show, Howard Zane, said the devastating snow storm that hit the Northeast kept both exhibitors and show attendees away in droves. Zane told MRH that just 36 vendors were

able to get through the snow and set up their exhibits on Friday, February 5th. On Saturday only 8 brave visitors managed to get through the storm, a far cry from the 8,000 to 10,000 people who normally roam the isles of what is historically the largest model railroad show in the region.

Zane said he and his associates are still trying to determine their loss,



FIGURE 11: This beautifully handcrafted pilot model provides a preview of an **O scale** PRR 4-4-0 class D6 locomotive coming late this year from SMR Trains ([www.smrtrains.com](http://www.smrtrains.com)). A class D6a will also be available. These historically-important locomotives were built during the early 1880s for high-speed passenger service between New York and Philadelphia. The prototype engines were equipped with powered reverse, Westinghouse air brakes and high-speed water scoops under the tender to eliminate time-wasting stops at water tanks. Among the many features of the authentically decorated brass models are moving eccentrics and valve gear, a boiler-mounted Pittman motor and all-metal gears. The 2-rail model is wired for conventional DC operation with a plug-in harness to facilitate use of DCC. Priced at \$1700, expected late this year, the models can be preordered now at a substantial savings. Visit their website for ordering details, technical and historical information and additional photographs.



FIGURE 12: Rail Yard Models ([www.railyardmodels.com](http://www.railyardmodels.com)) has issued an upgraded edition of its previously released **HO scale** Missouri Pacific short bay-window caboose. The urethane kit is based on a prototype built by International Car Company between 1977 and 1983. Among the features of the revised kit are etched metal handrails, narrow draft gear to accommodate Kadee #78 couplers, improved brake detail and assembly instructions on a mini CD with more than 100 step-by-step assembly photos. Also of note are revised Missouri Pacific and MOW decals produced by Rail Graphics. The kit includes trucks with semi-scale metal wheel sets and M.V. Products marker light lenses. Owners of the original version of this kit may purchase the etched handrails as a separate upgrade. Visit [www.railyardmodels.com](http://www.railyardmodels.com) for additional information.



FIGURE 13: Woodland Scenics ([www.woodlandscenics.com](http://www.woodlandscenics.com)) has added this impressive **HO scale** Fire Station to its line of fully assembled, ready-to-use structures. Of special interest are the hinged doors on this handsome Italianate-style structure. Available now at your favorite dealer.

adding that he is hopeful some form of adjustment to exhibitors in future shows can be worked out. One of the exhibitors who made it to the event, MRH columnist Lew Matt, reported that everyone remained cheerful despite their disappointment and pending financial loss. The next Great Scale Model Train Show will be held in Timonium on April 10 and 11, 2010.

### Ride In A Steam Loco Cab

The National Model Railroad Association has announced that the winner of the 75th Anniversary Photography Contest will get a cab ride in a Union Pacific steam locomotive. The NMRA member submitting the winning photograph of one or more models of UP equipment and/or structures in a realistic scene, will win a cab ride in one of the mainline steam locomotives operated by the Union Pacific on the first leg of an excursion in May 2010.

Airfare up to \$500, two hotel nights, and transportation to and from the excursion will be provided to the

winner by the NMRA. For complete details visit [www.nmra.org](http://www.nmra.org) and click on "Win A Day In The Cab." ■

**DISCLAIMER**

The opinions expressed in this column are those of the writer and do not necessarily reflect the opinion of Model Railroad Hobbyist or its sponsors. Every effort is made to provide our readers with accurate and responsible news and information, however, neither Model Railroad Hobbyist or the writer of this column can be held responsible for any inaccuracies or typographical errors that may inadvertently appear in this publication.



**When you see  
this symbol,  
it means:**

**“Click here to  
learn more!”**

**Every click tells advertisers  
an ad in MRH is a wise  
investment ...**



**FIGURE 14:** Trainworx ([www.train-worx.com](http://www.train-worx.com)) will introduce three new 100-ton four-bay open-top hopper cars in July. The N scale ready-to-roll cars will be decorated for Maryland Midland in 12 road numbers, Wisconsin Central with 3 road numbers and 12 numbers for a Flying Rio Grande car with a special Reddy Kilowatt decal as shown above.

## Briefly noted at press time...

... Look for Athearn to release a large selection of new paint schemes on nineteen HO scale products this summer including six locomotives, seven freight cars, three passenger/commuter cars, a MOW crane and two trucks. At the moment the schedule looks something like this:

New livery and road numbers for locomotives including SD60M-SD601, SD45, GP38-2, C44-9W in fantasy roads, F59PH1 with Tsunami sound and Genesis FP7-F7B A&B units decorated for PRR.

New schemes and/or numbers will be available on 40-foot modern boxcars, 50-foot FMC plug-door boxcars, ACF Centerflow hoppers, RTC 20,900 gallon acid tank cars, Coalporters in 5-packs with coal loads, a newly tooled 50-foot PS5344 boxcar and an eastern-style steel 4-window caboose upgraded from MDC tooling. Athearn's venerable railroad crane and tender will be released in five different roadnames.

New Athearn passenger equipment will include 34-foot Overton cars utilizing upgraded MDC tooling in four colorful new schemes and Bombardier Commuter cars in singles and 3-packs for a total of four new car numbers.

Intermodal fans can look forward to a combination of several new names on a 53-foot container and chassis as well as a Kenworth tractor with a chassis and 20-foot reefer-container.

We'll have more details including delivery dates and graphics in the next edition of MRH Newsletter. ■

## About our news and events editor



**Richard Bale** writes our news column under the byline of *The Old Yardmaster*. He has been writing about the model railroad trade for various hobby publications since the 1960s.

He enjoys building models, particularly structures, some of which appeared in the June 2006 issue of *Model Railroader* magazine.



**Send us  
your product  
announcements!**

If you are a hobby manufacturer with a product you want to announce, just [click here](#) and submit your announcement to us!



## Selected Events

### March 2010

CALIFORNIA, STOCKTON, March 13, Winterrail 2010, Scottish Rite Masonic Center, 33 W. Alpine Ave.

GEORGIA, PORT WENTWORTH, March 19-20, Savannah Prototype Modeler's Meet, Port Wentworth Recreation Center. Details from Bob Harpe at [RHarpe@comcast.net](mailto:RHarpe@comcast.net).

MAINE, GRAY (PORTLAND), March 20, 3rd Annual Maine All-Scale Narrow Gauge Show. Information available from [mainenarrowgauge@yahoo.com](mailto:mainenarrowgauge@yahoo.com).

OHIO, CANFIELD, March 25-27, Midwest Narrow Gauge Show, Canfield Fairgrounds. Clinics at Hampton Inn, Canfield. Details at [www.lightirondigest.com](http://www.lightirondigest.com).

OHIO, GREENFORD, March 26-29, All Scales Narrow Gauge Meet, Greenford Christian Church. Details at [www.narrowtracks.com](http://www.narrowtracks.com).

OREGON, ELSIE, March 6, Pacific Model Loggers' Congress, Camp 18 Restaurant (approx. 18 miles east of Seaside). Details at [www.pacificmodel-loggerscongress.com](http://www.pacificmodel-loggerscongress.com).

PENNSYLVANIA, VALLEY FORGE, March 26-28, Railroad Prototype Modelers Meet, Desmond Great Valley Hotel, Details at [www.phillynmra.org](http://www.phillynmra.org).

### April 2010

BRITISH COLUMBIA, SALMON ARM, April 2-4 2010, ShuswapRails 2010, Prestige Harbourfront Resort & Convention Centre. Request information from host Ed Parsons at [mac13@telus.net](mailto:mac13@telus.net).

INDIANA, EDINBURGH (COLUMBUS), April 24, Hoosier On30 Meet, Jonson County Park. Details at [www.trainweb.org](http://www.trainweb.org).

INDIANA, SOUTH BEND, April 16-17, Great Lakes Model Railroad Symposium. Request information from Jason at [jmpamtrak@yahoo.com](mailto:jmpamtrak@yahoo.com).

NEVADA, RENO/SPARKS, April 28-May 2, PCR-NMRA Annual Convention, Nugget Hotel. Information available from Dick Foster at [gate5@att.net](mailto:gate5@att.net).

OHIO, MARION, April 22-24, Central Ohio Prototype Modelers Meet, Marion Union Station. Details from Denis Blake at [dblake7@columbus.rr.com](mailto:dblake7@columbus.rr.com).

OKLAHOMA, TULSA, April 9-10, Oklahoma Narrow Gauge. Details at [www.okng.org/meets/index.htm](http://www.okng.org/meets/index.htm).

OREGON, MEDFORD, April 30-May 1, National Z-Scale Convention, Ramada Inn Convention Center. Details at [www.micro-trains.com/NZC\\_2010.php](http://www.micro-trains.com/NZC_2010.php).

PENNSYLVANIA, MONACA, April 11, Beaver County Spring Model Train Show, Center Stage, 1495 Old Brodhead Road. Details at [www.bcmrr.railfan.net](http://www.bcmrr.railfan.net).

NEW ZEALAND, CHRISTCHURCH, April 1-5, NZ Association of Model Railroad Clubs National Conventions, St. Andrews College, Merivale. Details at [www.gcmrsleeper.org](http://www.gcmrsleeper.org).

### Future 2010

CALIFORNIA, RICHMOND, June 26, Bay Area Prototype Modelers meet, St. David's School Hall, 871 Sonoma Street.

COLORADO, LITTLETON, June 11-12, 4th Annual Rocky Mountain Prototype Modelers Meet, Littleton Baptist Church, 1400 W. Caley Avenue. Details at [www.rockymountainprototypemodelers.org](http://www.rockymountainprototypemodelers.org).

CONNECTICUT, COLLINSVILLE, June 4-5, New England Prototype Modelers Meet, Canton Community Center. Details at [www.neprototypemeet.com](http://www.neprototypemeet.com).

ILLINOIS, NAPERVILLE, October 21-24, Naperville RPM Meet, Naperville Holiday Inn.

KANSAS, BENTON, November 6-7, Mid-Continent Prototype Modelers Meet, Benton Lions Community Center, 150 S. Main Street. Details at [www.midcontinentprototypemodelers.org](http://www.midcontinentprototypemodelers.org).

MASSACHUSETTS, MANSFIELD, Nov 10-14, Craftsman Structure Show, Mansfield Holiday Inn. Details at [www.css2010.com](http://www.css2010.com).

MISSOURI, ST LOUIS, September 1-4, 30th National Narrow Gauge Convention, St Charles Convention Center. Details at [www.30ngconvention.org](http://www.30ngconvention.org).

NORTH CAROLINA, HICKORY, September 7-10, 2011, National Narrow Gauge Convention 2011.

NORTH CAROLINA, PISGAH FOREST (NEAR BREVARD), October 8-9, Narrow Trak 2010, Transylvania County Recreation Center, hosted by Frank Pearsall.

WEST VIRGINIA, CASS, May 21-23, The 2010 Cass Railfan Weekend, Multiple events, some requiring advance reservations. Details at [www.msrlha.org/greenacre.html](http://www.msrlha.org/greenacre.html).

WISCONSIN, MILWAUKEE, July 11-18, NMRA 75th Anniversary National Convention, details at [www.nmra75.org](http://www.nmra75.org).

WISCONSIN, MILWAUKEE, November 13-14, Trainfest, Wisconsin Exposition Center at State Fair Park. Details at [www.trainfest.com](http://www.trainfest.com).

CANADA, ONTARIO, TORONTO, May 20-23, Canadian Association of Railway Modelers (CAORM), May 20-23, Annual Fest, Lakeshore Campus Humber College. Details at [www.caorm.org/events.php](http://www.caorm.org/events.php). ■

Some of the finest trees in the hobby ...

... available in any scale!

CANYON CREEK SCENICS

canyoncreekscenics.com

click to visit our web site



VOL. 1

\$20\*

Fillmore Yard on  
GEORGE SELLIOS'

HO FRANKLIN & SOUTH MANCHESTER R.R.

Only 36  
cents per  
photo

## Photos of George Sellios' Franklin & South Manchester

- Never-before photographed Fillmore Yard
- Over 50 large high-quality digital photographs

click this button to ...

Download Photos

Instant download!

\*NOTE: George is generously donating a portion of the proceeds from each collection sold to help keep MRH forever free! Thanks, George!

# Model Railroad Hobbyist magazine™

May/June 2010 issue sneak peek ...

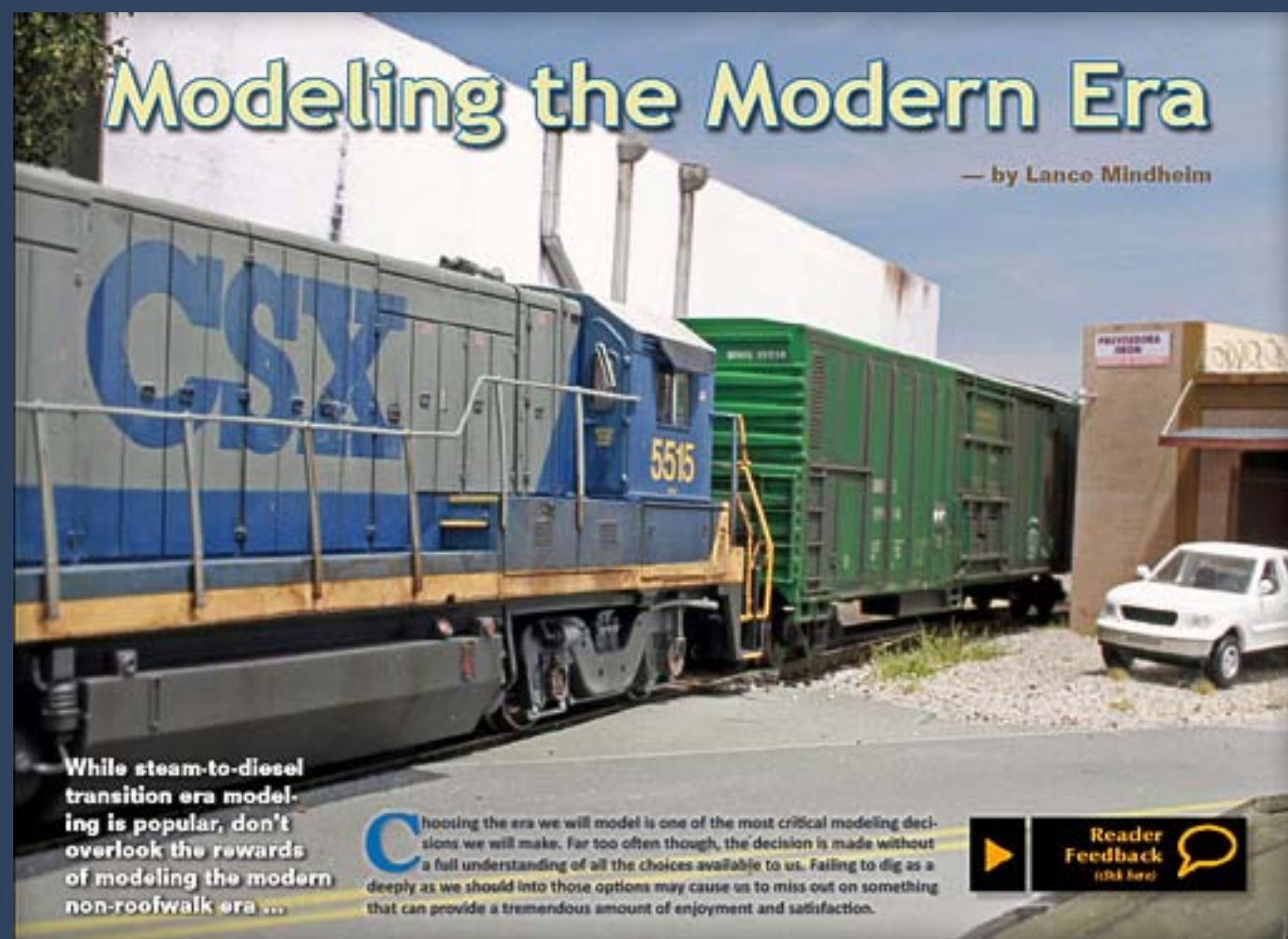

**Modeling the Modern Era**  
— by Lance Mindheim

While steam-to-diesel transition era modeling is popular, don't overlook the rewards of modeling the modern non-roofwalk era ...

Choosing the era we will model is one of the most critical modeling decisions we will make. Far too often though, the decision is made without a full understanding of all the choices available to us. Failing to dig as deeply as we should into those options may cause us to miss out on something that can provide a tremendous amount of enjoyment and satisfaction.

**Reader Feedback**  
click here

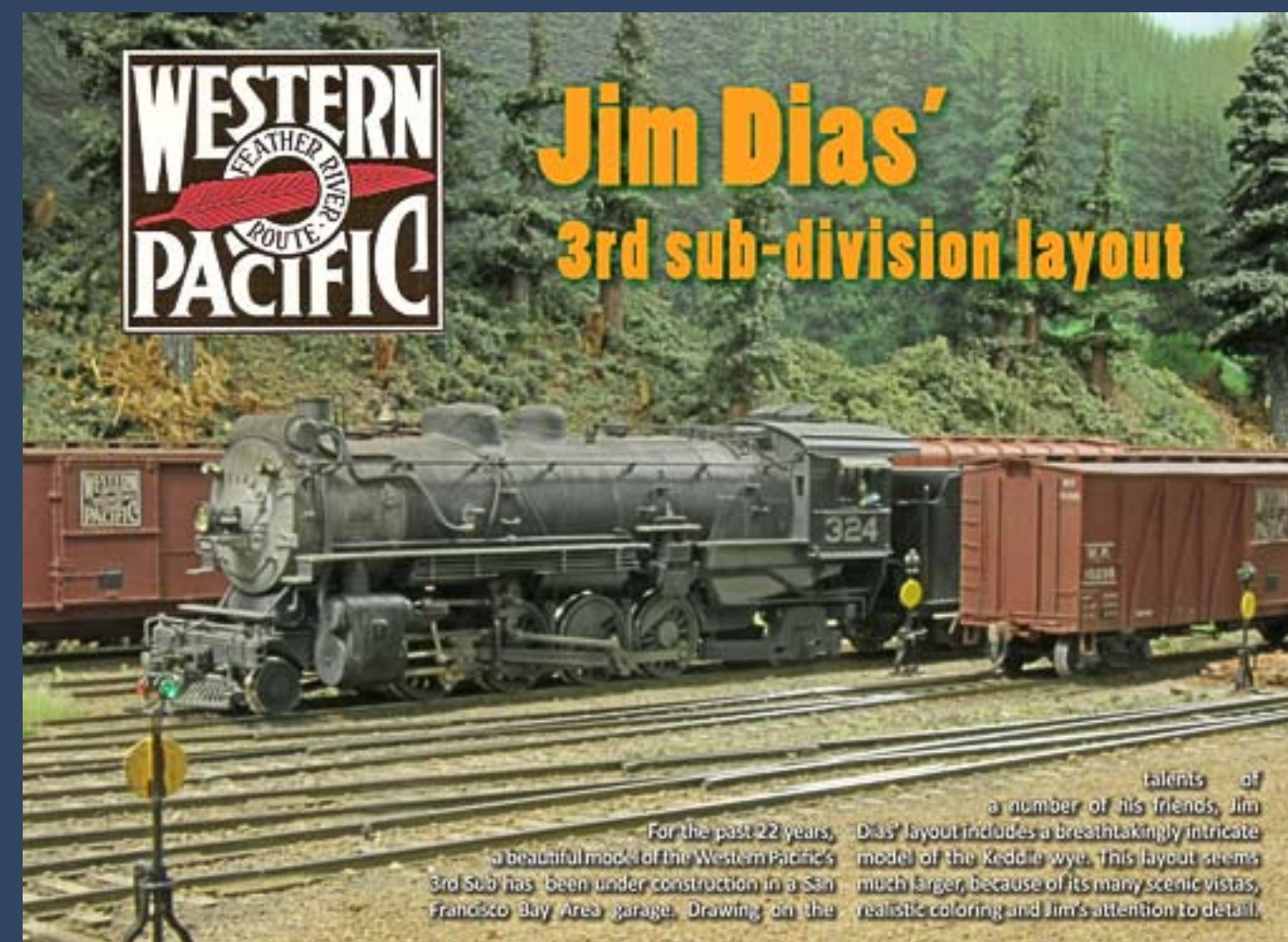

**WESTERN PACIFIC**  
FEATHER RIVER ROUTE

**Jim Dias'**  
3rd sub-division layout

talents of a number of his friends, Jim Dias' layout includes a breathtakingly intricate model of the Keddle wye. This layout seems much larger, because of its many scenic vistas, realistic coloring and Jim's attention to detail.

For the past 22 years, a beautiful model of the Western Pacific's 3rd Sub has been under construction in a San Francisco Bay Area garage. Drawing on the

Subscribe to **Model Railroad Hobbyist magazine™**  
click here

## Model Railroad Hobbyist magazine

The planet's most popular model railroading mediaZine!

Release date:  
May 3, 2010

# MRH

## Questions, Answers and Tips



### QUESTIONS AND ANSWERS

**Q: A friend's layout has 2 reversing loops and he had problems getting them working, although he did eventually figure it out after a lot of frustration. Are reversing loops a good idea? Or should I avoid them like the plague?**

**A:** It's true that reversing loops complicate the wiring of a layout. It's also true that the prototype seldom uses reverse loops.

However, reversing loops can be very handy on a model railroad. They make turning an entire train quite convenient. My previous layout's low-level staging was a giant reversing loop, and the main staging on my current layout is also a large reversing loop.

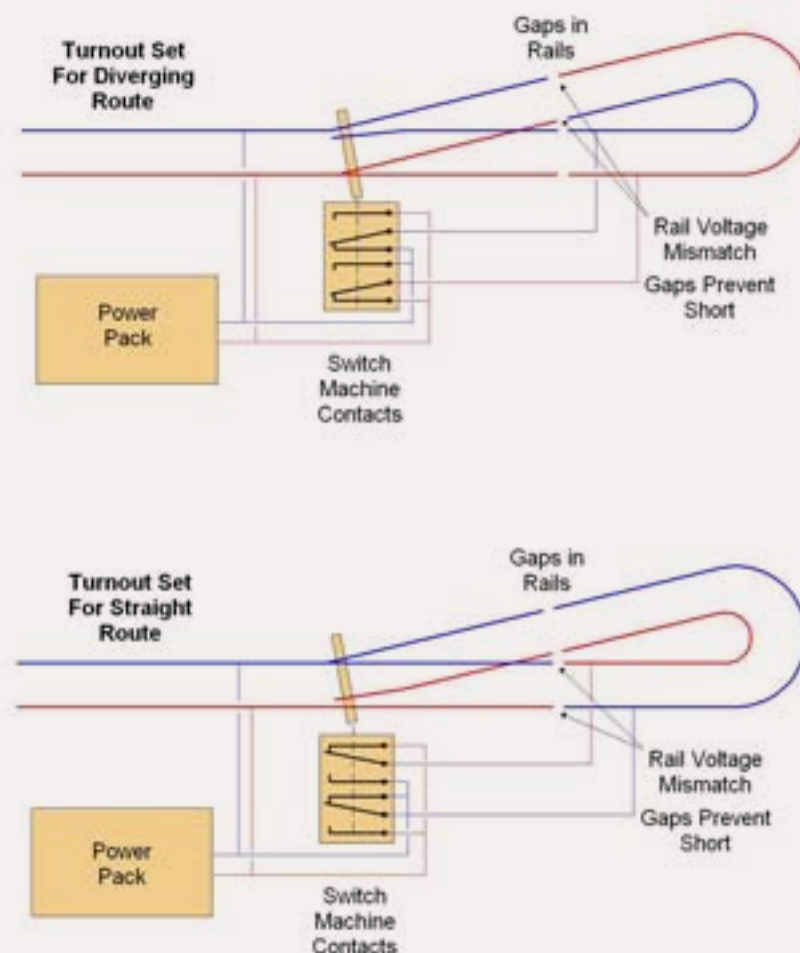

Reverse loops aren't as hard to wire as you might think. You'll need to isolate both rails of the loop tracks to avoid shorts.

You can power these rails through the contacts on a switch machine. If you'll be running lots of locos at the same time inside the loop consider using a relay – the contacts on a Tortoise are only good for 1 amp, while the contacts on relays are good for 10 amps and over.

As you throw the turnout, the contacts automatically reverse the polarity of the loop tracks, allowing a train to pass through the turnout with a short circuit.

If you have DCC you might alternatively consider using what's called an "auto reverser".

These units work by detecting the short circuit that occurs when a train crosses the rail gaps going into or out of the loop tracks and switching the polarity to eliminate the short.

An autoreverser can work in as little as 10 milli-seconds. This is fast enough that the DCC booster doesn't detect the brief short when the lead engine crosses the gaps. — **Charlie Comstock**

**Q: Are there any standards, rules or guidelines for scaling down prototype scenery? My new layout has several sections which are just parts**

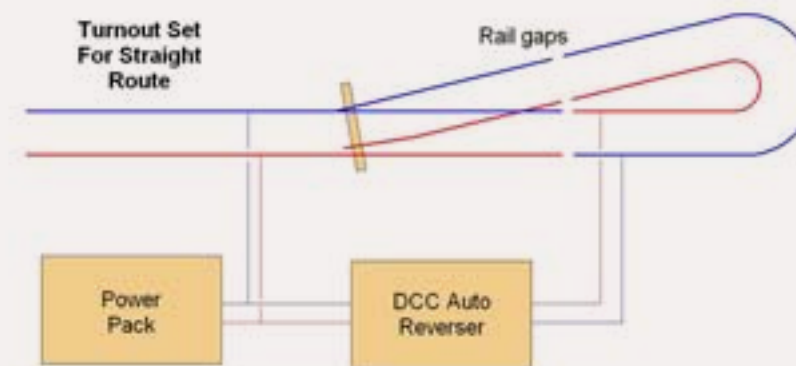

**Figure 1:** Using a reversing loop on a layout means you have to somehow flip the polarity of the rails since the train is turning back on itself and going the other direction. This diagram illustrates the two most common methods: using contacts tied to the throwing of the turnout, or using a DCC auto reverser.

**of real existing areas. How is this typically done?**

**A:** Many modelers seem hesitant to start building scenery, but unlike other parts of the hobby, scenery can be very forgiving. For example, you almost can't make a rock the wrong size - if it's larger than you intended, no problem - it's just a bigger rock.

The best way to start making scenery is to get yourself a book or video about building scenery and gain experience by making some scenery. As to books, Dave Frary's [How to build Realistic Scenery](#) (Kalmbach, 2005) is excellent. Our own [Model-Trains-Video scenery videos](#) are also a good choice - we show you in detail how to go from bare benchwork to a completely finished scene.

A good approach is to start with some photos of a real scene you'd like to model, and then try to match the colors and textures you see in the photos. Using the reference materials we list above, you'll be making hills, streams, roads, and trees in no time - and getting pleasing results using proven methods. **— Joe Fugate**

**Q: I am in the process of designing a layout for my a spare room which has an area of roughly 15'x18' give or take. I am modeling my layout based on a Union Pacific midwest line. Most of the line is flat and doesn't have much up and down contours to it. I don't know whether to use plywood**

**or foam as the base. What do you suggest?**

**A:** Since it sounds like you are going with box-style benchwork, go with the foam.

Few places are 100% flat and foam makes it very easy to carve or stack terrain features – even shallow ones, like ditches alongside the tracks or culverts where a creek passes under the tracks. It also doesn't have splinters or grain, both of which can be annoying problems when working with plywood.

Having said that, I believe the best solution is to combine the two – plywood to give you a solid base for attaching wiring and (if so inclined) turnout machines to, as well as something to keep from ramming your hand all the way through the foam when you accidentally lean on it.

I personally find that 3/8" plywood (circa 10mm metric) works just fine. **— Jeff Shultz**

**Q: I have limited money and space, and I'm trying to choose between N gauge or HO. I've got room for a 4'x8' layout, and I would like to have a medium to long run. What do you advise?**

**A:** My recommendation is for you to choose N scale for the 4 x 8 . For example, take a look at my book [N](#)

[scale Model Railroading](#) (Kalmbach, 2009) and build the Androscoggin Central layout.

The Androscoggin Central is an N scale 4 x 8 designed to represent two railroads crossing at grade with a large industrial switching area served by both.

You'll get a lot of operation in small space with this layout.

**— Marty McGuirk**

If anyone ought to know the pros and cons of fitting an HO or N scale layout into the space, Marty ought to know since he's done both.

If you're really space challenged, N is a good choice. N scale locos these days run every bit as nicely as HO scale locos, and there's lots of variety available in N scale.

The only area where N still has a ways to go compared to HO is diesel switchers or small shortline steam like shays or other geared locos. **— Joe Fugate**

**TIPS**



**Painted text on windows:** Here is a simple, cheap, quick way to make "painted" text on windows with a computer and an ordinary ink-jet

printer. Using Photoshop® I created a mock up of the window art, then

printed it on cheap copy paper, checking the fit and adjusting the point size of the type.

When satisfied, I mirrored or reversed the image. I then substituted a sheet of overhead projector inkjet acetate, purchased at a local art supply store, for the paper. You want the reversed image so that the deposited ink will be on the *interior* of the building and less susceptible to scratching when cleaning the structure.

The only downside issue with this technique is that the ink really needs to dry. Since the acetate doesn't absorb the ink like paper, touching the surface before it is totally dry will result in smudging. **— K. Ferguson**



**Nail polish water:** Here is an easy and inexpensive way to add a realistic small stream to your layout.

Go to any "everything is a dollar" store and buy a couple of bottles of clear nail polish. Since it comes with its own brush, you don't gum up any of your tools and there is no cleanup.



The water on the rock faces shown in the photos is nail polish. The water under the trestle is a thin layer of Woodland Scenics E-Z Water®.

As you can see from the photos, it reflects light nicely for photography. It's also convincing enough to the eye that visitors are surprised when they touch the surface, and it isn't wet! The water on this module is 20 plus years old, so the material lasts. — *K. Ferguson*



## GET \$25 PER TIP

We pay \$25 USD per tip if we publish it. [So send in your modeling tips to Model Railroad Hobbyist](#) and we'll get your payment to you upon acceptance.

Just think, for only a few minutes effort, you could fund your next piece of rolling stock – or even pay for an entire train if you send in several tips and we publish them!

If you include any photos with your tip, we pay a bonus of \$10 per photo we use with the tip. ■



**When you see this symbol, it means:**

**“Click here to learn more!”**

**Every click tells advertisers an ad in MRH is a wise investment ...**

# There are no better Rail History Books for your Library

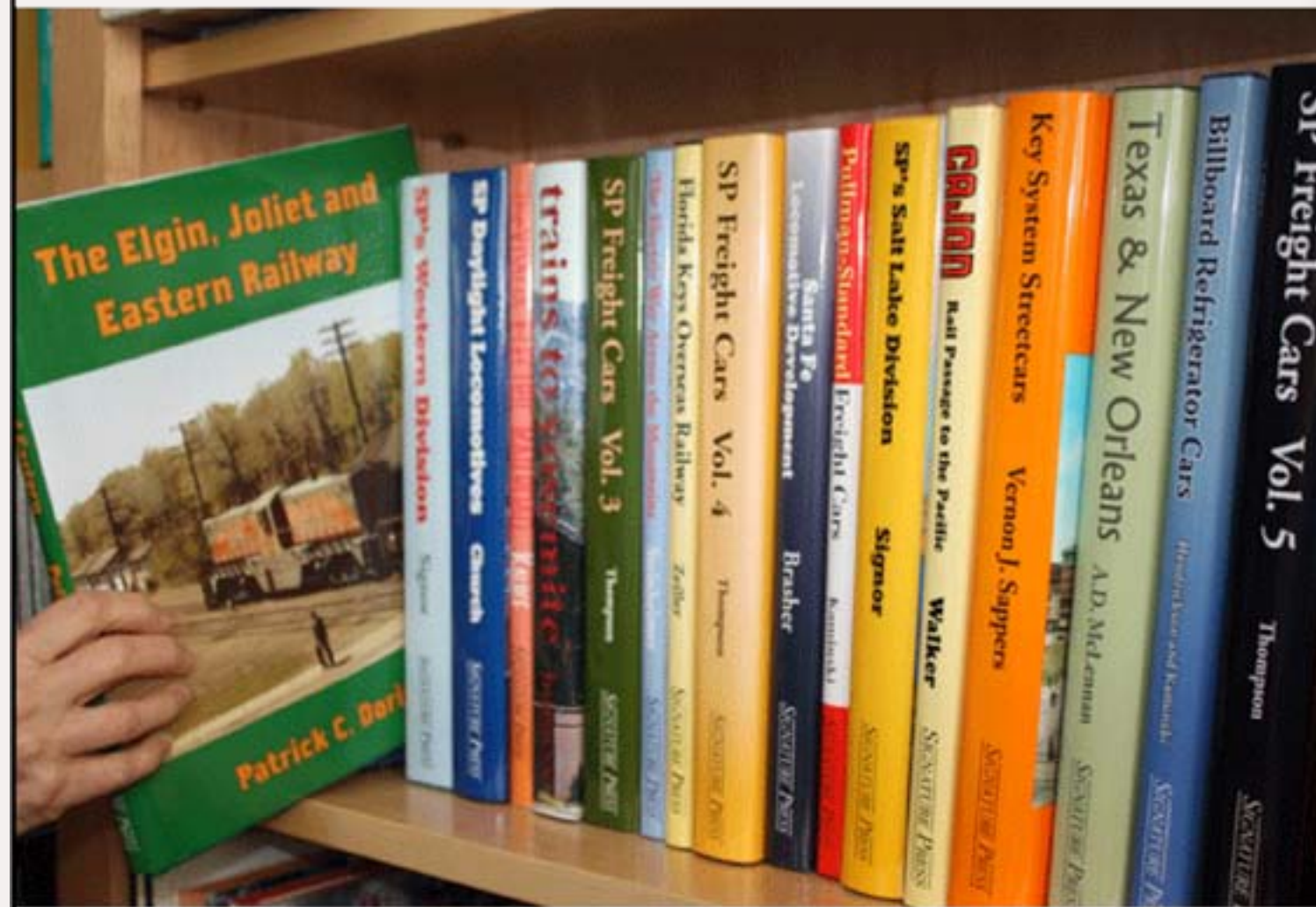

Click here to learn more!

**SIGNATURE PRESS**

Order securely at: [www.signaturepress.com](http://www.signaturepress.com)  
or order direct: 11508 Green Rd, Wilton, CA 95693  
TELEPHONE ORDERS OR DEALER INQUIRIES TO:  
**1-800-305-7942**



see our web site for information on all our books



# Leaving Las Vegas

— by **Bob Sprague**



**What happens in Vegas doesn't stay in Vegas when it comes to the UP's Caliente Subdivision. Here's how to model this Class 1 subdivision in a 9 x 11 spare room – in HO!**



Figure 1: UP 5334 at Apex with a train of windmill towers. Photo: Ken Kuehne.

**T**hey say what happens in Vegas stays in Vegas. But when a crew change happens in Vegas – on the busy Union Pacific Los Angeles to Salt Lake City main line – it means that a long freight headed by bright yellow-and-gray SD-70Ms or C44-9Ws is about to leave Vegas far behind.

The UP's Caliente Subdivision begins just south of town and runs northeast (timetable east) to Milford, Utah. Traffic is heavy and varied. Double stacks, auto racks, coal, and general merchandise consists traverse the line at the rate of about one per hour. Most have three or more road diesels at the head end, testimony to the tough grades in both directions. Foreign power may appear, including an occasional BNSF train taking advantage of trackage rights.

After passing through the shadows of the big casinos, and a relatively straight shot across the valley, eastbound trains encounter a stiff grade, climbing and twisting their way 500 vertical feet in less than 10 miles. This geography makes it possible to squeeze a satisfying HO scale representation of the Caliente Sub into a 9 x 11 foot spare bedroom, where one to three operators can enjoy modern Class I railroading with some industrial switching and a branch line adding to the fun.

## Prototype Action

All UP freights take on new crews in Las Vegas, most at the UP yard offices near Charleston Avenue (Milepost 334.3). Though the tracks parallel the famous Strip, this is a different world: the triple-track mainline runs past industrial buildings, sleazy nightclubs, and dusty storage lots.

As trains head north from the city, the mainline narrows to two, and then one track. It remains CTC territory, single track with sidings, for most of its remaining length. At Valley (Milepost 343.5) there is a small yard serving a container port, auto

unloading facility, lumberyard, and cement plant. A seldom-used branch line to Nellis Air Force Base also leaves the main here.

Leaving the industries and tract housing of North Las Vegas behind, the line climbs into the barren hills that ring the city. At Dike there is a passing siding. By the time trains reach the S-curves and summit at Apex (Milepost 352.7) they have been slowed to a crawl by the 1% grade.

At Apex, a long branch operated by Nevada Industrial Switch (NIS) heads east through rugged terrain to serve the PABCO Gypsum Board plant. North of Apex mainline trains continue

downgrade to Moapa, Nevada, where they begin the long climb to Caliente and Crestline, Utah. They leave the Caliente Sub at Milford, Utah and continue on to Salt Lake.

## Fitting It In

The modeler who wants to run long trains and modern motive power but who has only gained trackage rights to a 9 x 11 foot space faces a challenge. A single loop around the walls results in a run of less than  $\frac{3}{4}$  of a scale mile in HO scale. Reasonably-sized trains will only chase their own FRED (Flashing Rear-End Device) around the room. A twice- or three-times-around scheme lengthens the



Figure 2: A westbound freight pauses just above Tropicana Avenue in Las Vegas. The Rio basks in the sunlight in the background. Photo: R. Christopher Haines.

# TCH TECHNOLOGY

THE INFRARED DETECTION SPECIALIST

**LOW COST HIGH QUALITY**

**CLICK FOR MORE!**

### SENSA BLOC ELITE

- Detects current flow in a given block of track.
- Uses quick plug-in connectors for fast and easy installation to track and throttle.
- Indicates occupancy of an entire block by sensing current drawn by locomotive or lighted car.
- DCC only

### SENSA TRAK II

- Infrared train positioning device useful in showing the exact position of a train in hidden staging yard, tunnels, and hidden siding.
- Detects positioning in visible or hidden areas.
- Detects exact position of train.
- Uses proven IR technology.

(620) 431-7150  
1076 41ST DRIVE  
CHANUTE, KS 66720  
WWW.TCHTECHNOLOGY.COM

mainline considerably, but forces traffic to pass unrealistically through the same towns and scenes more than once every trip.

A double-deck design solves the problem. It doubles the length of the mainline, but maintains scenic "sincerity" as trains traverse each scene only once. A steady grade – like the Caliente Sub includes north of Las Vegas – requires only a two-turn helix at 2% to achieve a decent 16" between levels. Mainline minimum radius can be kept to 27", tight but acceptable for six-axle diesels.

The entrance for trains eastbound from Los Angeles onto this plan for the Caliente Sub is disguised by the Sahara Avenue underpass. They cross the

doorway and pause for a crew change at the UP yard office.

Behind the door is space for the spur at West Mesquite Avenue, which on the prototype serves Nevada Ready Mix, the Las Vegas Review-Journal, and several other industries. These buildings can be represented by minimum-depth flats, while a photo backdrop can stand in for the distant mountains. The viewer is facing west here, and the only casino in that direction from the tracks is the gaudy Rio.

On the lower deck the tracks continue on to Valley, where a selectively-compressed version of the container facility, cement plant, and Nellis AFB branch provide switching opportunities. Fortunately, the orientation of

this plan abides by the general track-planning principle that east should be to the viewer's right. Although the tracks through Las Vegas run south to north, timetable east is properly clockwise. The point-of-view is also consistent with the path of most railfans, who would follow I-15 northward out of town.

The California Portland Cement plant at Valley can help to hide the disappearance of the main into the central peninsula. Within that "blob" a moderate two-turn helix at 2% transitions to the upper level, where the tracks reappear behind a rise and enter the desolate siding at Dike.

The modeler who hates making trees should gravitate to this area

of the country – a few dots of glue and some foliage clumps will represent the sparse vegetation well. Pelle Sjøberg's excellent scenery techniques would certainly apply to this wasteland.

The upper deck grade continues to Apex. The mainline, now near eye level, disappears behind another rise (there are no tunnels in this section of the Caliente Sub) while the NIS branch continues onto the peninsula. The gypsum quarry and PABCO plant are quite discernable on satellite maps, and a picture of the plant can be found online at the "about us" page of [pabcogypsum.paccoast.com](http://pabcogypsum.paccoast.com).

*Continued on page 37 ...*

# A social network that has one purpose...

## To learn from your fellow modeler.

# Modeler's Guild



[www.modelersguild.com](http://www.modelersguild.com)



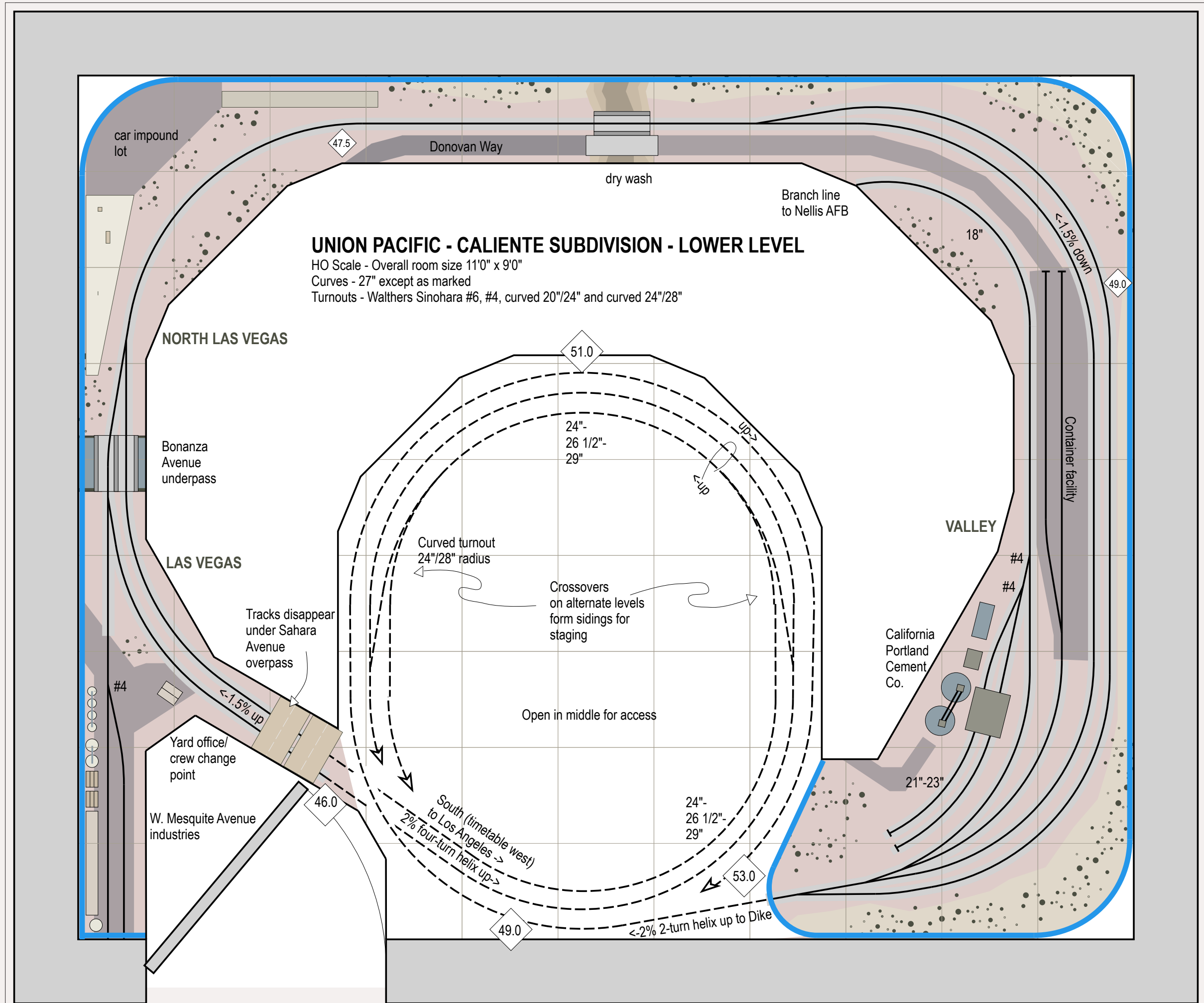

Figure 3: Lower Level of the UP – Caliente Subdivision.

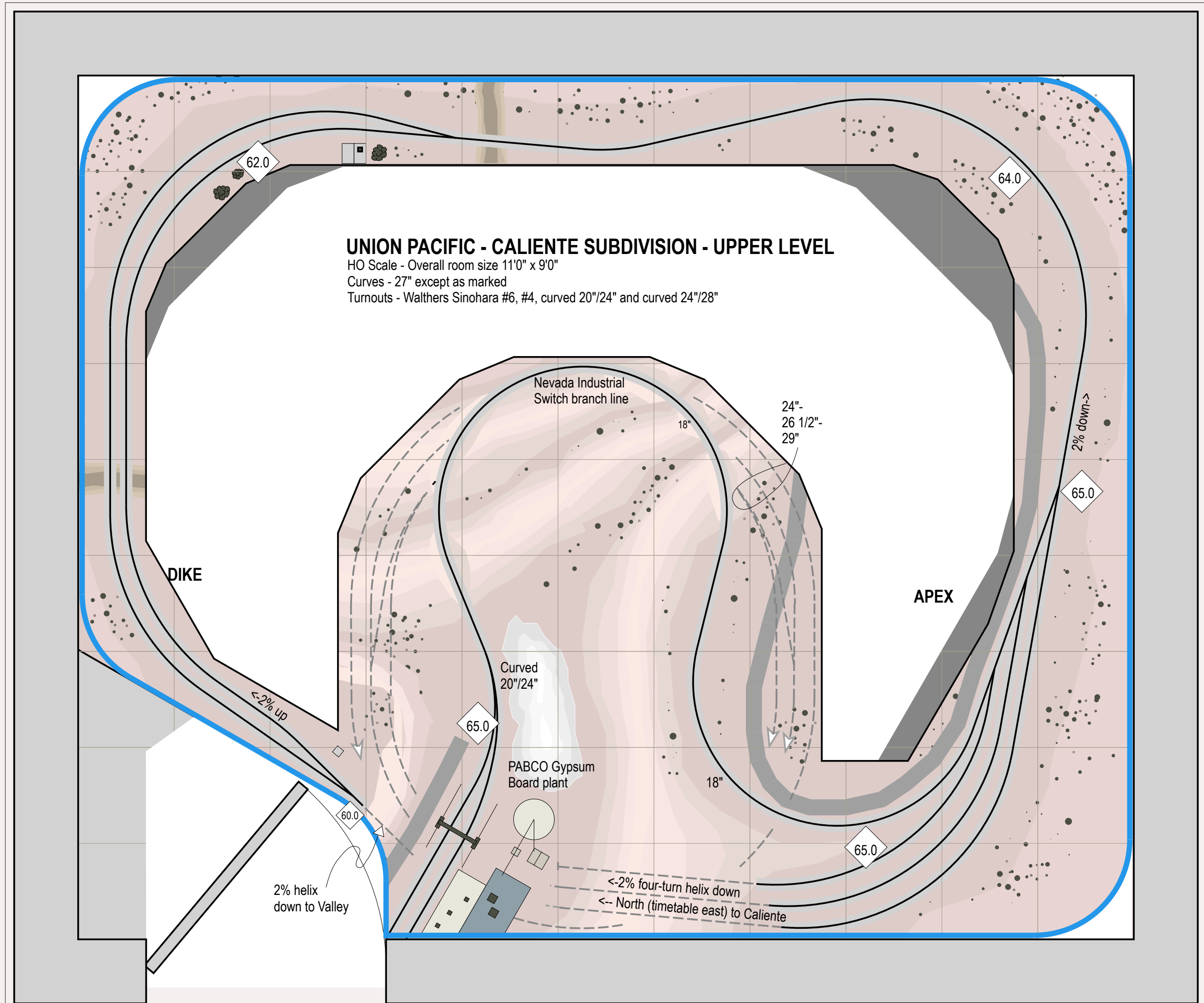

Figure 4: Upper Level of the UP – Caliente Subdivision.

A large, four-turn distended double-track helix connects the north end of the visible Caliente Sub mainline at Apex back to the south end at Las Vegas, providing continuous running. The hidden benefit: the helix provides all of the hidden end-of-line staging a modeler would need. The turns of the helix can conceal as many as sixteen long trains, while alternate facing- and trailing-point crossovers make it possible to stage entrances and exits in random order.

## Construction Thoughts

The Caliente Sub is not for the faint of heart. Considerable care would be

required to construct the center peninsula with its concentric helixes, as well as the upper deck with its constant grade. Still, the rewards of building an operating railroad with this much action and prototype fidelity in a small space could be well worth the trouble.

The stacked decks are narrow, and could easily be supported by brackets from the walls, leaving the under-lay-out space clear of legs and braces. Two legs could support the center peninsula, allowing relatively unimpeded entrance to the interior of the helix complex for access and maintenance.

The bridging of the doorway to the room is an unfortunate necessity.

Many designs for removable or drop-leaf sections have been published, and it is recommended that a modeler employ one rather than plan on scrambling under the lower deck forever.

The upper-deck crossing can probably be fixed; at 60" it represents a "nod-under" for most visitors. In any case, once inside there is no need to deal with the doorway crossing during normal operation.

DCC is a near-must for this railroad, since a lot of the fun will be in moving heavy traffic in both directions with multi-unit lashups and frequent meets.

Although three operators might represent a crowd in the limited aisle space, a prototypical dispatcher's desk could be placed in an adjoining room.

The truly "wired" modeler could develop a computer program to represent movements on the eastern leg of the Subdivision, with actual trains coming on and off the model pike in synchronization with their virtual counterparts on the dispatcher's console.

A similar high-tech approach could help track train movements in the hidden helixes. A simpler solution, however, might be to simply open some vertical slits in the fascia around the center peninsula. An operator would get a peep through, and in this way be able to verify that trains are parked in the clear, or are still moving. This direct visual feedback would help to prevent the well-known phenomenon that occurs when operators, unsure of what is happening in

a helix, gradually open the throttle more and more, causing concealed trains to "rocket" out of the hidden tracks at the upper end.

The Caliente Sub in HO provides Class I railroading in a modest area. Instead of leaving Las Vegas, the builder may find him or herself returning to Las Vegas night after night. 



**Figure 4: The KG1LA stacker led by three Heritage locomotives rounding the Apex curve on its way to Las Vegas. Photo: Mark Whitt.**



Bob Sprague has been model railroading since he was 5 days old. He presently models the Chessie System in HO modular form, and is an active participant in the NMRA's Potomac Module Crew.

His track plan for a bedroom-sized version of the B&O's famed Sand Patch grade was published in the May 2005 issue of *Model Railroader*. In his spare time Bob is co-owner of a creative communications agency and a writer/consultant for Fortune 500 corporations, associations, and government agencies. He lives in Alexandria, VA.



# Quick and Easy Hopper Loads

by Charlie Comstock

If you're tired of watching empty hopper cars rolling along on your layout here's a quick way to fill 'em.

 **Reader Feedback**  
(click here) 

- I cut 1" thick pink rigid foam insulation to fit inside the hoppers. I slice the foam in half so it's about 1/2" thick. I use a bandsaw, but a jeweler's saw also works for these cuts (Figures 2a,b,c).
- I bevel the top of the pink foam blanks to represent the shape of the top of a coal or gravel load.
- I paint the foam black (or gray or brown depending on the commodity being modeled) with acrylic, not solvent based paint.

Figure 1: Hopper cars, loaded with coal, rolling through Oakhill on my BC&SJ.

- I carefully hot-glue a fender washer to the bottom of the load (don't melt the foam!). This lets me unload hoppers with a strong magnet.
- I paint the top surface of the loads with full-strength white glue and liberally sprinkle on Woodland Scenics coal or ballast to represent coal or gravel.

Figure 2a,b,c: Cutting the foam to length, width, and thickness.

Figure 3: A pair of pink-foam blanks ready for shaping to simulate the crown of a coal or gravel load.



Figure 2a



Figure 2b



Figure 2c



Figure 1



Figure 3



Figure 4

Figure 4: The bottom of the upside-down load shows its fender washer hot-glued in place. The quarter gives an idea of the load's size. These are HO scale.

Figure 5: I use the steel fender washers to make unloading the hoppers easy. No prying, no need to pick up the cars, instead I hold a Kadee under-the-track uncoupling magnet over the load and it pops right out.

After the glue holding the phony coal or gravel in place dries, the load is ready to be placed into a hopper car and delivered where it's needed.

You'll probably need different size loads for different types of hoppers.

No more transparent coal or gravel loads on my railroad!



Figure 5

# The largest selection of scale Model Railroad Scenery Supplies on the web!



Click to visit!







**Changes on George Sellios' fabled**

# Franklin & South Manchester

What does a master modeler do when his famous HO scale layout reaches completion? He makes it even better!

George Sellios has done the unthinkable and ripped apart many sections of his F&SM to bring large runs of previously hidden track into daylight and eliminate sidings that were too far from an aisle for access.

These changes plus the addition of Fillmore yard have made the Franklin & South Manchester even better for running trains.

**M**odel Railroad Hobbyist recently had the opportunity to visit the Franklin & South Manchester Railroad and talk with George Sellios and his friend Thom Driggers.

Interview by Joe Fugate, photos and video by Charlie Comstock.



**Reader Feedback**  
(click here)



For the past 40 years George Sellios, his gorgeous layout, and the craftsman kits he produces under the **Fine Scale Miniatures** label have been synonymous with incredibly super-detailed modeling. His F&SM layout is perhaps the most finely detailed layout ever constructed. There is so much there it's impossible to see it all in a single visit.

George spoke with Joe Fugate of MRH about the origins of *Fine Scale Miniatures* and what he's doing on his layout.

## Getting Started

**Joe:** George, I like to know how people got started in the hobby. What got you into Model Railroading?

**George:** I was about 7 years old when I saw Lionel and American Flyer ads on TV and I just fell in love with miniature trains. I forced my mother (and I do mean forced!) to get me a Lionel train set! From there I went to American Flyer (because of the 2-rail track). I stayed



Figure 2

with that for a few years, then in 1955 I discovered HO scale and fell in love with that size and that's never left me.

**Joe:** So you've been modeling in HO since then?

**George:** Yeah HO, well people won't agree with me, but I think it's the most perfect scale around.

## Fine Scale Miniatures

**Joe:** When did you start Fine Scale Miniatures?

**George:** I was working in Boston at the

Ace Carbon Paper company as a production manager in 1965. I was doing a lot of model building at home, and I brought in a model of a water tank and tool shed and I showed it to one of the guys there and they asked me if I could build a model for them.

That night I went home and I got the idea to do model kits. The original name was Gay 90's Scale Models which I'm glad I changed. In 1967 I ran my first ad in Model Railroader for a Branchline Water Tower and that's where it all started.

**FIGURE 1 (previous page):** Double-headed power upgrade on newly daylighted track behind Franklin.

**FIGURE 2:** Looking down the mainline through Manchester with superdetailing everywhere!

**Joe:** How many kits have you made over the years?

**George:** Oh gosh, it must be close to 70 by now if it isn't 70... it's quite a few.

**Joe:** That's what, a couple kits a year?

**George:** I was doing 2 kits a year and that was between 2,000 and 3,000 of each one. I don't know how I ever

managed all those kits with all those castings but I did it.

Now I'm down to one kit a year and the run is about 500 to 800 kits. They usually sell out pretty quick.

**Joe:** You've been doing dioramas for over 20 years and you're going back to just single kits. Why is that?

**George:** Well, everything revolves around my layout and I just don't have any more room for those huge dioramas. Not only that, I get phone calls from guys telling me they just don't have the room for these huge dioramas

either. I'm really excited about going back to smaller buildings, but there will be beautiful single structures like I originally started with a long time ago.

**Joe:** I can see some advantages, if you have one structure to build, you can put a lot more care into it making it a really nice structure - you're focusing on just that structure. If you've got a diorama there's a desire to get the whole diorama done and you rush through it more than you should.

**George:** Well, its overwhelming for a lot of guys when they see up to six build-



Figure 3

**FIGURE 3:** The Mt. Allen trestle. This mountain was named after John Allen.

**FIGURE 4:** A grimy, run down area of Manchester. Some of the HUGE buildings in this town are visible in the background.

ings to put together - it's like building a small layout. Some dioramas I see out there are huge and I think there's going to be appreciation for these smaller buildings. So let's wait and see.

## The Layout

**Joe:** What lead you from kits to the F&SM layout?

**George:** I don't how it got started!

**Thom:** You had no choice. Everyone was saying you had to build a layout, you're so good at it...

**George:** I just started doing it.



Figure 4

**Joe:** George, what inspired you in your style of modeling?

**George:** I guess John Allen and Frank Ellison. When I started in HO I picked up a book by Frank Ellison, I just loved that guy's writing. He wrote about industry and operation and then I saw the work of John Allen and fell in love with his work. I guess those two guys have done more for me than anybody.

**Joe:** What about the trestle scene [at the end of the middle peninsula], the scenery goes all the way to the floor?

**George:** That's definitely John Allen's influence. In fact it's called Mt. Allen (figure 3).

**Joe:** Now, when you started actually building the layout how did you start?

**George:** Well, I determined the size. I didn't do any track plans. I just determined the size I had and I taped it out on the floor before I put up the bench work. I started with the section over here [Manchester] and took it from there. Once the table was up I started messing around with flex track – just putting it in place to see how it would look. Eventually I had all the track and followed with the buildings and everything.

**Joe:** So you'd actually just experiment with the flex track – different arrangements right on the bench work?

**George:** Yes, I went and put in all the turnouts and everything and laid out the industries and all that. I did have that in mind from the beginning - ev-



Figure 5

**FIGURE 5:** Franklin is a town with much smaller structures than Manchester and Dometown. Again, there is an incredible level of super detailing.

**FIGURE 6:** The pedestrian and auto overpass above Manchester.

everything was done for operation way back then. That's why I have so many spur tracks on this layout. Hopefully, very soon now, we're going to start operating it. Or before I die – you gotta do that I guess.

**Joe:** That's interesting you know, because the big rage these days is 3D computer modeling - actually being able to see what you're planning in 3D.



Figure 6



Figure 7



Figure 8

**FIGURE 7:** The tracks on the left used to be hidden beneath the hills. Making them visible required tearing out the and rebuilding the hills.

**FIGURE 8:** Manchester Harbor.

**George:** I just can't plan it out, I need to have the full-size layout in front of me and work from there using cardboard mockups and all that, placing them in the scene to see what it looks like.

**Joe:** Yeah, once you see it full size, ideas come that you don't even see on paper.

From when you first started to what you now have today, how close is it to your original thoughts?

**George:** Well first of all, I never dreamed it would come out like this! I was planning, believe it or not, a John Allen type layout with scenery down to the floor all around. But I went to Mike Tylick's layout and saw his New England scenery and fell in love with that kind of modeling. Now I'm modeling mostly what I think New England looked like back in the 30's and 40's.

**Joe:** Tell us a little bit about your track work? What kind of track do you use? How do you put it down?

**George:** I use Shinohara code 70 flex track. Before putting it down I nip the ties, so the ends will be irregular when you look down the track.

I have a very strange technique I don't think anyone else has ever done. I put the track in place, carefully lining it up by eye, shimming under it to set elevation and making sure it's perfectly

straight. Then I carefully pour a watery mixture of plaster along the edges of the ties to hold it in place. I mix the plaster in a paper cup. I squeeze the cup making it easy to pour accurately along the ties. It runs right underneath there. That locks the ties right in place. After the plaster sets I'll scrape any extra off the tops of the ties.

The new track behind Belverton – if you saw it while I was working you wouldn't believe it! Little pieces of wood to support the track [until I pour the plaster], all done by eye, just eying up the track and making sure it's straight.

**Joe:** So you're telling me that you fasten the track down with plaster? How thick is the [plaster] mixture, is it real watery?

**George:** It's like cream. I use hydrocal or whatever I've got in hand.

**Joe:** So no nails, no spikes?

**George:** No, nothing but the ballast and the [white] glue helps hold it all in place.

**Joe:** Once the track's down what do you do with it?

**George:** Well after the plaster has hardened, I add all the feeders, then test to make sure all trains run well. Then I paint it and add ballast. If I install the feeders [first] they might have a tendency to pull the track down and I've noticed that whenever you apply heat, you might get a little kink in the rail.

**Joe:** What size feeders do you use?

**George:** 22 and 20 gauge. Mostly 20.



Figure 9

**FIGURE 9:** Wolf Hollow shows that George can build trees and rocks too! The track in background was part of the hidden track daylighting project.

**Joe:** So when you ballast and paint it, is there anything special you do?

**George:** No, I use standard techniques, sprinkle the ballast on, then use watery Elmer's [white] glue and that's all.

**Joe:** What about the track itself?

**George:** I individually paint the ties. I do a small section of track at a time so I'm able to paint each tie railroad tie brown or grayish colors. I use mostly Polly Scale. When it's finished it looks just like it's hand laid (figure 10).

**Joe:** What about the sides of the rails?



Figure 10

**FIGURE 10:** Some of George's highly weathered trackwork in Manchester. Also check out the detail he models in his highways!

layout that was documented by Allen Keller is not the same layout that is here today. What happened?

**George:** Joe, one of the things I did not like about this railroad was the amount

**George:** I have a mixture – I mix rust, roof brown and earth together and that gives me about the same color as the rail I see in my area, the real track, so that's worked out good.

### Changes on the F&SM

**Joe:** George, I know that the original



CLICK HERE

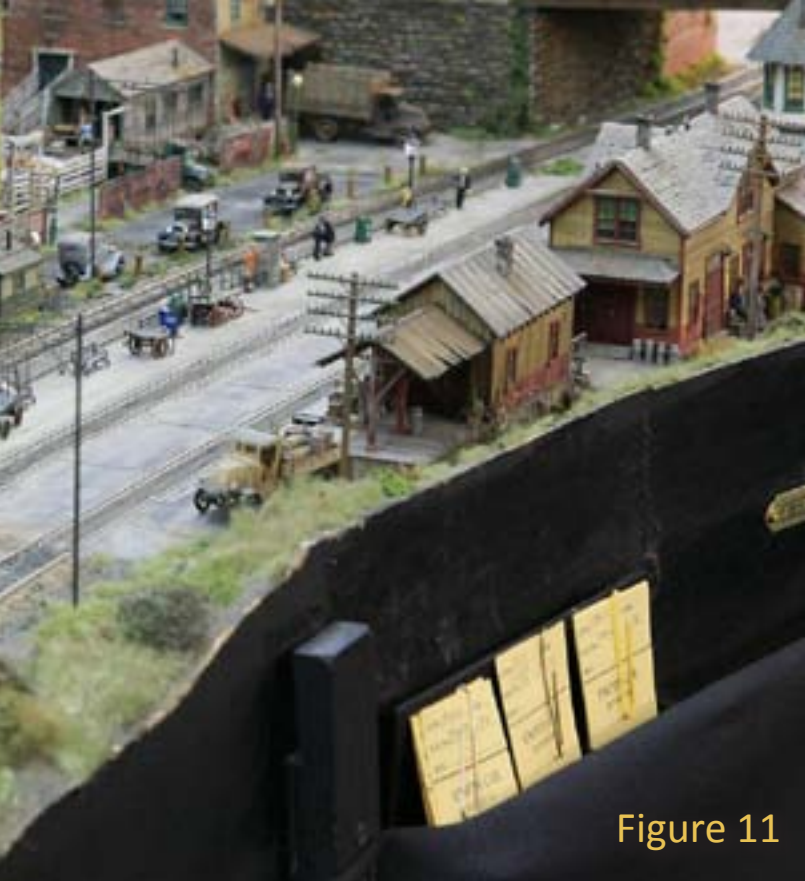

Figure 11

**FIGURE 11: F&SM car cards specify destinations for each car.**

of hidden trackage. I don't know why I ever designed it like that. Recently I've been working at bringing a lot of the hidden track out along the front of the layout. It's been a monumental job but I've done it and I plan to do some more.

**Joe:** I don't like hidden trackage much either – in fact, I've said in the magazine that running on hidden track is like closing your eyes when running trains.

**George:** I agree with that. We've been running a lot of trains recently and now we can see them.

**Joe:** Can you give me an example of one area where you've done that [day-lighted hidden track]?

**George:** The town of Belverton - I moved that track out toward the front of the layout (figures 1 and 7). I even had to elevate it.

**Joe:** What did you have to do?

**George:** One thing I hated to do was removing one of my favorite structures, Duffy's Coal Yard, that had to come out and I had to dig into the mountain quite a bit, then build a grade for the new track and that was really difficult because there was a lot of guesswork! But I finally got it done and everything runs beautiful on it so I'm happy.

**Joe:** Much better than the old, hidden trackage?

**George:** Oh yes. Oh gosh, it just wasn't fun to see a train disappear and not see it again until it came out on the other side of the railroad (figure 12) - under the I.M.Boren building!

**Joe:** I think you were telling me a story earlier while we were talking that a train would go into the [hidden] trackage on one side of the layout and disappear for a long period of time before it would finally reappear on the other side of the layout.

**George:** Well, there were 60 feet believe it or not, where the train would disappear! Now it's down to 20' or so.

**Joe:** So it went from a scale mile of hidden trackage to about 20'?

**George:** Yes, a scale mile. That was ridiculous!

## **Operations are coming**

**Joe:** You mentioned getting started with operation? I've seen some car cards and way bills around the layout



Figure 12

**FIGURE 12: The mainline used to exit Manchester under the massive I.M. Boren building (where the boxcar is spotted). This track was realigned to make it visible.**

**FIGURE 13: George has an artist's eye for large, building-side filling signs.**



Figure 13

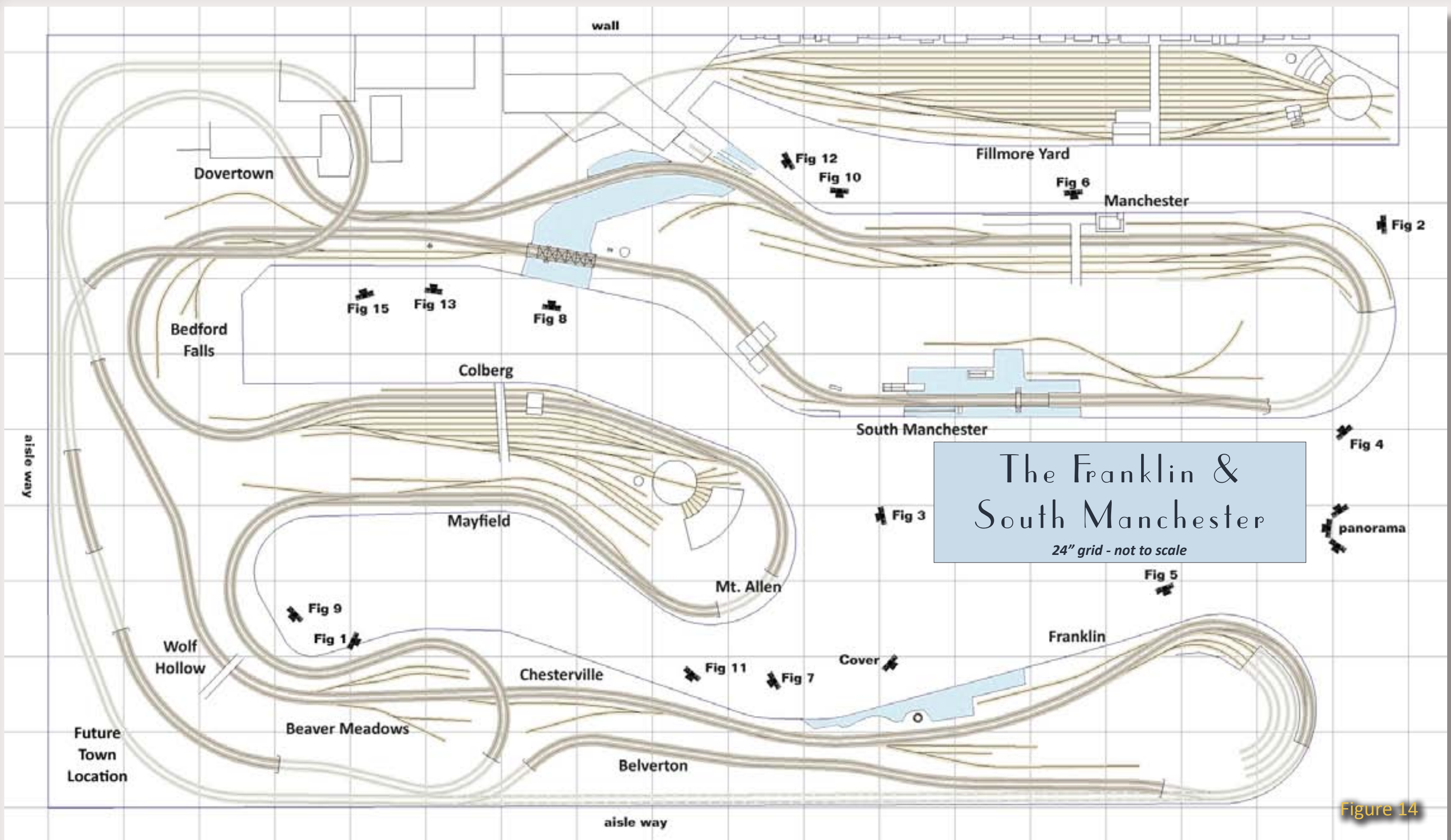

The Franklin &  
South Manchester  
*24" grid - not to scale*

Figure 14

## Layout Summary

**Name:** Franklin & South Manchester  
**Locale:** New England  
**Era:** 1929-1935  
**Scale:** HO standard gauge

**Layout style:** Multi-peninsula, single deck, continuous run, non-walkaround  
**Size:** Roughly 25' x 42'  
**Mainline length:** 300'  
**Min. turnout:** #8 mainline, #6 yards/sidings  
**Min. radius:** 32" mainline, 18" industrial

**Max. grade:** 1.5%  
**Turnout control:** Tortoise and Hanks-craft machines  
**Track elevation:** 43" to 50"  
**Loco control:** NCE DCC  
**Tallest building:** 3' (in Manchester - see figure 4)

**Most windows:** I.M.Boren (2000+)  
**Scenery:** plaster (old areas), foam (new areas)  
**Benchwork:** T-girder  
**Layout age:** Started in 1985  
**Oldest area:** Manchester





Figure 15

**FIGURE 15:** Dovertown used to have many inaccessible switchbacks serving its industries. George tore up the buildings, re-routed hidden track to 'pop out' under the Dovertown station, and rebuilt this area as part of his project to make the F&SM more suitable for operation.

and time table - train order probably is appropriate for your era?

**George:** Yeah. The F&SM ops crew is

setting all that up for me.

**Joe:** It sounds like you've got a knowledgeable crew that will put the whole operation plan together and you're going to just enjoy being part of bringing it all to life.

**George:** Yup, they know a lot more about it than I do. They're all excited and will be coming up here in a couple

of weeks. We're looking forward to it.

**Joe:** That should be a great event!

## Joe talks with Thom

Joe talks with Thom Driggers about operations on the F&SM...

**Joe:** Thom, tell us a little about what's planned for this layout?

**Thom:** Well, George as you know, is a

master artist and the next evolution is to, I think share the layout – get more people over here to actually participate. The next step we've decided to do is to try operation on this layout. It's a wonderful place to be and it comes to life with DCC sound decoders in the locos. We've been working hard the last couple of years to get the layout to DCC wireless, circuit breakers, different block controls and also concentrate on being able to bring it to life with independent operators

**Joe:** What DCC manufacturer?

**Thom:** George likes North Coast Engineering. He tried different ones in the past but NCE seems to be comfortable for him.

**Joe:** NCE wireless?

**Thom:** Yes, their new version. We have 10 throttles, 2 of them are tethered and the other 8 are wireless.

**Joe:** What about the car cards I see in some places? What are you using there?

**Thom:** Well right now we're actually experimenting with a couple of different types. We're in the process of developing the waybills that will determine car routing. We're still experimenting to see how the operators will like it.

**Joe:** Are you using the popular 4-sided waybills that you flip over in the car cards?

**Thom:** I'm not sure exactly who designed it or came up with the idea but

**G**eorge Sellios has been modeling since the mid 1960's. He's world renowned for his Fine Scale Miniatures structure kits and has been working on his famous Franklin & South Manchester layout since 1985. In between he's been married and raised a family (his daughter Tara is an expert photographer). With his railroad nearly complete he turned his thoughts to operation.

For a number of years the F&SM was largely a static display. Now, thanks to the efforts of George, Thom Driggers, and some other friends it's being fine-tuned for operation. This has required finessing brass steam engines and rearranging trackage. In November 2009 Tony Koester, who worked with

Click below for a video clip of MRH's interview with George Sellios at the F&SM.



George enjoying the F&SM inaugural op session with his crew. From left to right: Hal Reynolds, Paul St.Martin, Thom Driggers, George Sellios, Tony Koester, Richard Jocelyn, Dick Ellwell, and Charlie Wallis.

George on his ops plan, visited the F&SM for the inaugural operation session.

George has a web site for his kit manufacturing business - [Fine Scale Miniatures](#).



Tony Koester came over last year and given us a little tutorial on how to possibly attack this problem and Richard Jocelyn has taken it upon himself to give us some help too.

The card for each car will be kept with its car on the layout. The waybills will tell where that car is going next - freight forwarding. The operators will carry the cards for their trains while running them.

**Joe:** What about spotting cars, coupling and uncoupling?

**Thom:** As you know, the layout got heavily redesigned. George has taken out a lot of the areas where you couldn't physically reach cars spotted at the factories [in Doovertown for example - figure 13]. Almost everything is where you can easily get to it. What seems to work best for us at this moment is manual uncoupling by reaching between cars and inserting a [bamboo] skewer in the coupler jaws and uncouple it that way.

George still has [uncoupling] magnets in various sidings where they're a more difficult reach.

**Joe:** Are you planning to use a dispatcher to coordinate trains?

**Thom:** No we haven't gotten to that aspect yet. We're just cutting our teeth on operation, trying to figure if we can even get this to work right because after all it's been pretty much a static model for the last 20 years.

We're just going to see if everybody can come in and get started and move from

point A to point B with a little bit of fun scenery in between.

## Future Plans

**Joe:** George, as someone who's still very passionate about the hobby and really enjoying working on your layout, what plans do you have for the future of the Franklin & South Manchester?

**George:** Well, I'd like to get in a signal system installed and maybe some animations like crossing gates and things like that. But the main thing again, I'd like to get into operation. I've got a crew together now, about 8 or 9 guys, they all know what they're doing.

## Conclusion

**Joe:** You've been in the hobby over 40 years and turned it into a business. How's your passion level these days?

**George:** Oh, it's bigger than ever, especially now with all the new technology - the engines, the steam engines. I love track work, that's my new passion now. I love constantly laying new track on my layout - code 70 - and I still love doing new scenes and all that. I'm constantly replacing sections of the layout and making it better. People can't understand how I can destroy an area but I always make it look better - a lot of guys agree with me on that.

**Joe:** Well, you know the saying that a layout's never finished?

**George:** It isn't if you love doing it! And that's been the case for me, I love working on this railroad. I never get sick of it.



# UP ON THE ROOF

*What you don't see*

– by Tom Wilson  
Photos by the author.

**A prototypical approach to modeling roof top details the correct way!**

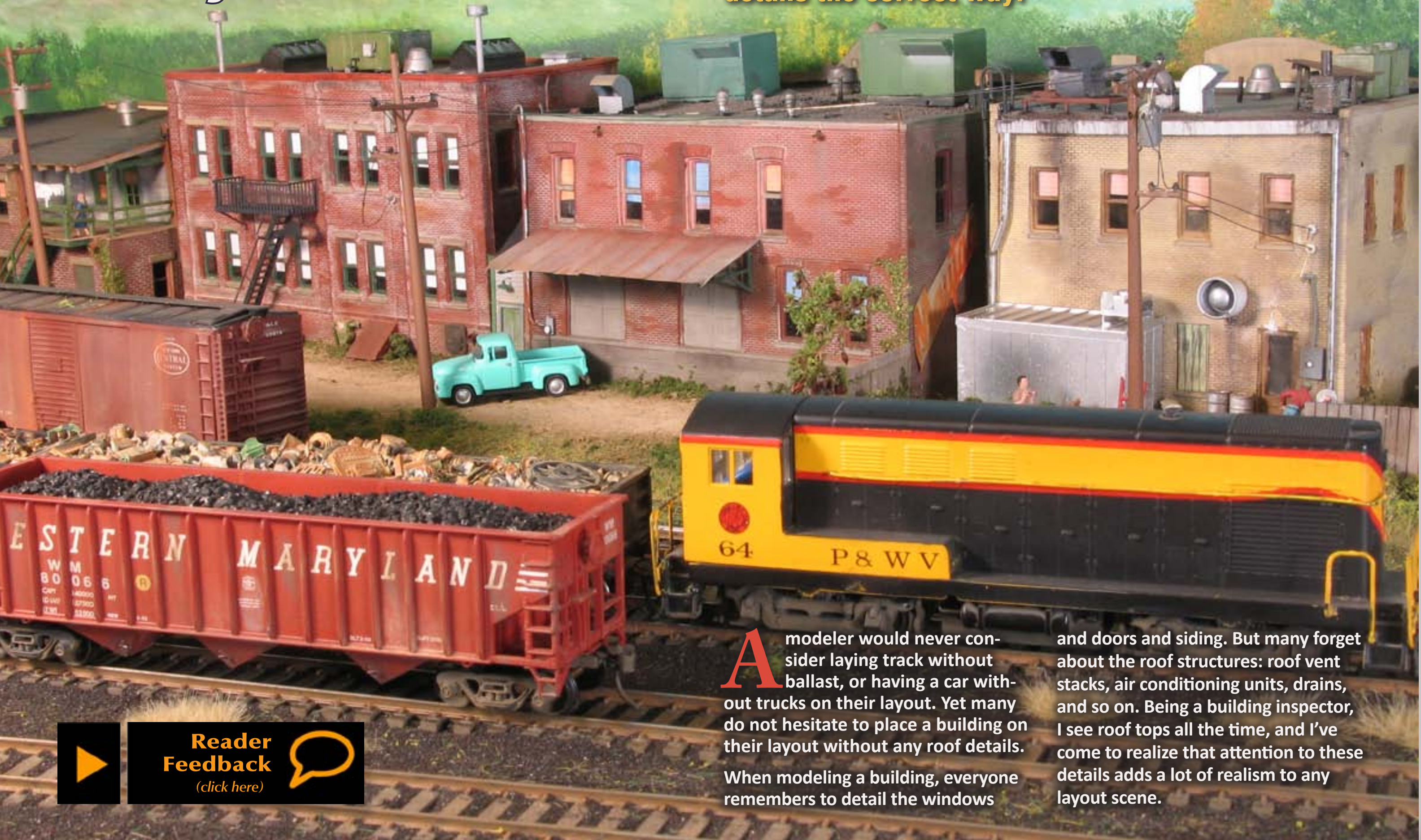

**A** modeler would never consider laying track without ballast, or having a car without trucks on their layout. Yet many do not hesitate to place a building on their layout without any roof details. When modeling a building, everyone remembers to detail the windows

and doors and siding. But many forget about the roof structures: roof vent stacks, air conditioning units, drains, and so on. Being a building inspector, I see roof tops all the time, and I've come to realize that attention to these details adds a lot of realism to any layout scene.

 **Reader Feedback**  
(click here) 

Let's start with a quick course in buildings and roof construction.

There are 3 main building types:

- Industrial (Figure 1)
- Commercial (Figure 2)
- Residential (Figure 3, next page).

The roof styles can be:

- flat
- gable
- barrel (Figure 4, next page)
- shed
- hip

Roof coverings include ([see glossary](#)):

- shingles

- roll-down (Figure 5, next page)
- torch-down
- tar-and-gravel
- tile
- slate (Figure 6, next page)
- wood shake shingles (Fig. 7, page 4)
- metal (Figure 8 page 4)

Items located on the roofs of Residential buildings can be:

- Plumbing vent stacks (Fig. 9, page 4)
- Roof ventilators (Fig. 10, page 4)
- Exhaust vents for range hoods (Fig. 13)
- Gutters (Fig. 14)

*Continued on Page 55...*

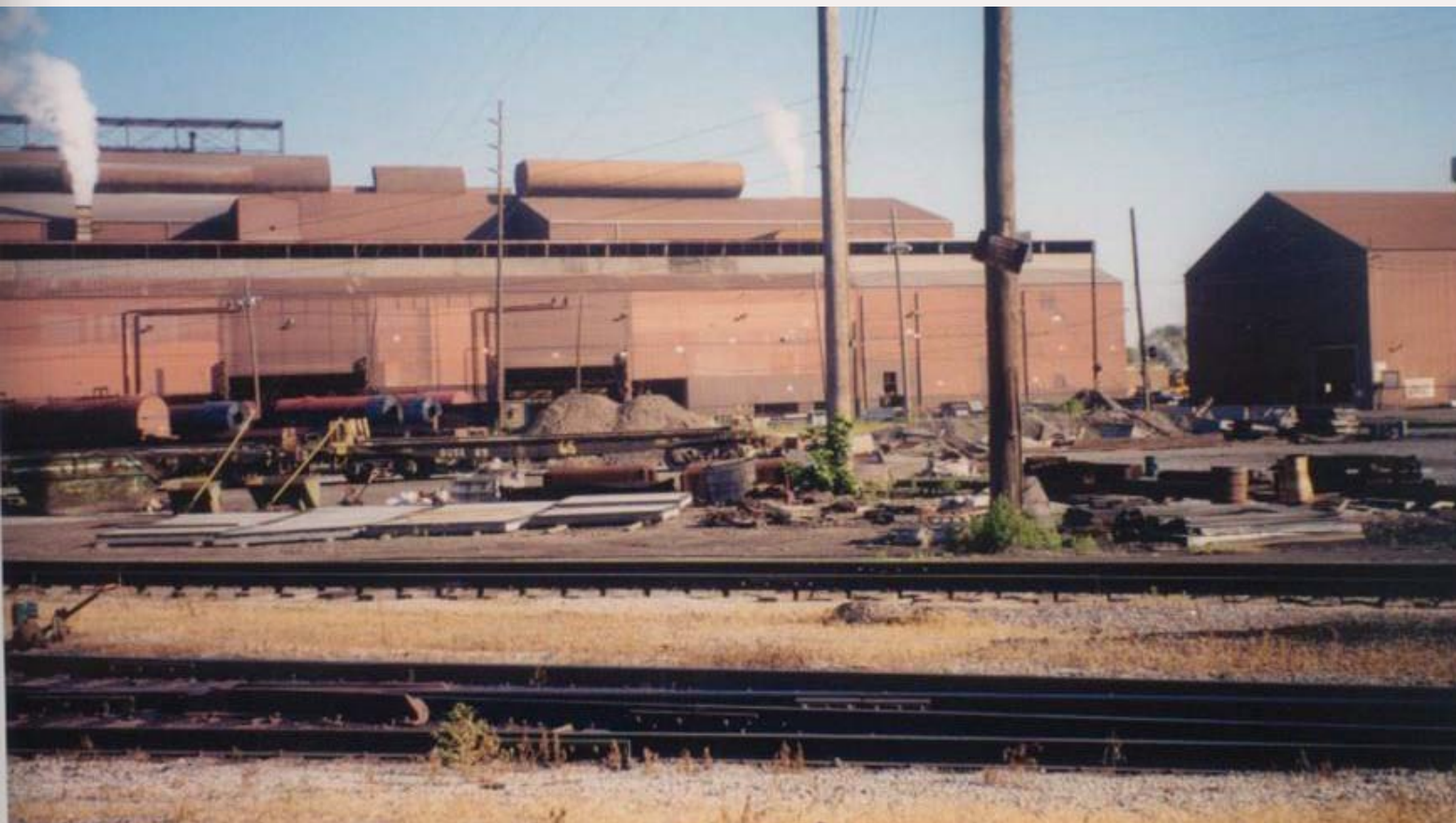

Figure 1: Typical industrial buildings. Notice the large ventilators that let out the heat from processes located inside the buildings.



Figure 2: Typical commercial buildings. Each of these buildings exhibits a different roof type like tile and roll-down roofing. The roof on the right is a gable roof within a parapet wall on the end. From the ground, the roof looks flat.



Figure 3: Typical residential building – a modern house with a tile roof.



Figure 4: This barrel type roof is not as commonly seen, and can be something of a challenge to model. This building is next to Rook Yard of the Wheeling and Lake Erie RR in Pittsburgh.



Figure 5: Here's a combination of different roof types from front to back: roll-down and tar-and-gravel. On the front building, notice the antenna on the roof access and the tile caps on the roof edge. A new cooling tower has been added to the second building's roof. On the rear building, repairs have been made to the roof.



Figure 6: You won't find a slate roof used much in modern construction due to cost. A slate roof will last 50 years or more – this brand-new slate roof was installed to match the original house.



Figure 7: Wood shake roofing is not used much any more. This is a historic house that was restored within the last few years. The new wood shake roof was installed for historic reasons.



Figure 8: This house has a metal-stamped roof . Normally you will see the corrugated type or the standing-seam type. This style was made to look like shingles, but being metal gives better fire protection than shingles.



Figure 9: Vent stacks are normally 3" or 4" in diameter and stand 6" to 18" above the roof, depending on the location of the structure. In the northern climates with snow, the vent will stand higher.



Figure 10: These are typical roof ventilators for a commercial flat roof. They let the heat escape from the attic. Notice the roof heights and types of roofing, and even the tree growing between buildings. Modeling these details from photos will enhance the scenes on your model railroad.

- Antennas
- Chimneys
- Air conditioners (Fig. 13)
- Skylights (Fig. 14)

Items on Commercial roofs can be:

- Roof hatches (Fig. 15)

- Chimneys
- Roof Scuppers (Fig. 16)
- Sanitary roof vents, Air conditioner units, Rooftop furnaces (Fig. 17, next page)
- Refrigeration units for walk-in freezer or refrigerators (Fig. 18, next page)



Figure 11



Figure 12



Figure 13



Figure 14

Figure 11: Typical range hood vent for a flat roof (vent sits on curb).

Figure 12: Copper roof gutters on a residential house. These are new ones – after some years they will age to a nice green patina color.

Figure 13: This is an air-conditioning unit sitting on a roof. The house was built before air-conditioning and was modified to receive the A/C package unit.

Figure 14: Modern skylight. Notice the torch-down roof.



Figure 15



Figure 16

Figure 15: Commercial buildings over 16' high must have access to the roof. This is a roof access hatch.

Figure 16: Roof scuppers. All flat roofs must have a way to get the water off the roof via roof drains or roof scuppers. This roof scupper drains into a pipe that goes to the ground. Scuppers normally are made of galvanized metal, aluminum or stainless steel (this one is stainless steel).

- Grease exhaust fans, up-blast style or utility sets (Fig. 19)
- Makeup air for kitchen hoods (Fig. 20, next page)
- Bathroom exhaust fans (Fig. 21, next page)
- Skylights, old style and new style (Fig. 22, next page)
- Green houses (Fig. 23, next page)
- Roof piping (electrical, mechanical, etc.) Roof drains, primary and secondary, and roof scuppers (Fig. 24, page 8)
- Water chillers and cooling towers (Fig. 25 and Fig. 26 page 8).

Industrial roofs:

- The main purpose is to keep the rain out of the building and off of the processes (Fig. 27, page 9).

- Multiple roof ventilators to exhaust the heat or fumes out of the building.
- Industrial roofs are normally large gable end roofs.

Next, let me show you step-by-step how to install roof details on a commercial roof.

*Continued on page 59 ...*



**Figure 17: These are typical roof-top air conditioning units or furnaces. Note the drains from the units going to the roof gutter. Also notice the vent stacks for the sanitary system. The roof is tar-and-gravel having a turned-up membrane with flashing attached to the wall.**



**Figure 18: Here is a refrigeration unit that has a thrown-together look to it. This picture is the basis for a restaurant refrigeration unit on my layout. Things like this give character to the roof details and are easy to make.**



**Figure 19: These two cooking-pot like vents are up blast grease exhaust fans. These units tilt so they can be cleaned. They stand 40" from the roof surface to the top of the fan.**





Figure 20: Multiple grease exhaust fans on the roof, with a makeup air duct on the wall (green ductwork).



Figure 21: Restroom exhaust fan.



Figure 22: Typical roof details as seen from 1920 through today. This roof has old-style skylights installed (Campbell Scale Models and Grandt Line make this style of skylights). This roof also has old-style roof ventilators with very noticeable weathered streaking. The galvanizing on the smaller pipe ventilators keeps them from exhibiting such strong streaking.



Figure 23: This house roof has a greenhouse. That big gray pipe in the foreground is a vent from a wood-burning fireplace.



Figure 24: This a modern installation on a roof showing :

1. Roof drain. The drain in the foreground is the primary (the stains suggest this). The secondary drain is located behind it and is about 2" higher than the primary drain.
2. The air conditioning condensers are on stands, with the piping on curbs. The dark material on the piping is pipe insulation.
3. The electrical disconnects are mounted on a strut located between the condensers
4. A 4" PVC Vent stack
5. A roof ventilator that is located in the lower right hand corner of the picture.



Figure 25: This a picture of a cooling tower. Piping coming out of the front goes to the chiller located in the building. Electrical disconnect switches are for the fan. The walkway pads protect the roof and the walkway stairs make it easy to access the unit for servicing.



Figure 26: Another style of cooling tower.

Residential building details that are normally located on the roof include a sanitary vent, chimney, and maybe an antenna.

Commercial buildings have more details that can be added. Many of us have the DPM or Walthers storefront building - these structures have a lot of empty space on the roof that's perfect for adding these details.

I've selected an office building and a restaurant to illustrate the process of adding roof details.

You can find the specific detail parts for these projects at your local hobby shop.

I list the specific parts used at the end of this article.

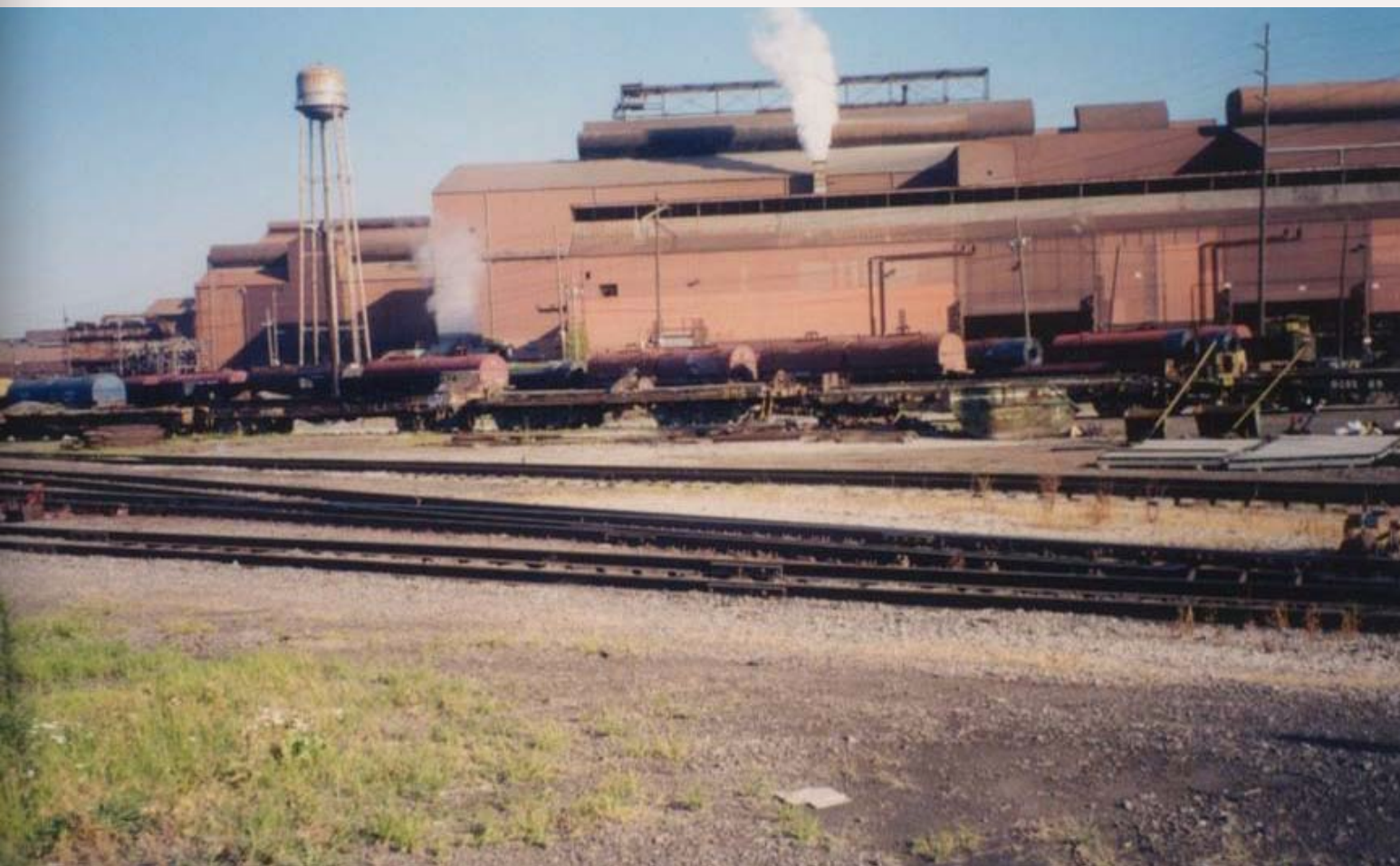

**Figure 27:** An industrial roof serves to keep the rain off the process and let the heat out of the building. This was taken at National Steel, Granite City.

## GLOSSARY OF ROOF TYPES



**Shingles:** Asphalt-coated fiberglass roof covering consisting of individual overlapping rectangular sheets laid in rows without the side edges overlapping. A single layer is used to ensure a water-resistant result. Shingles are laid from the bottom edge of the roof up, with the bottom edge of each row overlapping the previous row by about one third its length.

Historically, at the roof ridge there was a cap consisting of copper or lead sheeting, but in modern times this has been replaced by shingles with a plastic underlay.

The life expectancy of a shingle roof is 15-30 years.

**Wood shake shingles:** A shake is a wooden shingle that is made from split logs. When these are used for covering a house, the result is a shake roof. In North America shakes are typically made from Western Red cedar, while in Scandinavia and Central Europe they are more commonly made from pine.

There are various types of shakes, the main differentiating feature between shakes and other types of shingles is that shakes are split while most shingles are sawn on all sides. The sizes also vary from country to country; in North America shakes are made in 15-inch, 18-inch and 24-inch lengths, with 24 inches being the most common.

The life expectancy of a shake roof is 15-30 years.

**Roll-down:** Asphalt-coated fiberglass or felt available in 3-foot wide rolls commonly used on low-pitch roofs, especially in the inner city, and functions reasonably well. Rolled roofing material comes in 36-inch wide x 50 feet long rolls and is installed with a 2- to 4-inch lap. It installs with very little effort.

Roll-down roofing can last between 6-12 years.

**Tar-and-gravel:** A popular roofing for contemporary homes and commercial buildings with a low slope roof (2:12). Also known as "built-up roofs", tar-and-gravel roofing consist of layers of asphalt and tar paper fastened to the roof surface with molten asphalt applications.

*Continued on next page ...*

The layers are laminated and then covered with gravel to hold them down and protect against UV degradation. Some of this gravel becomes embedded in the hot asphalt, and some remains loose on the roof surface floor.

The life expectancy of tar-and-gravel roofs is approximately 10-20 years.

**Torch-down:** Similar to tar-and-gravel roofing, the torch-down roof consists of layers of fiberglass and polyester with bitumen that are added to the regular tar-and-gravel layering system. These extra sheets are torched-down in the overlap areas during the installation process, using large flame-throwing torches that melt the asphalt at the seams to join them together, which is the origin of the name “torch-down roofing”.

The final result is the vulcanization of a large rubber sheet onto a fiberglass base. Also called modified bitumen, due to the mixing of asphalt with rubber compounds, torch-down roofing provides additional strength and resistance to a flat or low-pitch roof. A torch-down roof is also significantly more attractive than a standard tar-and-gravel roof.

It is not, however, suited to areas prone to high rainfall or snowfall, and has an average life expectancy of about 15 years.

**Tile:** Pit-fired clay tiles have been used for millennia for roofs, and more recently, kiln-fired clay tiles are used. Clay roof tiles are fireproof, waterproof, durable, and can last for centuries. However, because of their weight, they are only suitable for buildings that can withstand the weight of the tiles.

Additionally, clay tile roofs can be expensive and difficult to repair. Various types of tile include:

- Flat tiles - the simplest type, which are laid in regular overlapping rows. An example of this is the “beaver-tail” tile. This profile is suitable for stone and wooden tiles, and most recently, solar cells.
- Imbrex and tegula, an ancient Roman pattern of curved and flat tiles that make rain channels on a roof
- Roman tiles - flat in the middle, with a concave curve at one end at a convex curve at the other, to allow interlocking.
- Pantiles - with an S-shaped profile, allowing adjacent tiles to interlock. These result in a ridged pattern resembling a ploughed field. An example of this is the “double Roman” tile, dating from the late 19th century in England and USA.

- Mission or barrel tiles are semi-cylindrical tiles made by forming clay around a curved surface, often a log or one’s thigh, and laid in alternating columns of convex and concave tiles.

Roof tiles are attached to a roof by fixing them with nails. The tiles are usually put in parallel rows, with each row overlapping the row below it to exclude rain-water and to cover the nails that hold the row below.

The life expectancy of a tile roof can be as much as 50 years.

**Slate:** A natural, metamorphic stone that comes from various geographic regions in Europe, South America, North America. It has two lines of breakability that make it possible to be broken into thin tiles that are durable, very long-lasting, and have extraordinary natural beauty.

When used as roofing shingles, the shingles overlap each other, resulting in half of each slate tile never being seen. Slate roof tiles are usually fixed using either nails or the hook-fixing method as is common with Spanish slate.

Slate is a long-lasting roofing material as it has an extremely low water absorption index which makes it very resistant to frost damage and breakage due to freezing. Chemical sealants are often used on tiles to improve durability and appearance, increase stain-resistance, reduce efflorescence, and increase or reduce surface smoothness.

The life expectancy of a slate roof is 50-100 years.

**Metal:** A roofing system made from metal pieces or tiles. Common materials include stainless steel, copper, zinc, or aluminum sheet, and are inherently durable; the oxidization of the base material forms a protective patina.

Metal Roofing is a very versatile, durable building material. It can be used on residential, commercial, industrial or agricultural buildings. It is not only used in roofing applications, but also may be used as a wall covering. There are many different profiles and styles available to fit most every building situation.

The life expectancy of a metal roof is 20-50 years. ■

## STEP 1: Rook Office Building – Basic Construction



**Figure 30: Basic DPM building with a coat of primer paint on it.**

This building is a DPM kit. Here are the steps I followed:

- Assemble the walls and roof per manufacturer instructions.
- Paint the structure with red automotive primer.
- Paint the windows and then go over the brick with Polly Scale dust wiping most of it off.
- Then give the building multiple coats of India Ink and alcohol wash. I let the structure dry between coats until I was happy with the look.
- Add clear styrene for the window glass. (I used canopy glue to install the window glass.)
- Install the window shades. I made these from white writing paper and glued to the clear styrene on the outside corners. I was careful to not put the glue in the clear open window area. I staggered the shades for a realistic lived-in visual effect.
- I carefully applied Bragdon Powders to the brick in a random fashion.

## STEP 2: Rook Office Building – Roof Details/Cant Strip

As to the placement of details on the roof:

- Vent stacks should be lined up with the brick pilasters located on the outside of the back wall sections between the windows.
- The exhaust fans also should be located there.
- Roof drains are normally located toward the rear of the structure in opposite corners of the roof. The primary and secondary drains are close together so if the primary backs up the water will automatically drain down the secondary. Each drain's discharge is piped separately to the ground.
- If you use the Walthers roof top air conditioner units that come in the roof detail package you will need to keep the air intake away from the vent stack.
- Skylights, roof hatches and air conditioners units can be placed any where.

Now let's start the roof details!

I first applied an initial layer of blue masking tape strips, cut to a scale 3' width.

On the roof between the upright brick and the flat roof I installed a kant strip around the edge at about a 45 degree angle. I used 0.20 styrene, mitered at the corners (Figure 31).

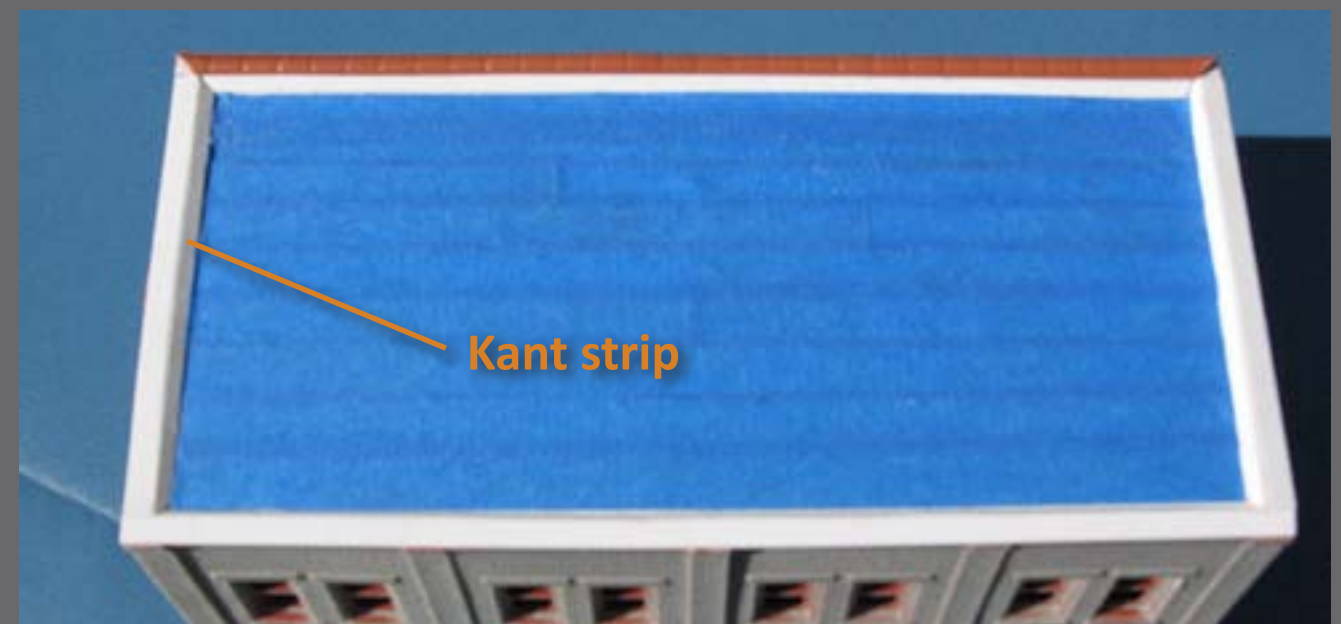

**Figure 31: I applied scale 3' wide blue masking tape for roofing (staggering the end joints like the prototype) and then installed a styrene kant strip angled at 45 degrees.**

### STEP 3: Rook Office Building – Paint and Drilling Holes



Figure 32: I've applied a tile roof cap, added a second layer of roofing over the kant strips, painted the roof cap and the roofing, and drilled holes for the roof drains.

On top of the brick wall section I added a styrene strip just large enough to cover the brick. (#127 Evergreen Scale Models .020x.156.)

I cut tile cap strips from a Plastruct tile sheet and mitered the corners. I painted the tile cap strip with a combination of Polly Scale orange and Polly Scale Special Oxide Red paint. Once the paint was dry, I used canopy glue (see the sidebar) to anchor down the tile strip.

I cut blue masking tape into scale 3' wide strips and applied it over the kanting strips and first layer of blue tape to represent roll roofing. I find the blue tape simulates roofing texture well. Take care when putting the tape next to the tile cap – no gap should show or the roof will leak (Figure 32).

I painted the roof Polly Scale UP Dark gray. I drilled the holes for the roof drains to accommodate the Walthers cyclone roof vents. I started with a small drill and worked up to the final hole size. The vents will be buried half way down in the roof.

### STEP 4: Rook Office Building – Pitch Pockets

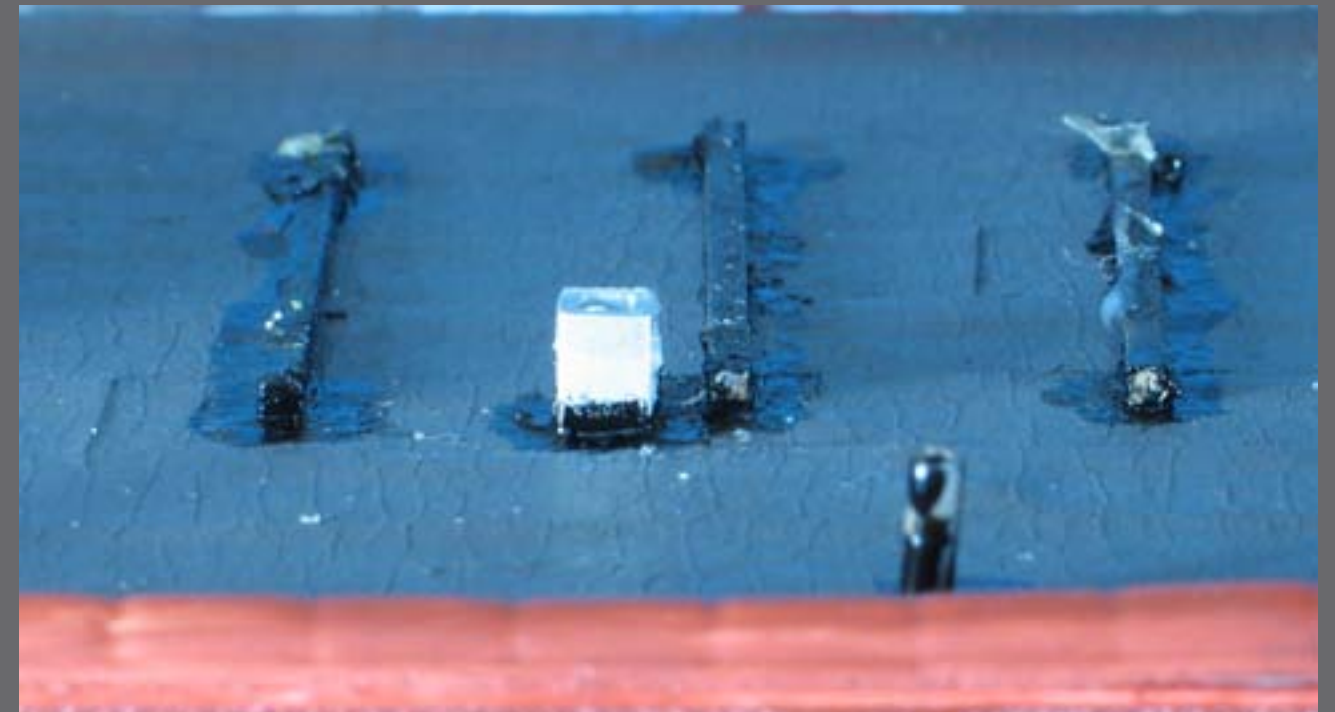

Figure 33: I installed the "pitch pockets" next. *Don't worry about being neat!* The square tubing will receive the refrigerant lines and be filled with tar pitch mixture.

I made three pitch pockets of 4"x4" stripwood and attached them to the roof with a "tar mixture". I made the tar pitch with white glue and Polly scale gloss black, and applied it liberally to secure the stripwood down.

#### CANOPY GLUE:

I sat in on a clinic given by Scotty Mason and he told us about canopy glue. Canopy glue is used by model airplane hobbyists and is made by Pacer Technology, 2004 Rancho Cucamonga, CA 91730. The number that I use is "Formula 560 Canopy Glue." I use it for the following attachments: wood to wood, styrene to wood, styrene to Holgate and Reynolds vinyl siding and brick material, and it can be used for clear window glazing. I found it at my local hobby shop in the model airplane section. I add Poly Scale grimy black paint to the glue to make my tar mixture. Only a drop of paint at a time is needed. ■

## STEP 5: Rook Office Building – Skylights Installed

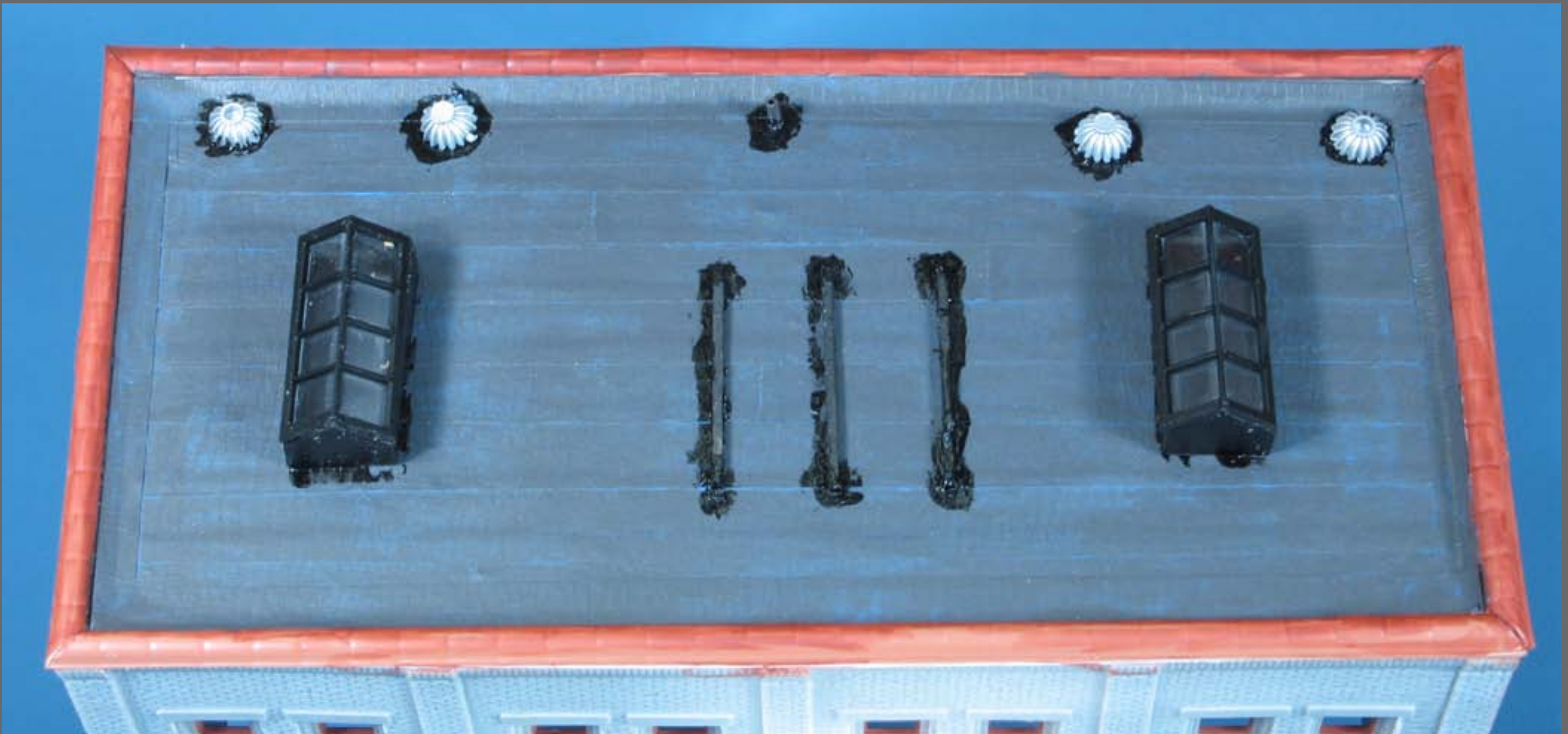

**Figure 34: Skylights and the roof drains are installed. When drilling holes, I was careful to not over-size the holes.**

I've added the skylights and other roof vents, and attached them with the tar pitch mixture.

I drilled a hole to accept the 1/16" brass tubing vent stack, which I painted black. I added some tar pitch around the vent as well.

## STEP 6: Rook Office Building – Skylight Flashing

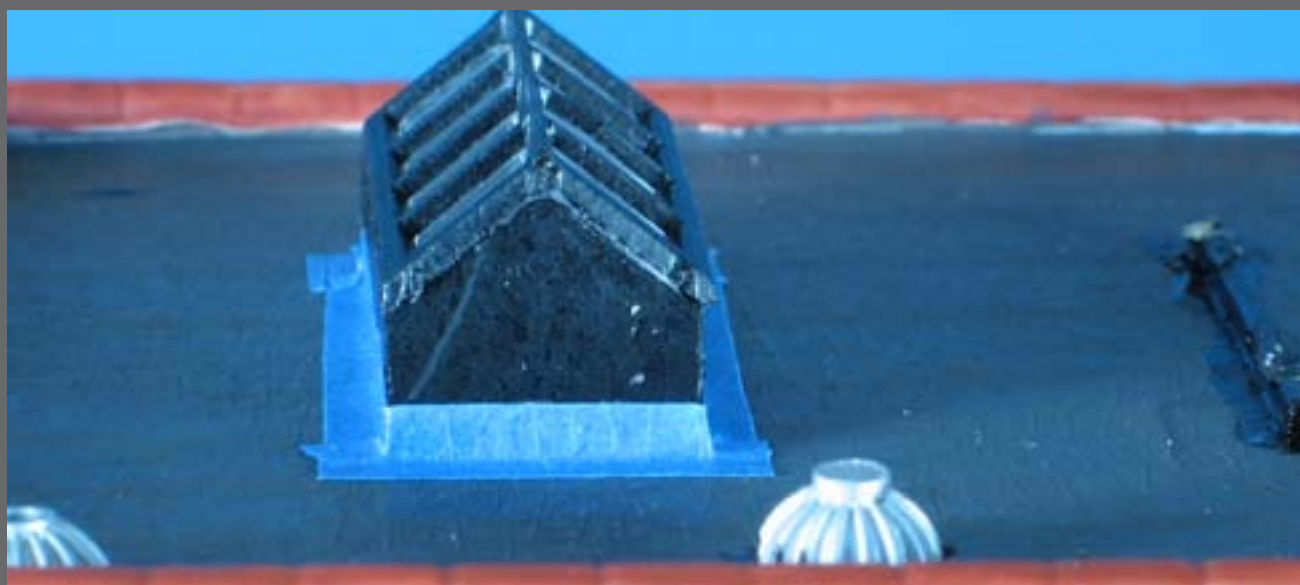

Figure 35: I added flashing around the skylights using blue tape.



Figure 36: Both skylights installed and flashing installed. I started to paint the windows sills with Polly Scale old concrete.

Using masking tape that has been cut scale 3' wide, I fit the masking tape around the skylight as flashing (Figure 35 and 36). I touched up the flashing with the UP gray paint.

## STEP 7: Rook Office Building – Gas Vent Installed



Figure 37: A gas vent pipe installed.

These vent a gas-fired furnace on the lower floors. The vent is from the Walthers roof details #933-3733 "Tall smoke jack with cap". The vent was cut to a length of 7 scale feet. I added the wind screen from a soda straw that is 5/16" in diameter and 1/4 " long. The wind screen was attached with thick ACC glue.

I spray-painted the gas vent assemblies light gray and then installed them onto the roof into some holes I drilled into the rooftop. (Figure 37).



## STEP 8: Rook Office Building – Fans and Vent Stacks

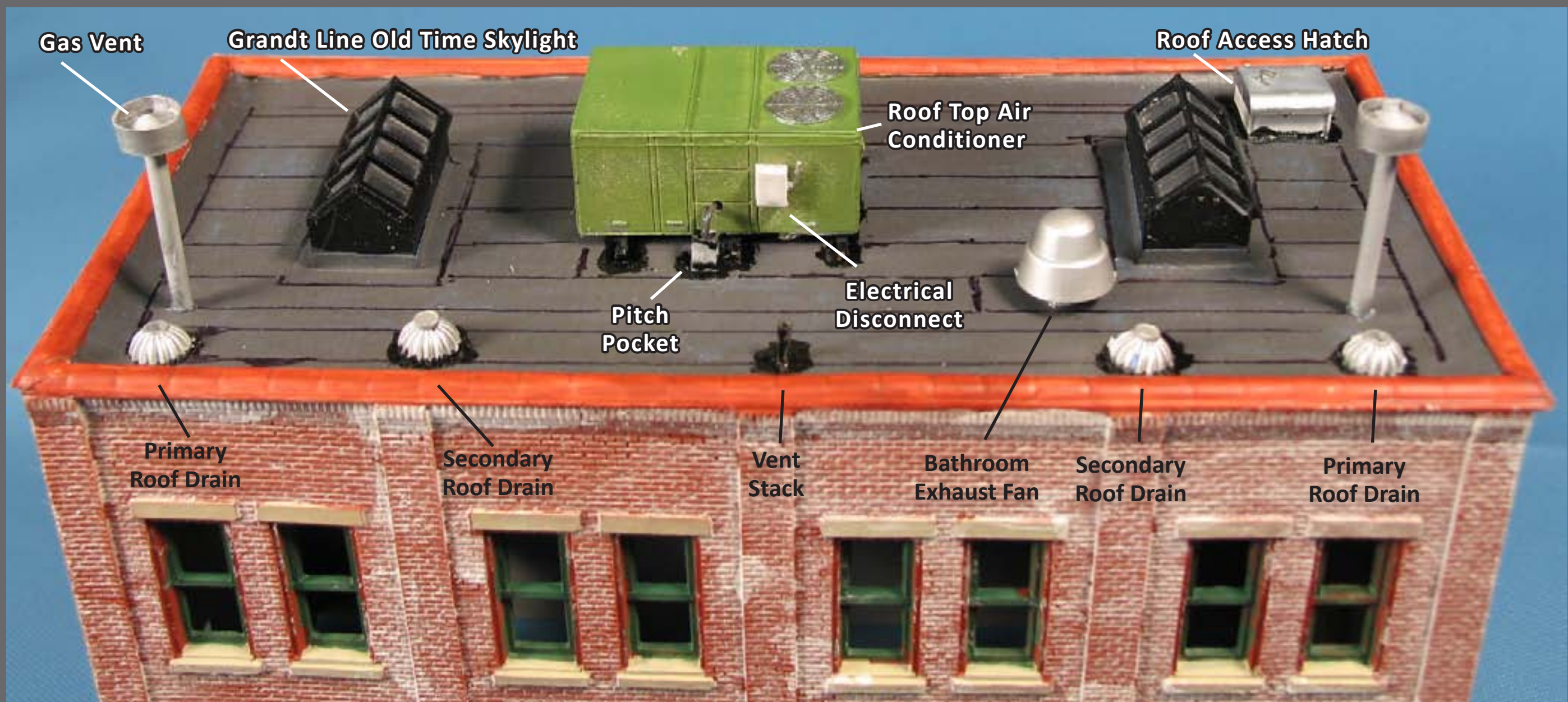

**Figure 38: All the details installed.**

I installed the roof hatch next. I modified it by cutting the bottom off and adding a 2"x12" around the bottom of the vent cover and recessed in about 4 scale inches from the hatch edges. I found this vent cover in the Walthers roof detail package. I attached the roof hatch cover with the tar mixture.

The air conditioner unit needs two holes drilled into the front of the unit so the refrigeration lines will line up with the pitch pocket. The refrigeration lines are bent into a 90 degree angle and are cut to fit between the pitch pocket and the air conditioner. See new drawing. I painted the air conditioner unit and installed it with canopy glue on to the pitch pockets.

I painted a motorized exhaust fan I found in the Walthers modular roof top detail kit a flat aluminum color and added it to the roof. The modular roof detail kit is by Walthers. It has a large assortment of roof details in the package. Part #933-3733 (Figure 38).

Let everything dry.

## STEP 9: Rook Office Building – Tarring the Joints



Figure 39: The top view of the roof joints that I tarred.

The roof covering joints must be “tarred”. I marked these seams with a fine-tip black pen. This represents the tar that comes out of the joints when they installed the roofing (Figure 39). Don’t worry about being neat. Nobody sees the tops of roofs and the contractors normally don’t care either.

## STEP 10: Rook Office Building – Weathering



Figure 40: Final weathering is applied with Bradgon weathering powders.

I used Polly Scale Grimy Black paint to tone-down some of the tarred pitch pockets around the roof details.

I weathered the entire roof and details with a Bradgon weathering black mixture. I dusted the roof, the tile, and the roof drains. I went easy here because it’s easy to totally cover the tar joints, which I didn’t want to do.

This is the completed building roof, done in a prototypically-correct manner (Figure 40).

## STEP 1: Beck's Rook Station Cafe – Cafe 101's

### Roof Top Details Restaurant

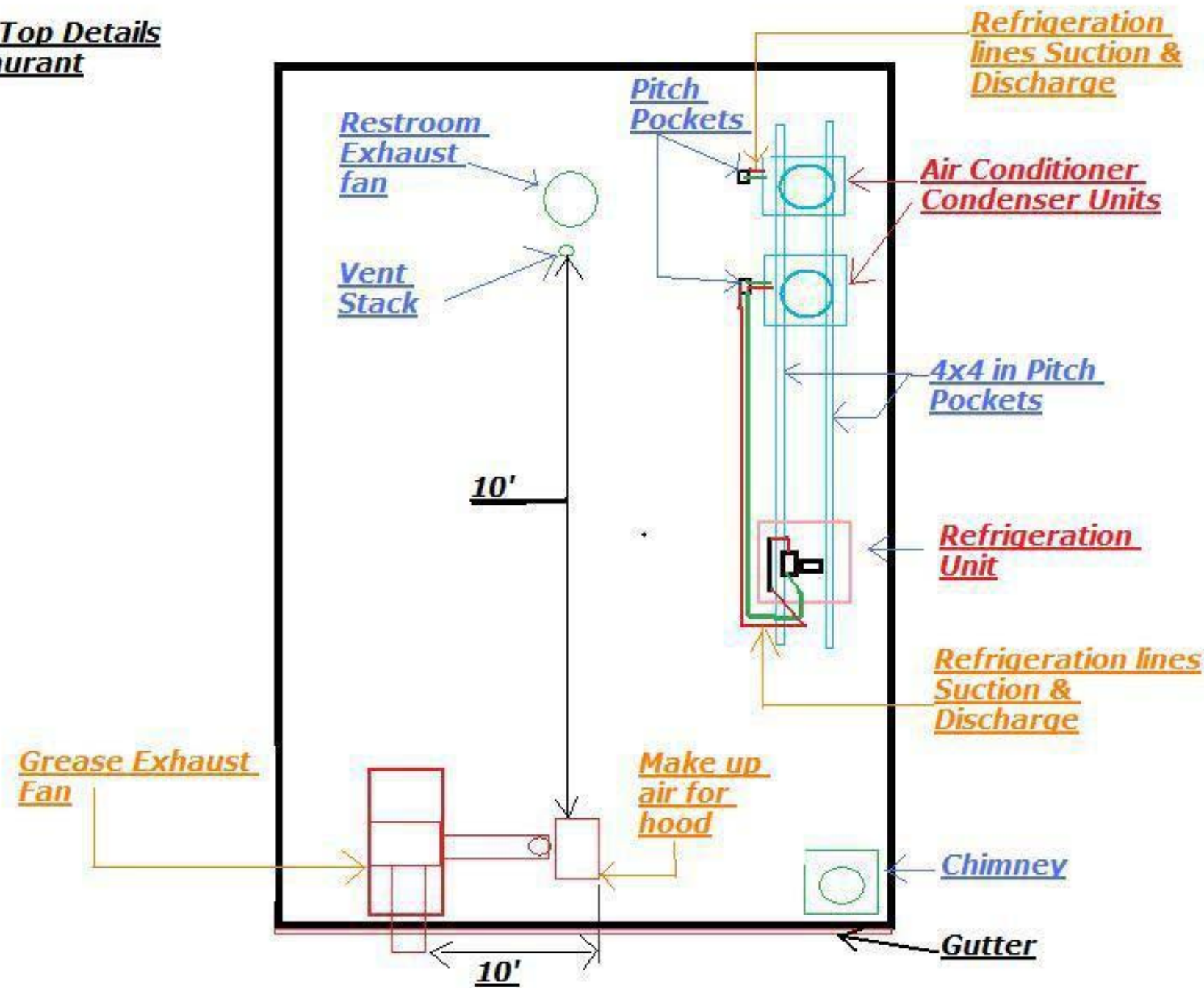

Figure 41: Roof layout of a typical restaurant.

Notice the distances from exhaust fans to makeup air and vent stacks and restroom exhaust fans.

The grease exhaust fan discharge can be vertical or horizontal. I made my exhaust fan to get the visual effect I wanted, with grease coming down the back of the building.

This building started out as a DPM kit. I built the kit to the manufacturer's instructions. I spray-painted the walls a soft yellow to represent a yellow buff brick and painted the windows roof brown. I applied Polly Scale dust and then wiped it off as weathering. I'll do more weathering later.

My Beck's is a restaurant, so the placement of the items on the roof is more critical, with certain distances that must be kept. See the roof layout diagram in Figure 41.



**Figure 42: Description of a prototypical layout of restaurant.**

Figure 42 shows a prototypical layout of a restaurant roof with all the equipment.

## STEP 2: Beck's Rook Station Cafe – Painting and Stacks

Advertisement

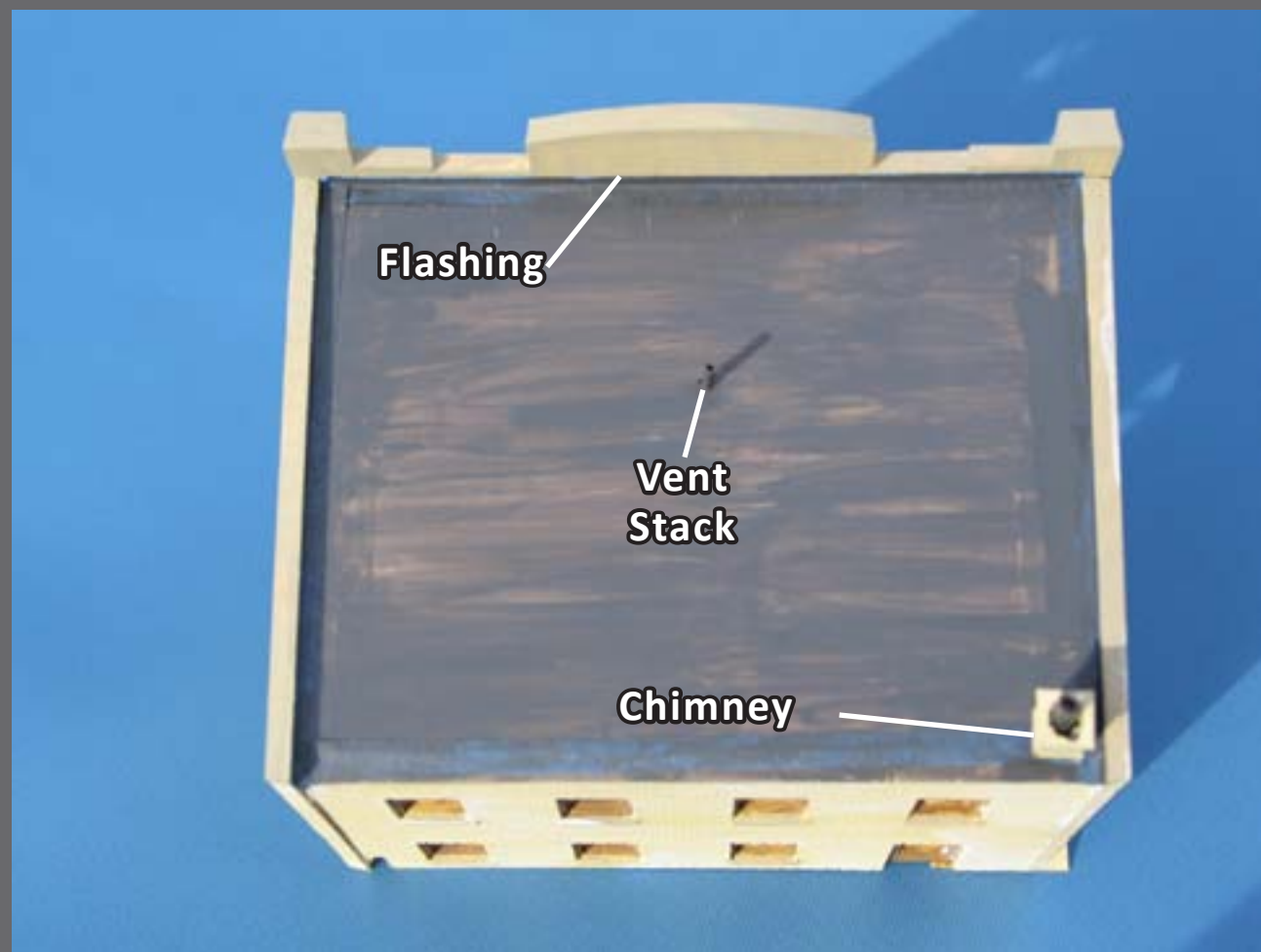

Figure 43: The DPM kit with roof installed and painted. I've installed the flashing, the chimney and the vent stack piping.

Let's apply roof details to Beck's.

I decided to make the roof tar-and-gravel. I painted the styrene roof Polly Scale grimy black to give it a base coat. I kept applying coats as needed until no white was showing through (Figure 43).

Reach over 25,000 model railroaders with your 1/2 page ad in this space for as little as \$245.

Your web site's always just one click away from our ads – talk about *instant gratification!*



[Click to learn more ...](#)

## STEP 3: Beck's Rook Station Cafe – Flashing Installed

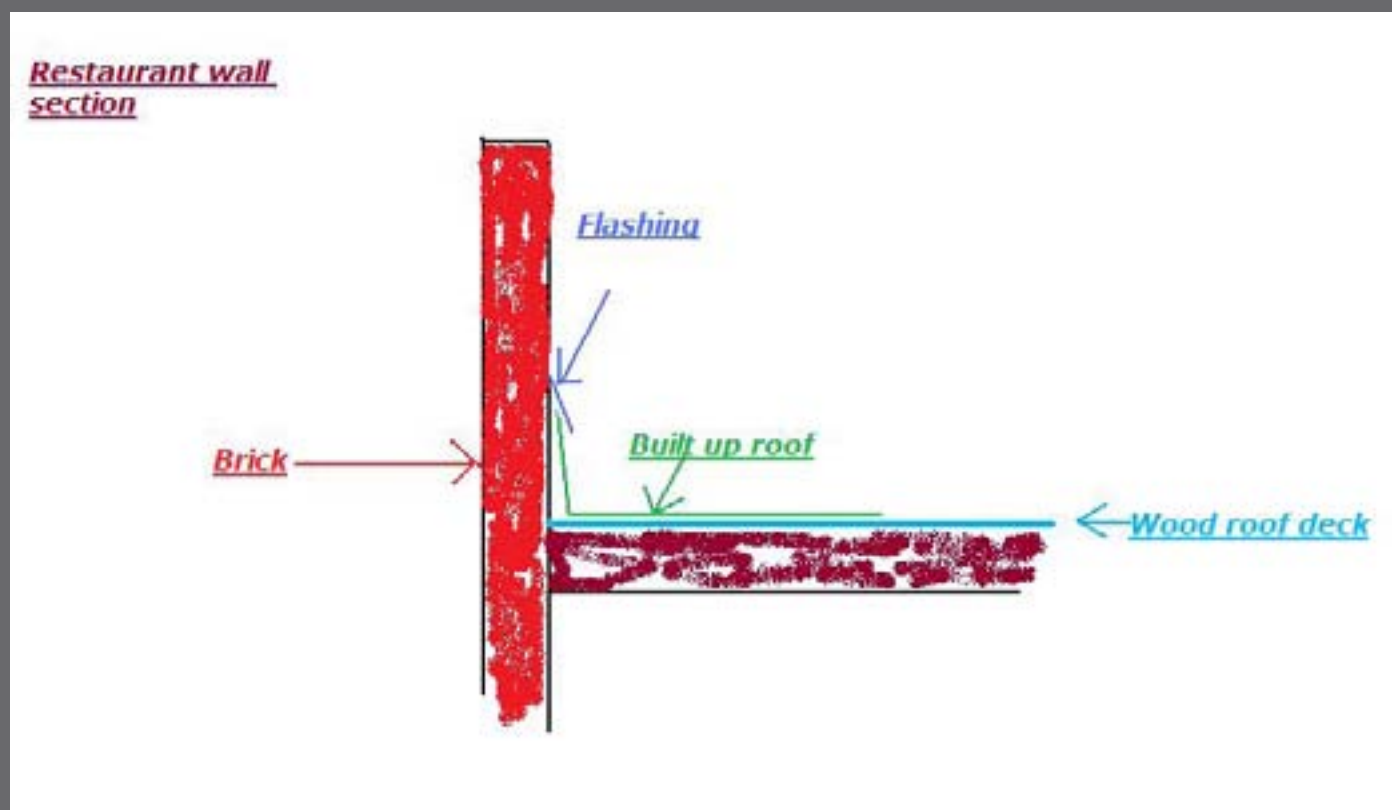

Figure 44: Drawing of flashing detail.

See (Figure 44) for details on installing the wall flashing.

Cut the masking tape into 3' wide pieces that are as long as the wall sections. The masking tape is bent into a 90 degree length-wise and is applied to the joint between the roof deck and the wall section. The masking tape should go up the wall about 12" to 18". The joint where the two inside corners come together should be overlapped. Paint the tape Polly Scale Grimy Black. Install the pre-painted-flat-aluminum .010 x .080 styrene strip on top of the masking tape that is attached to the wall (see Figure 44). This will represent the flashing protecting the joint between the wall and roof covering. Paint the masking tape grimy black (Figure 45).

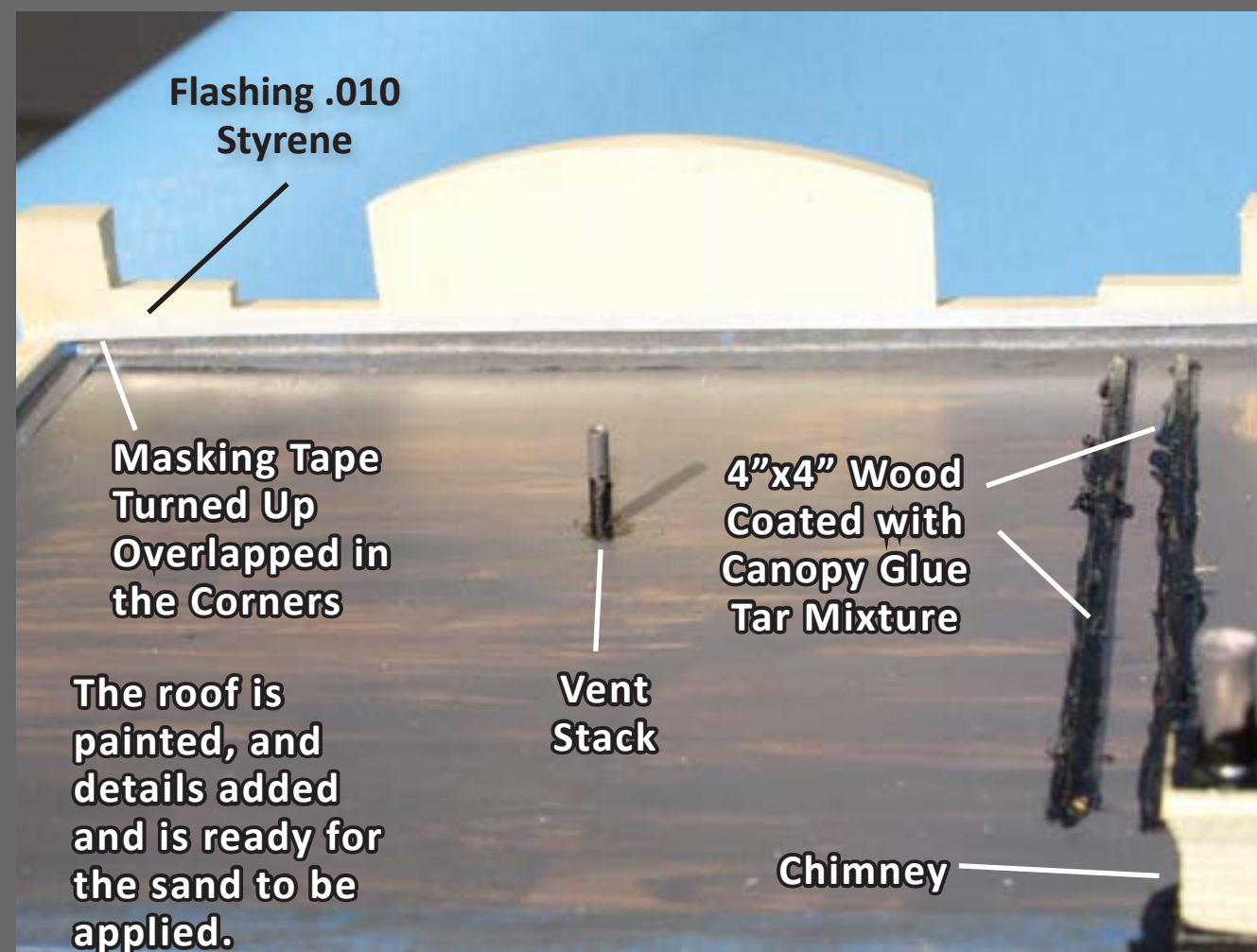

Figure 45: I've installed the flashing, pitch pockets, vent stack and chimney.

## STEP 4: Beck's Rook Station Cafe – More Flashing



Figure 46: Prototype picture of straight wall section with flashing installed.



Figure 47: Prototype picture showing step flashing installed. Notice that the tar from the built up roof is not neat.

I spray-painted 1"x4" Evergreen styrene strips a flat aluminum color and applied the painted strips to the top of the masking tape with canopy glue. This represents the flashing that keeps the water out of your building (Figures 46 and 47).

## STEP 5: Beck's Rook Station Cafe – Pitch Pockets

I spray-painted a Grandt Line chimney the yellow wall color and installed a piece of brass tubing in the top of the chimney. I glued it in using my tar glue mixture and then glued the chimney to the roof.

I attached 4"x4" stripwood pitch pockets to the roof with the tar glue mixture. These pitch pockets support the air conditioners and the refrigeration units.

I next installed the pitch pockets for the refrigeration lines using small pieces of 252 Evergreen square tubing (.125). I figured out where the placement of the air conditioners would be and then installed the lines in the front corner of each air conditioner using the tar glue mixture.

Following this, I installed the vent stack for the plumbing. I drilled a hole to accept the 1/16" brass tube that I previously painted black. I glued the tubing into the hole using the tar glue mixture.

Finally, I installed the gravel. I spread white glue full strength covering the entire roof. I was careful to not go up the inside corners of the wall – I only want to do the flat areas of the roof. I also don't want any sand up on the wood pitch pockets or on the square tubing pitch pockets.

I used fine white sand I found at Michaels Craft Store, applied to the white glue using a fine sieve, and I let it dry.

If needed after the first application dries, I added more sand with white glue to the roof to cover any bare spots or gaps. I avoided any large blobs or piles of sand on the roof.

## STEP 6: Beck's Rook Station Cafe – Air Conditioner



Figure 48: I modified the swamp cooler to make it look more like an air conditioning condenser sitting on 4"x4" wood sleepers. The fan housing on the top now makes it look like a direct-expansion condenser instead of a swamp cooler. (Swamp coolers are used mainly in the southwest part of the US).

After the roof was totally dry, I installed the additional details.

I built up the air conditioners from the Walthers modular roof detail package.

I modified the swamp cooler air conditioner as it comes in the package to become a "DX split system condensing unit". To do this, I cut out the cooling fan from the large air conditioner in the package, sanded the cut end smooth and installed it to the top of the small swamp cooler. Air conditioners are normally painted beige or green.

You could also use an HO Precision Scale engine roof fan #3550 detail to do the same (Figure 48). I drilled a small hole into the front corner of the air conditioner to match up with the pitch pockets. I attached the air conditioner to the pitch pockets with canopy glue.

I took two small pieces of 26ga. copper wire and installed them between the air conditioner units and the pitch pocket as piping.



Figure 49: Typical installations showing the "dog house" where the piping comes out of the roof and goes on roof supports to the condensing units.

I left one of the pieces of wire bare, and left the insulation left on the other. I painted the one with the insulation grimy black to represent pipe insulation.

A prototype picture of refrigeration piping is shown in Figure 49.



## STEP 7: Beck's Rook Station Cafe – Other

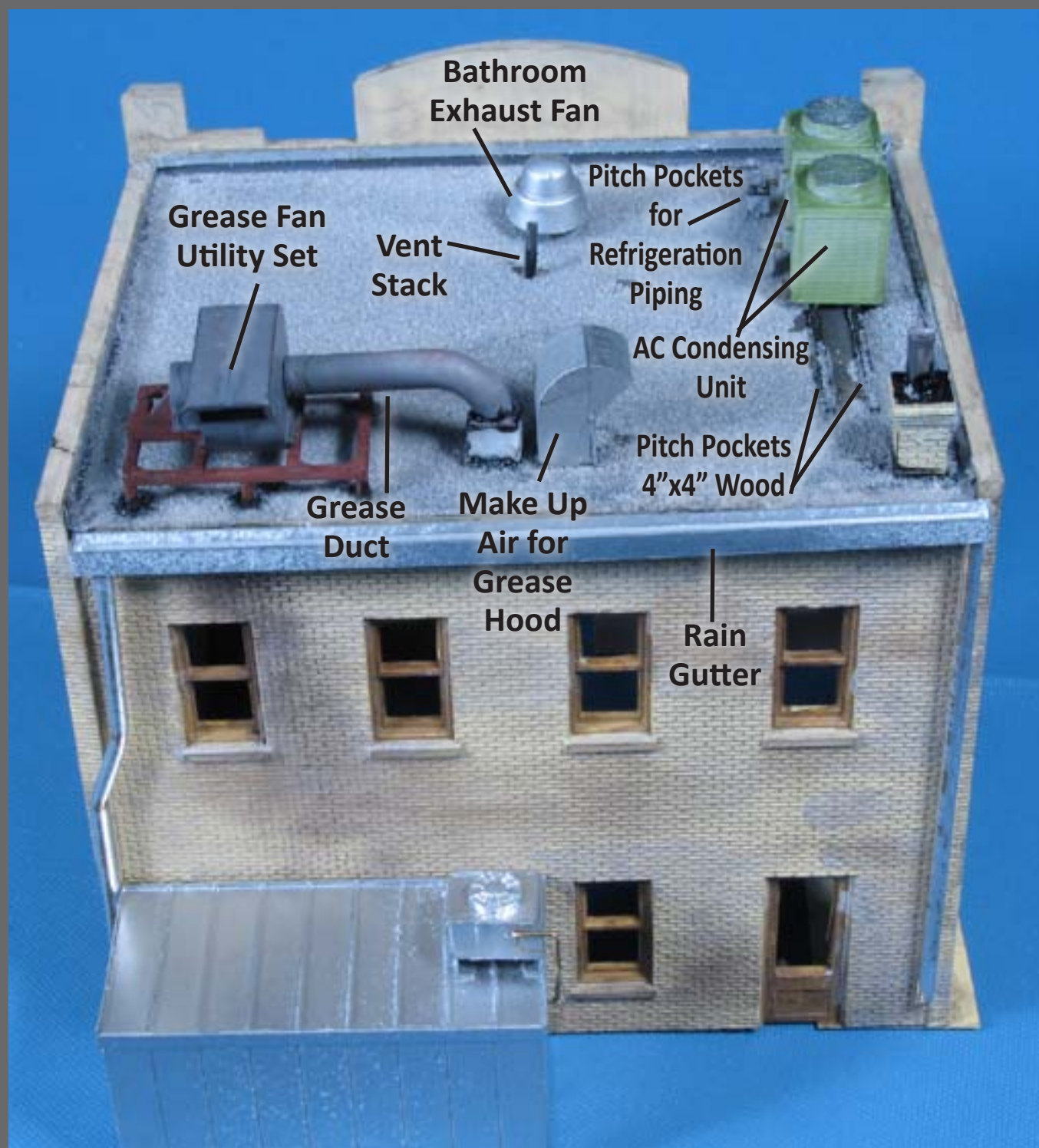

Figure 50: Grease exhaust fan, makeup air ductwork, condensers, bathroom exhaust fan, gutters and down spouts and the finished roofing gravel.

I used the roof blower as it comes in the Walthers package as a grease exhaust fan. I built up a curb using square styrene tubing. I reamed the square end with Xacto knife to accept the round end of the pipe.

I built the exhaust fan stock and made no modifications to it.

I installed the angled makeup air intake next to the grease exhaust duct going down to the roof. See the sketch on step 1 for placement on the roof. I used the tar glue mixture to anchor them both down to the roof.

The motorized vent fan is the exhaust fan from the restrooms. I located this near the vent stack and installed it with the tar glue mixture.

I made a rain gutter from a piece of H beam and placed it at the roof edge. I formed a cap made of .10 styrene and glued it to the ends. I spray-painted this assembly a flat aluminum color and glued it in place.

I added a small amount of the sand up to the gutter edge.

I allowed the roof to dry a full day.

Finally I brushed a black shoe dye and alcohol mixture on the sand roof to bring out the texture (see sidebar). I ended up applying 3 coats of India ink mixture to the roof to get the look I wanted (Figure 50).

### ALCOHOL WEATHERING SOLUTION:

I mix 1/8 of a teaspoon of black shoe dye (not polish) into one quart of 70% alcohol. I use this solution for most of my basic weather stains. If it is too dark, add more alcohol. When you do wood, it will come out as a nice old barn gray. Try it on some scrap wood first. Some shoe dye is very strong, so go easy at first, and then add as needed. ■

## STEP 8: Beck's Rook Station Cafe – Compressor

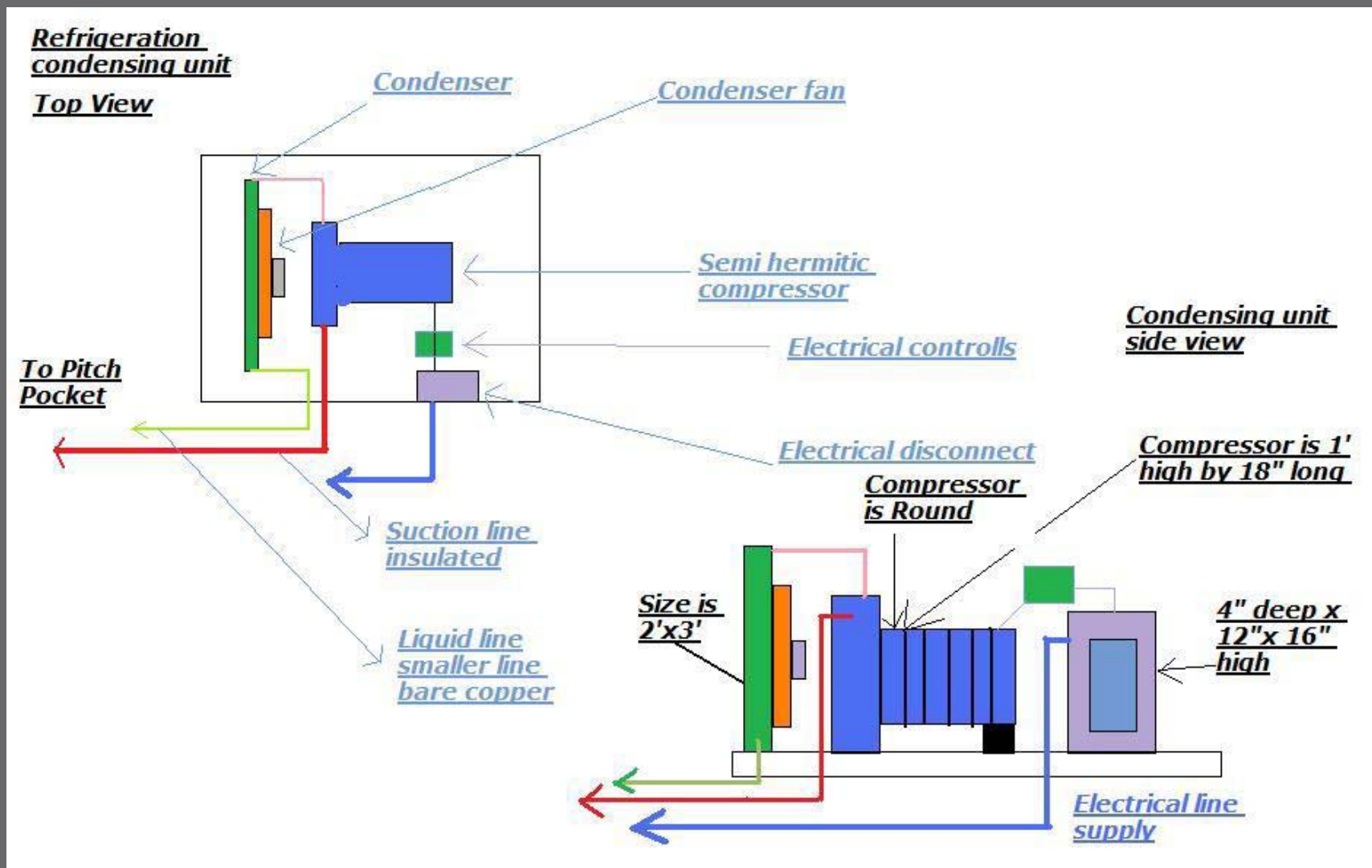

Figure 51: Layout of refrigeration condenser unit. Also see Figure 18 for the prototype inspiration for this unit.

I constructed a refrigeration compressor unit from 234 round Evergreen tubing on a piece of .060 styrene. See drawing above for more information. I ran the refrigeration lines from the pitch pocket over to the refrigeration unit using 22 ga. wire with the insulation left on (called the "suction line"). I used 22 ga. wire with the insulation striped bare for the "liquid line".

I spray-painted the compressor and condenser black, then dry brushed it Grimy black (Figure 52).

Figure 51 is a layout of the refrigeration condensing unit.

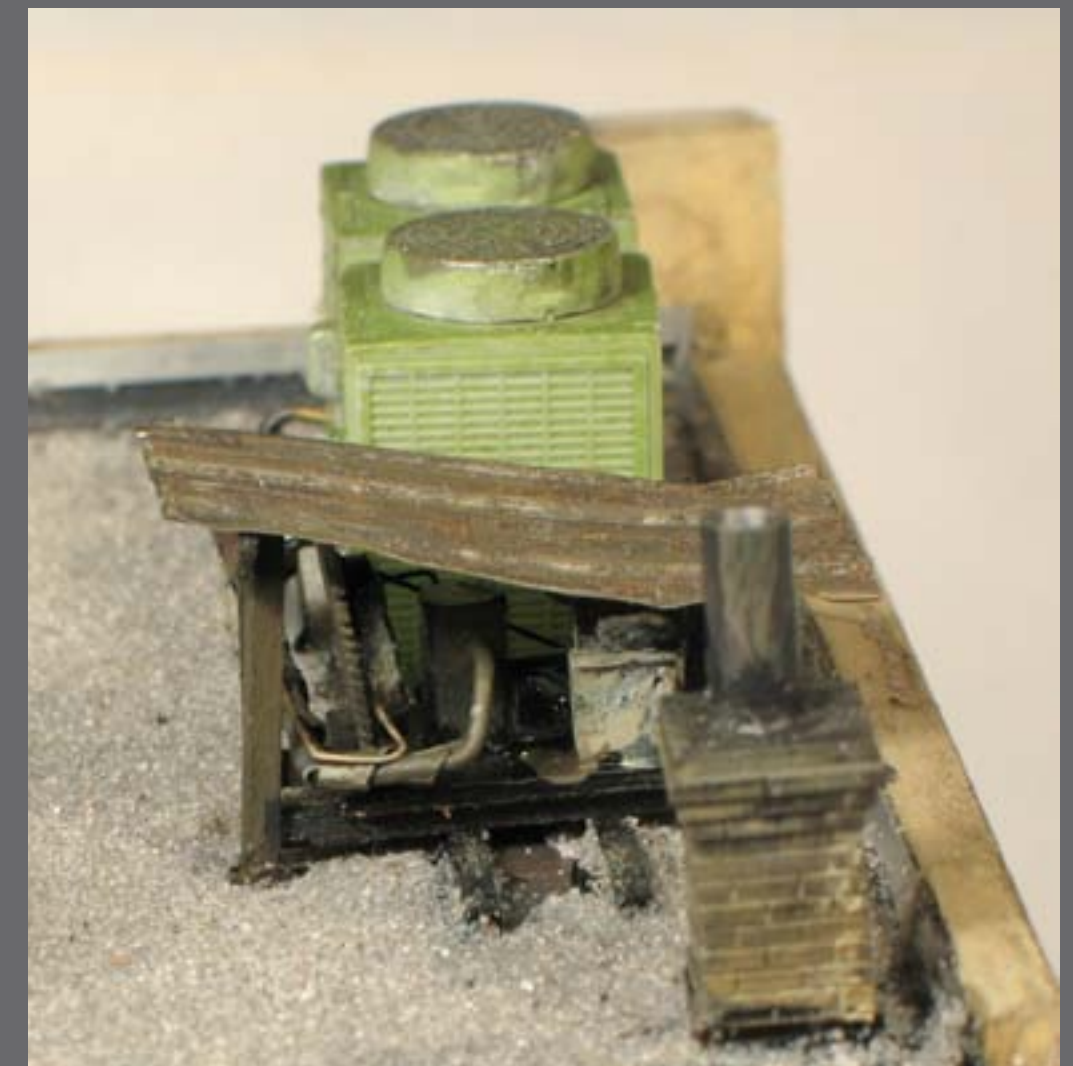

Figure 52: Refrigeration unit installed on the pitch pockets.

## STEP 9: Beck's Rook Station Cafe – Piping



Figure 53: Refrigeration piping connected to the condensing units.

I built the cover over the refrigeration unit from wood 4"x4" with some 2"x4" built to look like a "thrown-together roof". I used a piece of corrugated metal to cover it. (Figure 53)

## STEP 10: Beck's Rook Station Cafe – Roof Ladder



**Figure 54:** I installed a roof ladder on the side of the building.

I added a roof ladder to my building. This came from a Central Valley detail package (Figure 54).

## STEP 11: Beck's Rook Station Cafe – Weathering



**Figure 55:** Completed roof with weathering applied. Restaurant roofs are dirty and greasy, so weather it up!

I went back over the details with Grimy black to tone down anything that was too bright (Figure 55).

## STEP 12: Beck's Rook Station Cafe – Roof Types

The two buildings that I just covered are in a block of four stores on my layout. Here are the other two roof tops. (Figures 56 and 57)

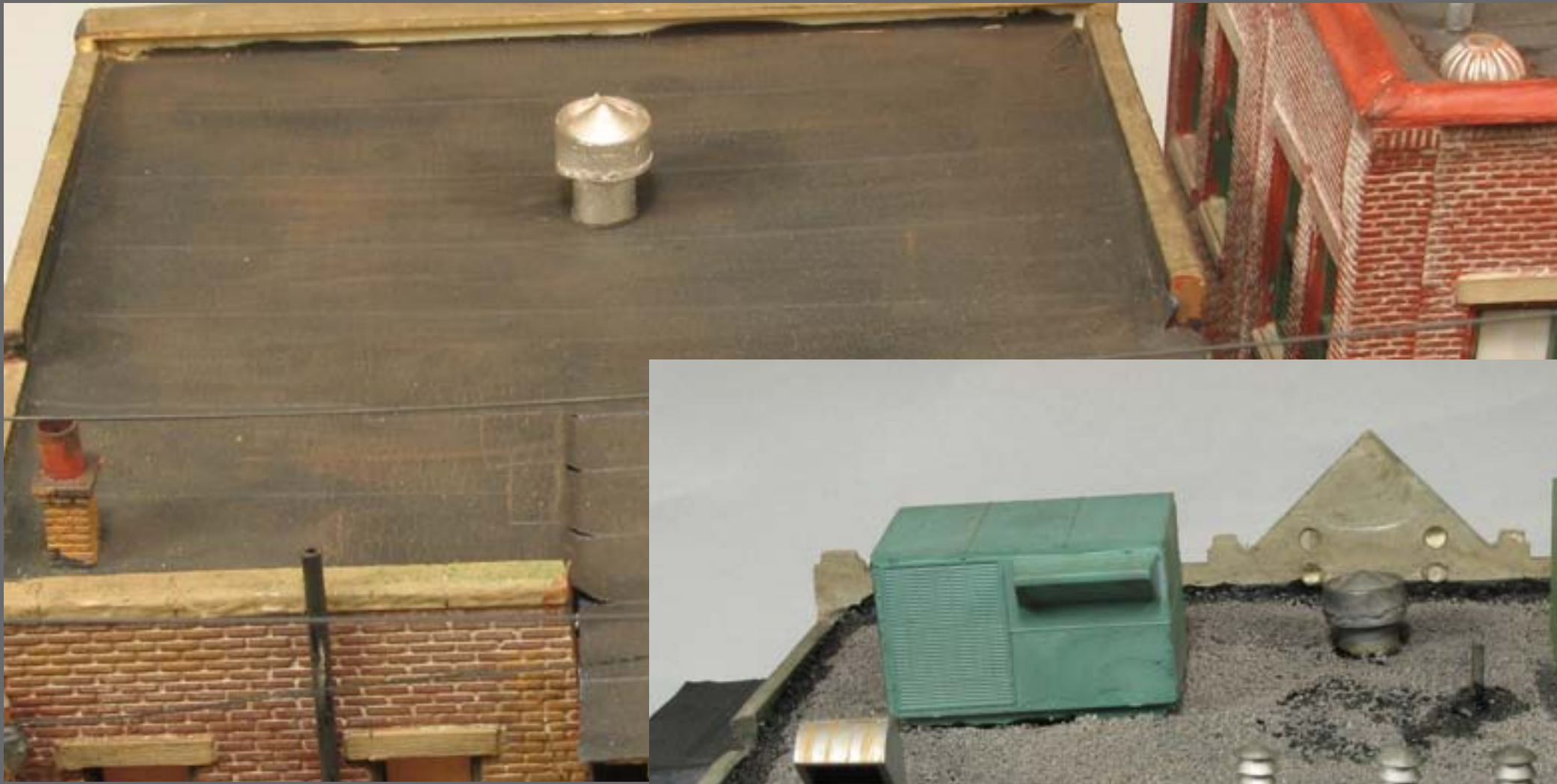

Figure 56: This building has a business on first floor with a residence above. This roof is very basic with just a single roof ventilator.



Figure 57: This is a store with additional air conditioner package units installed. The roof on this building has been leaking and I've added tar to show they've been trying to stop the leak. I've mounted roof scuppers on the back of the building.

## STEP 12: Beck's Rook Station Cafe – Roof Types



Figure 58: Typical main street blocks of stores that were built in the 1920s and modified to meet today's standards. The different roof heights, materials, and equipment makes it very appealing to try to model this – instead of just having nothing much on your roofs.



Figure 59: Notice the different roofing types and different elevations of the buildings.



(Figures 58, 59, 60) These pictures show some prototypical roof tops in a block of stores that were built in the 1920s. Some of the roofs layouts are original and some have been modified.

Figure 60:  
Trees will grow  
anywhere!

Items used to construct the details for the models:

- Plastruct HO Spanish Tile ps 122
- Walthers roof top modulars 933-3733
- Michaels Art and Crafts Deco Sand
- Great Western Models DP 108
- Campbell Scale Models Skylights 200-909
- Grandt Line chimney 5057
- Precision Scale Engine roof fan 3550
- Central Valley Model Works 1602 Steps and ladders

I hope you've learned a few tips on how to make your model rooftops more interesting and realistic!



### Tom Wilson

Tom has been a Model Railroader for 37 years, and now has a 4-level operating layout. He lives in Florida with his wife of 35 years, and works as a Building inspector.

In addition, Tom has worked in steel mills, and done mechanical contracting. As a building inspector, he has worked for Disney and now for the City of Winter Park, Florida.

Tom's website is:  
[www.pwvrr.webs.com](http://www.pwvrr.webs.com).

# Ah Ha! The Search is over!



Click to learn more

- DCC circuit breakers
  - Blast-mode programming booster
  - Wabbit turnout control
- ... and other *hard-to-find* DCC goodies



# BRINGING YOUR LAYOUT ALIVE

Done correctly, a properly positioned detail can provide the illusion of movement to any static scene.

– by *Bob Grech*  
Photos by the author



Figure 1: Posing these painters in the act of performing work provides an illusion of movement.

 **Reader Feedback**   
(click here)

One of the most enjoyable aspects of model railroading is animation. The realistic movement of trains through scenic vistas allows us to believe our trains are actually going somewhere. However, when adding motionless people or other static details to the scene, this illusion is often lost.



## Modeling Tips for Figures and Vehicles

Creating the illusion of movement to an otherwise frozen object can be a real modeling challenge. As a result, some modelers avoid the use of miniature figures or vehicles altogether. Done correctly, a properly positioned detail can provide the illusion of movement to any static scene. So how does one accomplish this feat? There are many schools of thought on this. One method that has worked for me

is by positioning my figures as if to tell a story. I do this by posing my “little people” going about their daily lives.

Fortunately, today’s modeler has a wide variety of figures to choose from, many of which come pre-positioned in almost every conceivable way. However, don’t be afraid to “chop off” and reposition the arms and legs of figures in order to achieve a pose you’re after.

When adding vehicles to your scene, remember that in the “real world”



Figure 2: In this next example, the illusion of movement is achieved by having these workers caught in the act of replacing a billboard. Also, note how the front tires on the foreground vehicle were rotated to suggest it’s making a left hand turn.



Figure 3: Gloss medium and acrylic paints were used to create the frothy bow waves and wake around this Tug Boat.

most are usually in motion. To recreate this illusion, here are a few tips I follow:

- Add drivers and passengers to those “on-the-road” vehicles.
- Swivel the front tires left or right to indicate a vehicle entering a turn.
- Position vehicles at slight angles to simulate the turning motion.

### Waterfront Detailing Tips

Many model railroaders include a waterfront to their layout. However, some fall short when it comes to creating a believable scene. Those who have been in our hobby long enough

can tell you the importance of adding ripples and waves to a water scene. But how does one create the illusion of movement when adding boats or other details? Here are a few ideas you may want to try.

– To make my boats look like they’re in motion, I use gloss medium to build bow waves and wake. Painting the gloss medium with acrylic white paint will create a realistic breakwater effect.

– When creating wake effects, I like to introduce air bubbles into the medium in order to simulate turbulent water.

Swimmers, ducks, and other details also leave behind wakes whenever

they move across the water surface. Create these wakes using gloss medium and acrylic paints as before. If you do decide to add swimmers or other details to your water, try cutting them down first. This will make them look truly submerged.

## Putting It All Together

We live in a world of motion. Keep this in mind when building your next layout. While it's acceptable to model people at rest, creating a sense of motion can help make static scenes more dynamic. Hopefully these tips

have sparked your imagination. So why not give these ideas a try on your layout. 



**When you see  
this symbol,  
it means:**

***“Click here to  
learn more!”***

***Every click tells  
advertisers an ad in MRH  
is a wise investment ...***



Figure 4: Gloss medium and white acrylic paint was used to make the figure appear to be moving across the surface.



Figure 5: Careful placement of people and cars can add the missing element of motion.



Bob's interest in model trains spans over 40 years. His Western Pacific layout was featured in the November 2006 issue of Model Railroader, and also in How To Build Realistic Layouts vol 4.

Bob lives in Fountain Valley Ca, and is employed as a Mechanical Engineer for the Boeing Company.



**Reader  
Feedback**  
*(click here)*



# Craig Bisgeier's

## THE Housatonic Rail Road Company



Grab your rail pass and ride along on Craig Bisgeier's model of the Housatonic Railroad Company set in 1892. This railroad ran through Connecticut next to the

Housatonic river in a battle to the death with the New Haven. Modeling this era is not easy, as there is very little in the way of appropriate structures or

rolling stock readily available, but Craig and his crew are not afraid to find and use creative alternatives. Take a look at his results so far!

**M**odel Railroad Hobbyist had the opportunity to visit Craig's Housatonic layout during the July 2009 National Train Convention where Craig graciously allowed Les Halmos to interview him.

Interview by Les Halmos, photos by Joe Fugate (except where noted), video by Charlie Comstock.



## Wilson Point

**Les:** Craig, Wilson Point was an important part of the Housatonic Railroad. Would you give us a little insight on what's here?

**Craig:** This is the south end of the railroad. In 1892 the Housatonic was in serious competition with the New Haven railroad, which at that time controlled all of the preferred routes into New York City, keeping the rest of the railroads from New England out.

The Housatonic took over a smaller railroad, the Danbury and Norwalk, in 1887 giving them access to a port on Long Island Sound closer to New York City. They ran their New York traffic down to Wilson Point, where they built a very large rail-marine terminal, loaded the freight on ships and got it to New York that way. They also shipped to other locations from Baltimore to

Boston. They'd regularly put cars on car floats and send them to places like Brooklyn, Long Island or New Jersey. Other times they'd load the cargo into steamships (and vice-versa).

There were also bulk commodities, such as coal and lumber arriving at Wilson Point. A large jib crane, run by a steam engine was used to unload coal and lumber [from ships and barges] onto the railroad supplying fuel and other materials to communities up and down the line.

**Les:** You've built an amazing model of the huge wharf at Wilson Point. How much wood do you have in there?

**Craig:** Well, thousands of pilings made from  $\frac{1}{8}$ " dowels to be sure. The rest it's hard to say. I cut up a large piece of basswood on my table saw to make the decking and beams, there's prob-



Figure 4



Figure 2



Figure 3

FIGURE 1 (previous page): A good look at some of the Housatonic motive power while it waits to head north at Wilson Point.

FIGURE 2: The Wilson Point engine facility. Although much of the Wilson Point facility was built on a wharf, this area is on solid ground.

FIGURE 3: The warehouse on the wharf at Wilson Point

FIGURE 4: An overview of the HUGE wharf at Wilson Point. It contains over 2400 pilings and took about 5 months to build.



Figure 5



Figure 6



Figure 7

ably well over 1,000 feet of stripwood in there. The entire pier had to be built before we could lay any track and that took about 5 months. I had a ton of help - my friend **David Ramos** installed all the pilings - and he still talks to me. The deck planks of the pier are laid on  $\frac{1}{8}$ " plywood which lies on the cap timbers which sit on the pilings.

**Les:** How about the water, how did you do that? Were there any problems?

**Craig:** Well we did have some issues with it. We put all the pilings in and painted the water bed a nice blue color in order to make it look like deep water here. One weekend, a number of my operators came by and we had a big party to pour all the water. Through some unfortunate miscommunication, the Enviro-Tex which is the epoxy that we used to represent water was mixed much too vigorously and ended up like meringue - a foamy mess. We were all

panicking but we decided to pour it out and spread it, hoping everything would be OK. It looked a lot like a wedding cake! We were sure it was going to be a disaster until one of my guys remembered, "Hey wait a minute! Aren't we supposed to go over it with a propane torch to get the bubbles to release?" So I ran and got my plumbing torch. We weaved it across the foam, and just like that, the bubbles collapsed and the epoxy was clear again. [Ed: *Enviro-Tex is a two part epoxy and the directions do say to mix the two parts together vigorously as under-mixing may cause it to not harden. The carbon dioxide from the torch reduces the surface tension, allowing bubbles to escape/pop*]

The other problem we had was that once the Enviro-Tex had cured, it was like a large mirror, you could see reflections of the ceiling lights! So we went back over it with a combination of gel

and liquid gloss medium, stippling it on with paint brushes to get the wavy texture in the water. I'm very happy with the way it finally came out.

**Les:** Well it looks great to us. We're amazed at the size of this thing. How big is Wilson Point anyway?

**Craig:** The pier is about 14' long and 3' wide at its widest point. The plans were very difficult to come by. We eventually did find them on a 1888 Coast Guard nautical map - which was the only map we could find that showed how all this was laid out. It existed from about 1887 to 1897 so it was only there for a short period of time.

**Joe:** I cannot imagine myself having the patience to do all the strip wood that went into this wharf. You must have used a whole basswood tree or something.

**Craig:** Pretty much! And there's a story about this thing. Underneath every-

**FIGURE 5:** The ash pit, coaling bucket, turntable and roundhouse as Wilson Point.

**FIGURE 6:** Two engines ready to go. In 1892 locos were much smaller than transition era.

**FIGURE 7:** The clamshell used to unload bulk coal from barges into gondola cars.

thing you see here is plywood and homasote except for the water which is plywood about an  $1\frac{1}{2}$ " below the ground level.

When we built the pier we used  $\frac{1}{8}$ " dowels for the pilings. We made up a jig to drill the holes and spent about a month doing that - it takes a while to drill 2,400 holes!

We stained the dowels first, then glued them in the holes. To get them all the same height we made a jig which we used with a cut-off saw (a flush cutting saw with very little kerf). We'd put the



Figure 8

FIGURE 8: Cutting the piles to length using a flush cutting saw and jig. Craig Bisgeier photo.

FIGURE 9: Home-made strip wood for the wharf at Wilson Point. Craig Bisgeier photo.



Figure 9

jig over each piling, and holding the saw down on the jig cut the piling to the correct height (figure 8). It took a long time to put all the pilings in - days and days and days... I've got to thank very much my friends **Dave Ramos** and **Neil Henning** and a couple of the other guys because they really put in a ton of work on this.

Once all the pilings were in, we set  $\frac{1}{8}$ " x  $\frac{1}{8}$ " basswood pile caps across each set and added diagonal bracing underneath to match our prototype (figure 3). When

that was done we covered everything with  $\frac{1}{8}$ " model aircraft plywood so the entire thing has a great deal of strength, which is needed. Then came the strip wood decking.

For a while making stripwood was a full-time job. I'd work several nights to get a supply of decking ready for work night. I'd get it cut and sanded to about  $\frac{3}{16}$ " x  $\frac{1}{16}$ ", then I'd paint it and stain it to get it to look right, and finally cut it to length. By the next work session I'd have a pile about the size of a large shoebox. On work night, three guys would sit down and they'd go crazy for 3 hours gluing it in place, and they'd run through the entire supply (see figure 9). The next night, I'd have to start cutting all over again. That went on for about 6 weeks!

I think this whole pier took 5 months to build and we didn't actually put a single rail down on any of this until about 8 or 9 months into the project. It was a ton of work and I gotta tell you the guys who worked on it were just great - they were so excited about it.

**Les:** How did you get the roundhouse?

**Craig:** The roundhouse came from a photograph that we found in the book, *"In the Shoreline's Shadow"* by L.P. Cornwall, which was the inspiration for a good part of the railroad. It's very similar to another roundhouse that the New Haven had in Pittsfield, Massachusetts. As far as I know there's only one actual photo of this roundhouse in existence and that's the one we had. It was a very small photo in the book, but from it we were able to see pretty much everything that we needed to create CAD drawings.



Based on the size of the locomotives, we figured out how large the doors were and from that we were able to scale the entire model. I created drawings and **Neil Henning** made styrene masters from them for the parts in the roundhouse. We used the masters to create rubber molds and made resin castings of the parts. **Ray Lewis** did most of the assembly but I did the trusses on the inside to support the roof. The first attempt at the roof didn't work out well, so **Neil** made a second attempt and that's what you see here now. The doors on the roundhouse are homemade castings as well.

This was a completely scratchbuilt project. Using masters to make molds, then casting multiple copies of the parts made it easier. It's a close match to size of the actual roundhouse, though we did find out after getting plans for the Pittsfield roundhouse that it's 10' shorter than the real one.

FIGURE 10: Scratch built structures in South Norwalk. The brick buildings were made using custom resin castings from home-made masters and molds.

**Les:** It looks good to me! How about the turntable?

**Craig:** The turntable is a 55' Diamond Scale model kit (figures 2 & 5). It worked out just about perfectly for us - a Bachmann 4-6-0 fits great on it. It wasn't too difficult to build, but it did get challenging in places. It works very nicely; we haven't had any trouble with it at all.

We scratchbuilt the ash pit next to it. This is just a ramp with track that goes down. They'd spot a gondola down there and use shovels to load the ashes into it.

The structure next to it will eventually be replaced. It was based on a model that I think Durango Press made. The bucket would be loaded with coal by



**FIGURE 11: South Norwalk just north of Wilson Point (on the lower deck). Wilson point is across the aisle to the right from here. Note Dock Yard on the far left against the backdrop.**

hand and the winch would raise it to tender level. A very manual operation.

## South Norwalk

**Les:** Following the track north out of Wilson Point there's another town. What's significant about it?

**Craig:** This is South Norwalk, Connecticut (figures 10 & 11) which is a couple of miles north of Wilson Point. The railroad's primary yard on the southern end, Dock Yard, was located here because there wasn't enough space at Wilson Point for a classification yard.

After cars came off a float at Wilson Point (or before they went to a float), they'd go through the yard at South Norwalk for sorting.

There are 4 tracks in the back (see figure 11) plus several team tracks and a large freight house here. The team tracks were important in this era because most industries didn't have their own sidings. The consignees who were getting their freight would come here with a cart or a wagon [and a team of horses], off-load their stuff into the cart, then take it away.

A lot of the structures you see here are based on the prototype buildings of this town. For instance, the Housatonic's freight house I mentioned a moment ago is based on a number of

photographs I obtained from a friend who lived in Connecticut. He shot them just before it was torn down.

The Norwalk Iron Works is another prototype based building. Like the roundhouse, we made this large brick structure from resin parts cast in home-made molds. We made a styrene master, made rubber molds from that and cast multiple copies to build it. The prototype is still in existence today.

**Les:** Is that right?

**Craig:** Yes, it's actually part of the Norwalk Aquarium. It's really wonderful that you can see it today.

Hatch Bailey & Co. is a company that existed here, but this building is imagined because we don't know what it looked like. We have the Sanborn maps that show us this building existed and where everything was but no photos. It's kitbashed from DPM parts for a nice New England look.

**Les:** I see you have signage on the buildings. How did you do that?

**Craig:** I'm very fortunate to have an ALPS printer with the capability of printing in white ink and that's really useful for making decals with white lettering (figure 12). A lot of the custom freight cars on the railroad have lettering done the same way.

We originally built South Norwalk with only the mainline and one passing siding even though we knew from some 1915 valuation maps that there was more than one passing track present. But we thought, OK, no big deal,



**FIGURE 12: An example of the custom decals produced with an ALPS printer.**

it should be enough. We found out after the first two operating sessions that we were wrong! It really needed a second passing track, so about a year and a half after we finished building this area, we came back and put in a second one. Since then operation has been much smoother.

## Fusees

**Les:** You operate under time table and train order rules and you have a unique way of implementing one of those rules?

**Craig:** We do operate Time Table and Train Order here on the Housatonic. One of the things I've always wanted to implement is the part of rule 99, which states that if your train is moving slowly and might be overtaken by a following train the conductor should drop a lit fusee [similar to a highway flare] on the track at 10 minute intervals.

The fusees burn for 10 minutes and if another train finds a lit fusee, they're supposed to stop, wait for it to go out, and then proceed at restricted speed until they either meet the obstructing train or reach the next town. The idea

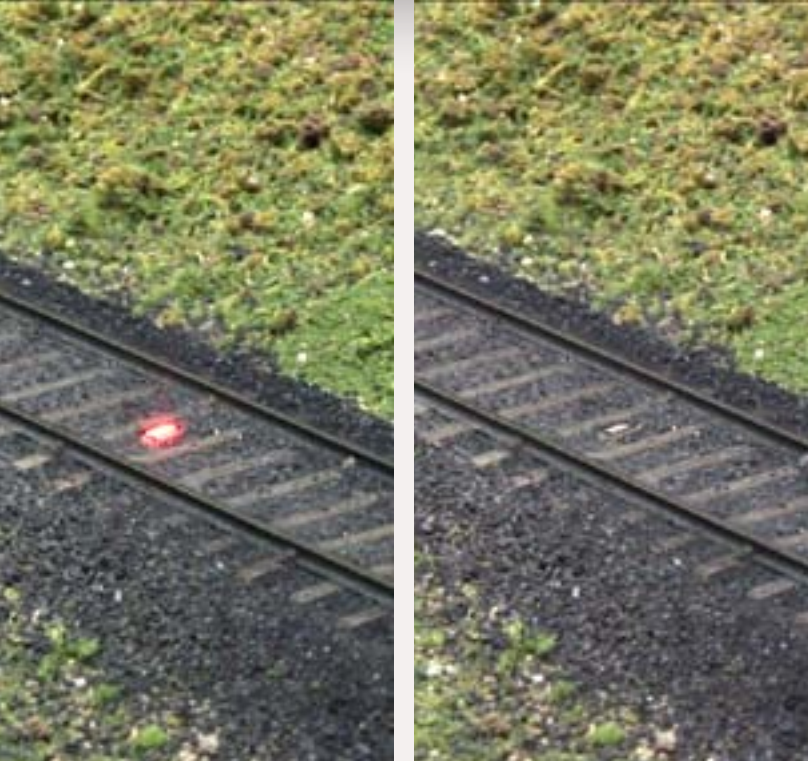

**FIGURE 13 a,b:** The fusee at South Norwalk lit and extinguished. The between-the-rails LED is electronically controlled to ‘burn’ for 10 scale minutes once activated.

was to maintain a ten minute separation between trains when there were no radios.

I’ve found that rule to be fascinating and wanted to model it but wasn’t sure how. I talked with a gentleman named **Joe Smith** about my needs and he came up with an electronic circuit. When the conductor hits a fascia switch [drops a fusee] a bright red LED embedded in the track lights up. It stays lit for 10 fast minutes and then goes out (figures 13a & 13b).

If you’re on a train that’s running late, each time you pass one of these ‘fusee locations’ you would flip the switch to light the LED. In 10 scale minutes (3 minutes and 20 seconds on this railroad) that LED will go out. If another train comes to the lit LED, they must obey rule 99 by stopping and waiting for it to go out before proceeding.

## Scenery

**Les:** What about scenery?

**Craig:** There’s a little scenery started as a test, more than anything, out toward the end of the peninsula (figure 14). Scenery, up to this point hasn’t really been my forte and there’s not a lot of it – I do have a couple guys in my crew who are good at it, **Scott Dunlap**, for one. They did most of the work over in South Norwalk that you’ve seen already.

I recently attended a *Modeling with the Masters Clinic* at the NER Syracuse show a while back. There was a lot about scenery and how to do it so when I got back I came in and said, “OK, let me see if I can do what I learned there!”

That’s what this section is – putting the rocks in place and getting ground cover over them. I’m pretty pleased with the way it worked out, although I still need to add a few trees. I like the way it’s coming along and probably a good portion of the rest of the railroad will have similar types of scenery.

**Les:** It looks great! I like your rock outcrops there.

**Craig:** Thanks. They also taught us how to color rocks using acrylic paints. You start off with dark gray primer, then dab on a few earthy colors and smear them around. It looks awful when you first do it, but you kind of mix them a little more and they kind of blend together. Then you go back and dry-brush some white highlights onto it, and it comes out looking really well.



**FIGURE 14:** Craig showing Les the latest scenery and explaining the benefits he gets from the Bellina Drop at the end of the peninsula. **INSET:** Rock outcroppings: Craig Bisgeier photo.

It’s amazing because when you start out you’re thinking it looks terrible and isn’t going to work, but it actually turns out pretty well.

## A Bellina Drop

**Les:** I see you have a Bellina Drop at the end of your peninsula.

**Craig:** Yes, it’s named for an old friend of mine [Jerry Bellina] who developed the idea. It’s the curved backdrop [with scenery on the inside] that runs around the *outside* of this turn back blob. It solved several issues:

- The curve radius here can be very tight, making the blob smaller. Because you can’t look at trains from the outside of the curve while

they’re in there, cosmetic radii are not needed. I’m using a 18” radius here which works quite well with my short 1890’s era equipment [an advantage of modeling an early era!]

- Trains go in here and kind of disappear, you have to walk around to the other side [of the peninsula to follow the train]. When it comes out on the other side it feels like there’s been some distance traveled. It’s like when you’re watching a scene in a movie - when there’s a wipe on the screen you understand that some time has passed.
- It also keeps you from being able to look down both sides of the pen-



insula while standing in the same spot, which makes it seem larger.

- Perhaps best of all, you don't have to figure out what to do with the end of the turn back blob anymore. You don't have to have a big curved trestle or some sort of crazy industry that the thing loops around.

It really solves a lot of problems - keeps the railroad looking very linear which I really like.

**Les:** How do you deal with building scenery inside the Bellina Drop?

**Craig:** That can definitely be an issue [access-wise]! The way I worked it is to make it very tight on the side coming out of South Norwalk. On the other side [Winnipauk], the scene is much deeper and easier to see into, so it requires more of a viewblock like hills and trees. The scenery on the back edge is very narrow – the track is only about 2 1/2" away from the wall [back-side of the Bellina drop] so the scenery has to be nearly flat, the trees almost need to be painted on the backdrop with a little bit of ground foam stuck to them and such. It's more suggestive than anything.

**Les:** What's on the other side of this turn back blob?

**Craig:** Let's look. The scene is much deeper over here on the Winnipauk side, making it easier to reach inside (figure 17a). The scene that will eventually go here includes a hill running down into a mill pond and a mill building (there were plenty of mills through this area).

The mill will use the same wall castings as the model of the Iron Works in South Norwalk. We'll just cut it down a bit. It's really great getting more use out of the molds that we made.

There will be trees all along the inside edge on this side to hide the sharpness of the [turnback] curve. When the track comes out through the trees here it will look like a regular gentle curve.

## Fast Clock and Train Order Signal Panels

**Les:** I see a number of control panels with a clock and what look like stylized semaphore arms. What are these used for?

**Craig:** When I have op sessions, we run under Time Table and Train Order [TTTO] rules. When you arrive in a town, Winnipauk in this case [railroad north of the South Norwalk area], there is a clock and the train order signals.

The clocks are synchronized through [Mike Dodd's analog clock controller](#) (which is available again by the way) and show the official railroad time.

Train order signals share the panels with the clocks. They're controlled by the dispatcher, if he has prepared [train] orders for you, you'll see the semaphore board for your travel direction dropped down from green and be a horizontal red bar indicating you need to get the train orders posted for your train before proceeding.

**Les:** Do you have problems getting crews to look at the signals?



FIGURE 15: One of the combination clock and train order semaphore panels Craig uses during op sessions.

FIGURE 16: Apparently size does matter. A MDC 36' truss rod car on the right, normally considered tiny, dwarfs the BTS Civil War era car to its left.



# The Housatonic Railroad, D&N Division, 1892

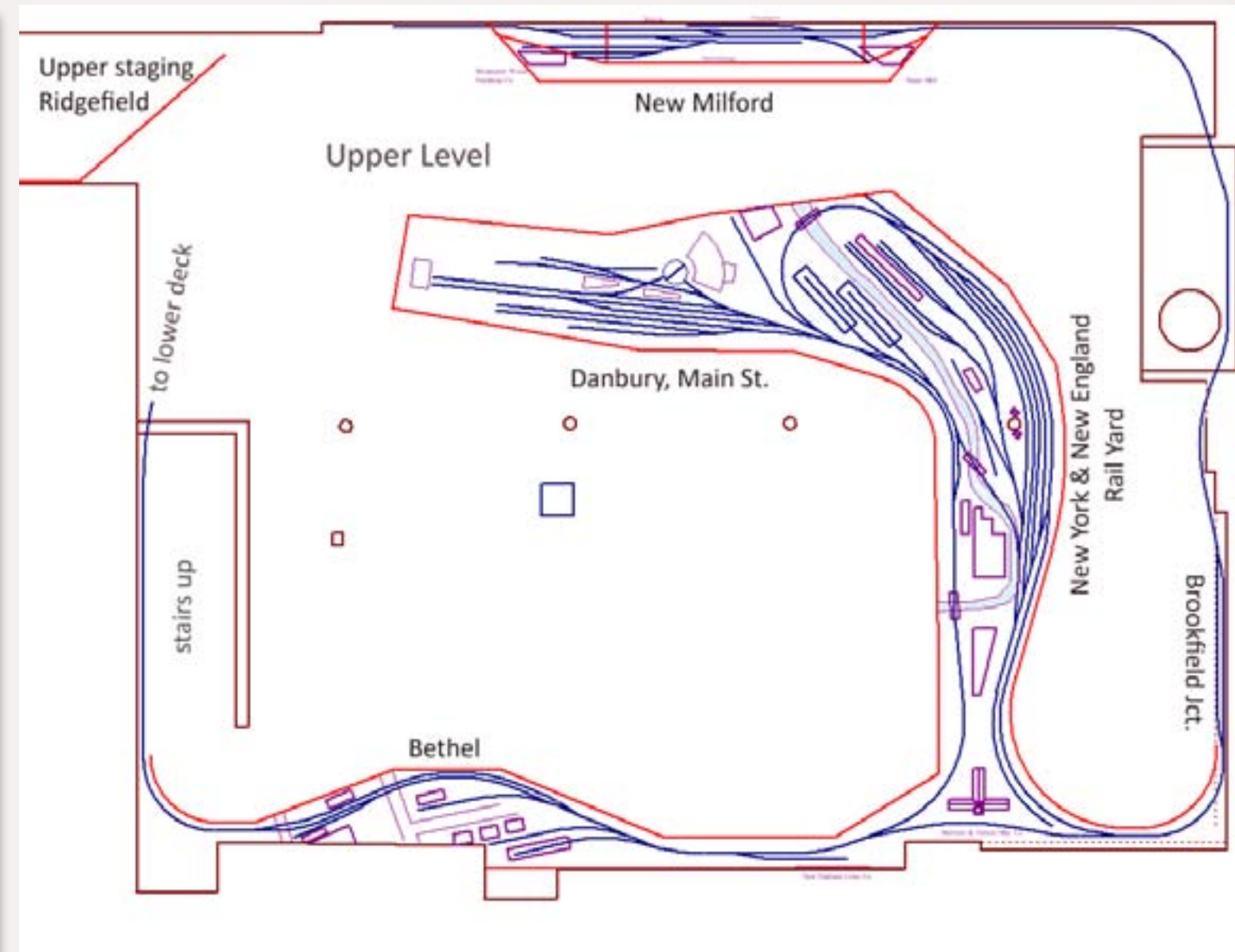
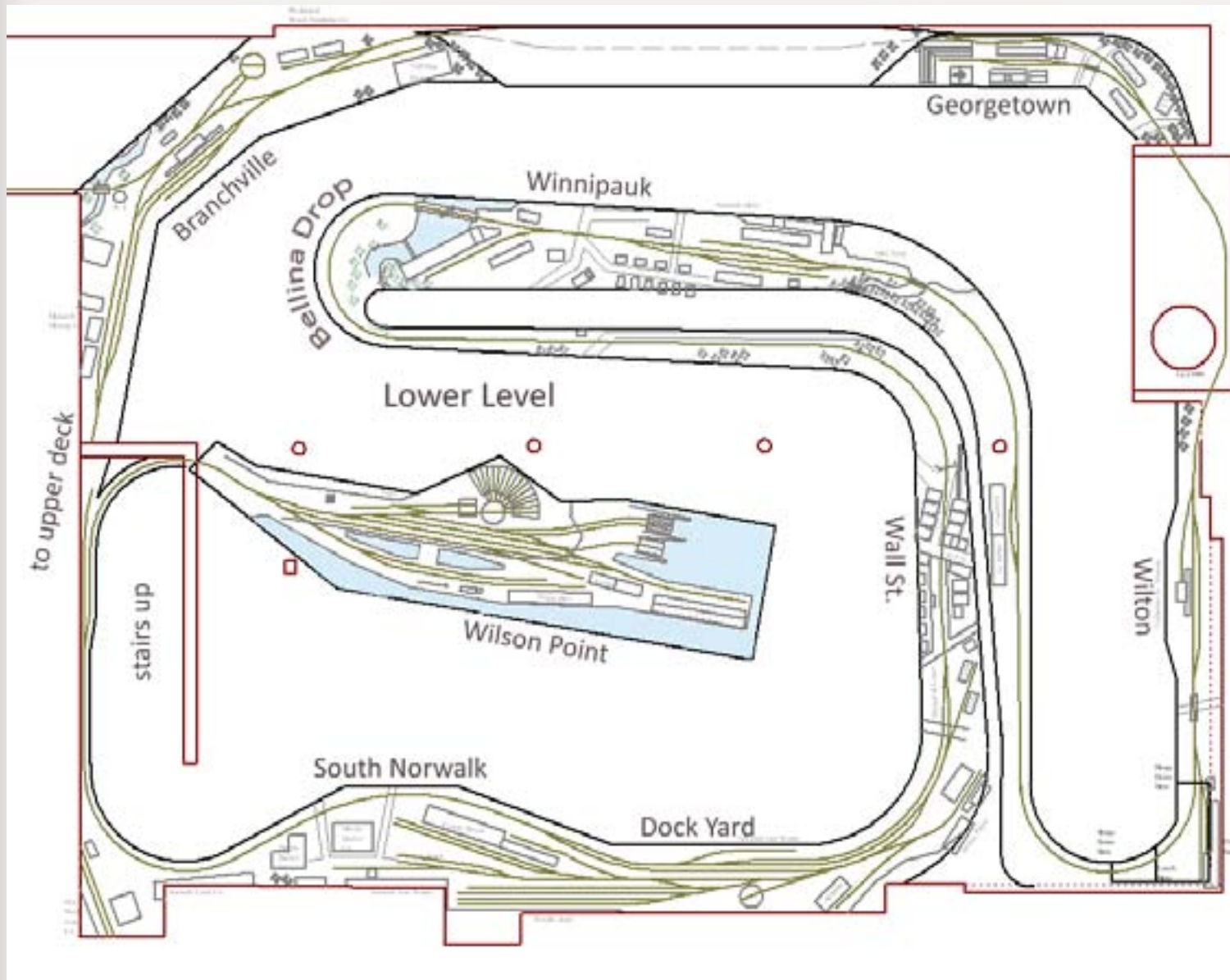

FIGURE 17 a,b: HO scale Housatonic Railroad track plans for the upper and lower decks.

## Layout Summary

**Name:** The 1892 Housatonic Railroad

**Locale:** Connecticut

**Era:** 1892

**Scale:** HO standard gauge

**Track style:** point to point, multi-deck, nolix

**Mainline length:** 300'

**Min turnout:** #5

**Min radius:** 18" mainline, 15" industrial

**Max grade:** 1.5%

**Turnout control:** manual switch stands and R/C servos

**Track elevation:** 46" to 60"

**Loco control:** DCC

**Dispatching:** Time Table & Train Order



**Craig:** We find [the dual mode] panels work very well because as the operators are coming through a town, they need to check their timetables against the time. Their eyes are drawn to clock/train order panel so they're very likely to see a train order signal set to stop.

### Rolling Stock

**Les:** Is it difficult to find rolling stock for an 1892 layout, Craig?

**Craig:** Part of the problem with modeling an early period is that there's very little equipment available. You have to be willing to put up with some compromises or do a lot of scratchbuilding!

For instance, this Northern Pacific car (on the right in figure 16), is a standard Model Die Casting 36', truss-rod box car that's been available for many years. A lot of people use them but for me, they're a little bit oversized. This size came into popular use around 1900 or 1905 which is later than my era. In 1892 fewer than 10% of the national fleet would have been this size.

I have some other cars built from BTS [Bills Train Shop] kits. These are civil war box cars dating from about 1865 or so (left in figure 16) and are a bit old for my railroad. Wooden cars lasted only 15 years or so. They had a very

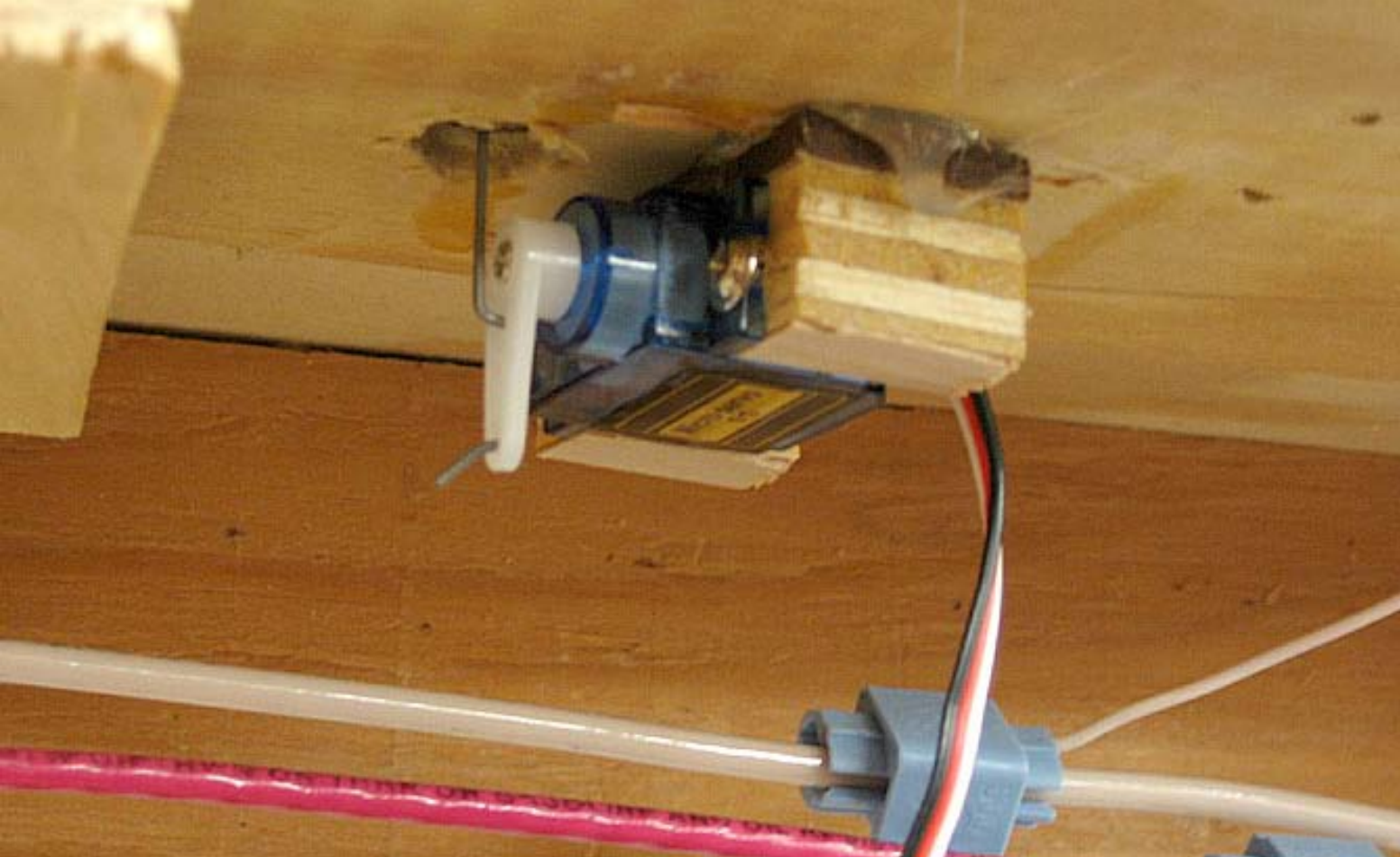

**FIGURE 18:** A small R/C model airplane servo sitting under a turnout on Craig's layout. Craig Bisgeier photo.

**FIGURE 20:** Mounting bracket for R/C servo. Craig Bisgeier photo.

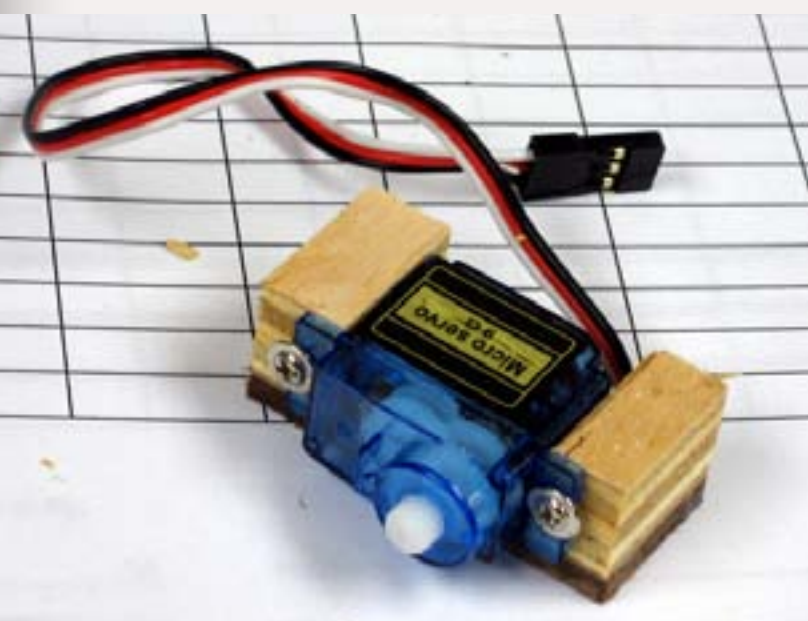

short life because they didn't carry much, and were badly abused [overloaded] more often than not. Plus car size and capacity changed rapidly, doubling from 1870 to 1900. I have many cars kitbashed from trainset cars and

other models that have a correct look and feel for the period.

I've been supplementing my car fleet with a number of resin cars that we built masters for and have been casting ourselves to increase the fleet of cars that are correct for 1892. As the number of period-correct cars increases we'll be removing some of the larger [MDC] box cars which really aren't appropriate.

The goal is to get a more realistic railroad with appropriate cars as we go forward. But for now, in order to operate, this is one of the compromises that we've had to make. Otherwise we simply wouldn't have enough cars.

## Servos and Turnouts

**Les:** I see a PC board here at Branchville, Craig. What's it for?

**Craig:** This is pretty exciting. A while back I met Duncan McRee through the

[Model RailCast Show](#) show. He had some really interesting ideas on ways to control turnouts using radio control model aircraft servos [see [Model Railroad Hobbyist - Issue #3](#)]. Normally they aren't used by model railroaders because it's not as simple as something like a Tortoise where you just run a couple of wires. Servos need power, but they also need a control signal that tells it how far to turn the crank. Duncan came up with a method to do this using a programmable chip.

The controller sets pre-programmed limits for how far to throw in each direction customized for each turnout - neither under-throwing nor overpowering it. It's all very easy.

It's exciting that when you add up the cost of the servo and the [control] board it's less expensive than Tortoises [and their wiring]. And I love the fact that the servos are so small, about the size of a Starburst candy. I was able to find a number of tiny servos on E-Bay from China. You can sometimes find them for under \$4 each. I ordered 100 because I knew I was going to need at least that many for this railroad. The controller boards cost on the order of \$30 and can run up to 8 servos.

We're planning to change all of the mechanical turnout controls over to servos because they work so well.

## Grades and Helpers

**Les:** Craig, I see your layout has multiple levels. Is there a helix somewhere?

**Craig:** No, Wilson Point has an elevation of 46" or so. Going north the tracks begin gaining elevation. It goes around the room until it hits about 56" at Branchville (end of the lower deck). The tracks make a second lap above the first and finally reaches 60" when it goes into staging.

So instead of having a helix to connect the two levels we actually have a gradual transition between the lower and upper levels as it goes around the room. The layout itself is a helix, this design style is called a nolix.

**Les:** What kind of grades do you have?

**Craig:** Usually not more than 1% but there's one place where it gets to 1.5%. We find that you can get a 4-4-0 or 4-6-0 to pull a train of 10 to 12 cars up the 1.5% grade without any help.

I set the ruling grade to make sure that if we have longer trains they would not be able to get up the grade. In this era it was common for long trains to double the hill instead of adding helpers. I really wanted to model that aspect of operations (doubling the hills).

## Wrapping Up

**Les:** Well Craig, this has been a real treat. Not many people model this era which makes it really interesting and the modeling at Wilson Point is mind boggling! Thank you for having us.

**Craig:** You're welcome! I'm glad you were able to come!

Craig Bisgeier lives in New Jersey and has been interested in model trains since childhood when his parents gave him a hand-me-down Lionel set. As a pre-teen he had an HO scale 4x8 loop layout with a styrofoam mountain. He drifted away in his teens and twenties but got the bug again in the early 90's (1990's!) when a friend brought him to a train club. He's been model railroading ever since.

The 1892 Housatonic Railroad was born in 2003 and is about 70% complete. Craig has a loyal crew of talented friends who have helped to build it and run it. Without them it would not have possible. The credit is a much theirs as it is his own.

He maintains a web site where he posts about construction and op sessions on his layout:

<http://www.housatonicrr.com>



Craig as a young man in 1892.

Craig speaks with great enthusiasm regarding the construction of Wilson Point on his 1892 Housatonic layout. We also include some video of trains moving on the gargantuan pier at the south end of the line.



## Did you see this article in MRH?

### Slim Rails in Stages

Distilling the essence of real-life scenes in HO<sub>n</sub>3

— by Byron Henderson  
[www.LayoutVision.com](http://www.LayoutVision.com)

Figure 1: Cosmetically restored S.P. narrow gauge engine #9 and a brace of cars are preserved with the original station building at the Laws Railroad Museum and Historic Site near Bishop, California. (Courtesy Laws Railroad Museum and Historic Site: <http://www.lawsmuseum.org/>).

**T**he Carson and Colorado (C&C) started with a big dream in 1880: To link its namesake rivers via six hundred miles of three-foot-gauge rails. Although the southward-expanding line was greeted with enthusiasm by local townfolk and businessmen, traffic sources never developed as expected. This prompted the famous (and perhaps apocryphal) quip by one of its owners after an inspection trip, "Gentlemen, we have built this railroad either 300 miles too long or 300 years too soon."

## Model Railroad Hobbyist is loaded with articles like this one in our back issue archives!



## Click to download some back issues today!

# Static Grass Applicators – Times 3!

– by *Kevin Rowbotham*

Photos by the author.



Here are 3 different ways to make your own static grass applicator – and a test of the results from each!

**A**s a model railroader who grew up on the prairies, I have always wanted to model realistic waving fields of wheat or standing hay. Until recent years, I had not seen a method that offered authentic realism without involving a substantial investment of time and tedium. Enter static grass!

With static grass flock and a static grass applicator tool, it has never been easier to create a realistic looking field of tall grass on your layout. Static grass is available in a variety of sizes and colors from various suppliers.

Figure A: 3 Static Grass Applicators.

Grass flocking can be applied by:

- Shaking it on, removing the excess
- Using a squeeze bottle or puffer to puff it onto a glue-covered surface
- “Shooting” it on with an electronic static grass applicator tool.

Using the static grass applicator is the focus of this article.

Of the three static grass applicators I constructed, I based two on [Joe Fugate’s how-to video available at model-trains-video.com](#). Joe’s design was inspired by R.A. Cooke at [www.racooke.com](#).

The third applicator I designed using a modified electronic fly swatter.

The first two use a negative ION generator as their core component.

- One uses a 12 Volt ion generator available from Oatley Electronics, Australia, [www.oatleyelectronics.com](#).
- The second uses a 120 Volt ion generator available from Electronic Goldmine, [www.goldmine-elec.com](#).

As the heart of mass-market air filtration systems, negative ion generators rely on a high voltage, low amperage static charge to remove small particles of dust, dirt and pollen from the air passing through the filter.

Fortunately, we can leverage this technology in model railroading to

add realistic new texture to our terrain in the form of static grass!

All three versions of the static grass applicator depend on this high-voltage/very-low-current technology to generate the static-electric charge.

By shaking the static grass flock through a charged screen over a glue-painted surface that’s hooked to a ground, the grass becomes statically charged and stands upright in the glue. After pulling the applicator away from the surface, the grass remains standing, making for a most realistic “fuzzy” grass effect.

I caution anyone thinking of building the 120 volt applicator. If you are not experienced with safe AC wiring practices, I urge you to stick with the low voltage DC versions! ***These AC voltage levels can kill if you aren’t careful.***

Most miscellaneous parts for the 120 volt build came out of my salvage drawer. I purchased the electrical components for the 12 volt project from B&E Industrial Electronics, [www.be-electronics.ca](#). See the Online Vendors List for details.

I purchased the fly swatter from a discount store. The rest of the supplies can be found at your local hardware or home improvement retailer.

While I used ABS pipe, PVC works as well and has a thinner wall for mounting components.

## Part and Tool Sources

### 12 Volt Electrical Parts

Mouser Electronics – [www.mouser.com](#)

- SPST mini toggle switch – #108-0008-EVX
- Chassis/panel mount coaxial power jack - #163-5006
- LED indicator lamp – #645-608-1132-230F
- 12 volt DC power adapter 200ma - #412-112024

Oatley Electronics – [www.oatleyelectronics.com](#)

- 12 volt negative ion generator - #IONB

120 Volt Electrical Parts

Mouser Electronics – [www.mouser.com](#)

- SPST, (on/off) 125 volt, 1 Amp, panel-mount toggle switch, #108-0047-EVX
- 125 volt neon indicator lamp, #606-6063-001-634R
- Block fuse holder, #441-R345B-GR
- 1 Amp, fast-acting fuse
- Three prong, grounded, AC power cord, #562-211011-06

The Electronic Goldmine – [www.goldmine-elec.com](#)

- 120 volt negative ion generator #GE1783

### Miscellaneous Parts

Mouser Electronics – [www.mouser.com](#)

- Un-insulated Ring Terminal – #644-P18-6R-M
- Alligator Clips – #565-6567
- Heat-shrink tubing assortment – #644-HSTT-YK1
- Kester 63/37 .031” solder, 1 LB. – #533-24-6337-8800

Third Hand Vise

- Micro-Mark – [www.micromark.com](#)

Soldering Irons

- Micro-Mark – [www.micromark.com](#)

- Fast Tracks – [www.handlaidtrack.com](#) ■

## STEP 1: 12V and 120V Chassis Build

OK, let's get started. Because I used nearly identical chassis designs for two of the negative ion generator grass applicator projects, I will first focus on constructing the bare chassis required to build either of the two models. Once the basic chassis is complete, I then cover the wiring details of the two builds separately, since they differ somewhat.

One key difference between the two chassis I built lies in the number, size and location of the holes in the pipe handle to accept components and to provide access for power and the scenic spike, and ground wiring.

If you follow the process I outline regarding the components and wiring of the individual builds, these differences should become clear.

Building the basic chassis is straightforward. First I started with an appropriate length of plastic pipe. I follow others' examples and cut my pipe nine inches in length, see figure 1.1.

After cutting the pipe, I used a knife to remove any resulting burrs from the cut ends. It doesn't take much effort to clean up the cuts.

I took the pipe over to my bench vise where I can support it, so it will not tend to roll as I work on it, figure 1.2. Using my cordless drill, I drilled the holes needed to install the components and allow wiring to enter the applicator chassis. The layout of the holes is somewhat arbitrary.

To simplify and ease component mounting, I spaced my components out near the top of the applicator handle (ABS pipe) and located wiring access holes closer to the flock jar, figure 1.3.



Figure 1.1: I used my compound mitre saw to cut the ABS pipe into 9 inch lengths. A hacksaw or even a crosscut wood saw will work well too.

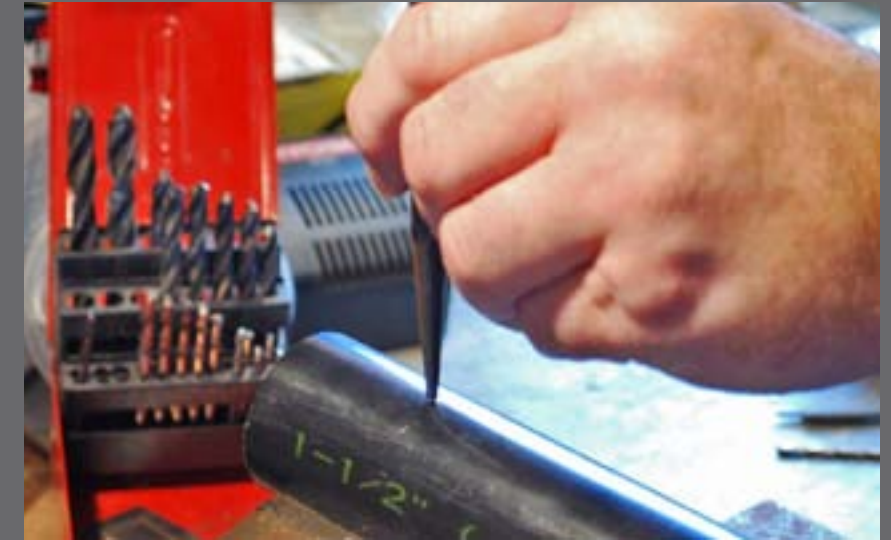

Figure 1.2: I set the cut pipe in my bench vise and used a center punch to create a centering divot to keep the drill bit from wandering.



Figure 1.3: Using my cordless drill along with 1/8", 1/4" and a 1/2" bits, I drilled all the holes needed in the pipe.

## STEP 1: 12V and 120V Chassis Build *continued...*

With the pipe cut and the holes drilled, I set the pipe aside and prepared the other parts of the chassis.

I used the ABS coupler to mark the outside diameter of the pipe on the bottom of the plastic container I chose for the project, see figure 1.4.

From here on, I refer to the plastic container as the “flock jar”. After centering the coupler and marking the circle, I cut out the opening in the bottom of the flock jar, being careful to cut as precisely as possible, figure 1.5.

I wanted this opening to form a nice tight fit with the outside of the pipe to promote a strong connection between the two, figure 1.6.



Figure 1.4: I used the inside of the coupler to mark the outside diameter of the pipe on the bottom of the container.



Figure 1.5: I cut the hole in the container with a utility knife. Doing this project prompted my purchase of a knife set from [Micro-Mark](#), a great MRH sponsor.



Figure 1.6: A tight fit between container and pipe is desirable. This looked close enough to me.



## STEP 1: 12V and 120V Chassis Build *continued...*



Figure 1.7: An appropriately-sized tin can makes a good marking pattern for the lid cut out.

I found a cylinder of the right size and marked the cut line on the flock jar lid, figure 1.7. I cut the lid so there is a one-quarter to three-eighths inch ledge around the circumference of the lid. This ledge gives the aluminum screen a surface to lie against when pressed into the recess in the top of the lid. I was careful to cut *away* from my fingers in case the knife should slip, figure 1.8. I saved the cut out circle from the lid to use later. I used the lid to mark my aluminum screen roughly for size, figure 1.9.

I cut the screen with a pair of “shop” scissors. Trust me; you don’t want to be caught doing this with the wife’s good sewing shears! It is important not to cut the screen too small. I cut the screen and trimmed to fit the lid, figure 1.10. I made the cuts in the garage to avoid little bits of screen wire being tracked around the house.

To finish the lid I drilled a small hole in the plastic ledge for the contact screw, pressed the cut-to-size screen into the lid recess and tacked it in with hot melt glue, figures 1.11 - 1.12.



Figure 1.8: I was careful to cut away from my fingers when I cut the pieces for the project.



Figure 1.9: I used the container lid to mark the aluminum screen to approximate size.



Figure 1.10: I cut the screen a bit large and trimmed it to a close fit.



Figure 1.11: The screen press-fits nicely into the lid recess.

## STEP 1: 12V and 120V Chassis Build *continued...*



Figure 1.12: A quick bead of hot melt glue kept the screen from going anywhere.

As I did not use the ABS coupler for its intended purpose of coupling pipes, I modified it slightly.

There is a ridge inside the coupler at the half-way point that keeps either pipe being coupled from sliding too far into the coupler, figure 1.13. I removed this ridge so the coupler will slide all the way onto my pipe in preparation for gluing. I took the coupler into the garage and clamped it in a vise.

I used my Dremel tool with a multipurpose bit to remove the ridge, figure 1.14. I used a sanding drum in the Dremel tool to further smooth the inner surface so the coupler would not bind as I slid it on the pipe, figure 1.15.

I cut one of the ABS test caps to one-quarter of an inch deep. I used this cap on the end of the pipe that projects into the flock jar. It serves as a cover to keep flock out of the handle and as a surface against which the flock jar will be bonded. I made sure to cut the cap straight so it seated flush against the bottom of the flock jar, figure 1.16.



Figure 1.13: The ridge in the coupler must be removed so it will slide all the way onto the pipe.



Figure 1.14: Using my Dremel and a multipurpose bit, the ridge just peeled away from the coupler's inner surface.



Figure 1.15: A sanding drum chucked in the Dremel smoothed the inner surface so the coupler would slide on without binding.

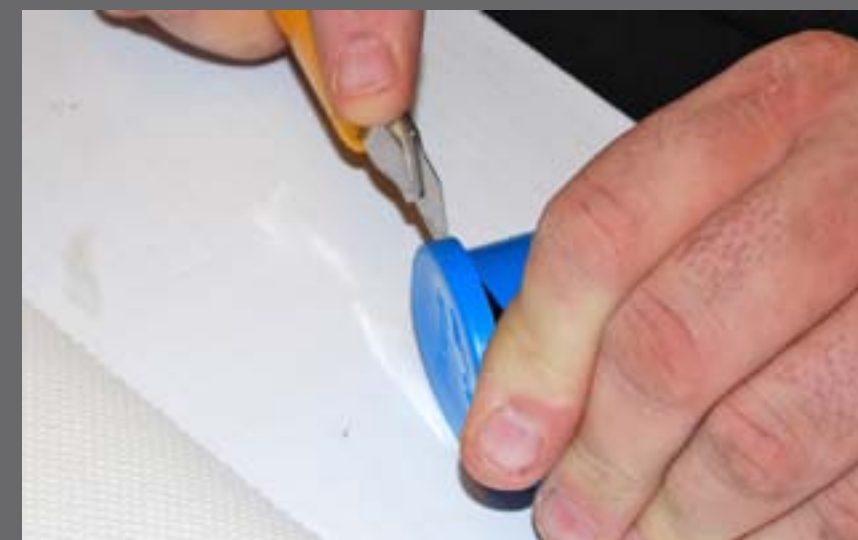

Figure 1.16: I cut down one of the test caps for the inner pipe cap. I was careful to cut away from myself!

## STEP 1: 12V and 120V Chassis Build *continued...*



Figure 1.17: I cut the center from the lid cut out, making a washer for the pipe.

Using the ABS coupler, I marked the outside diameter of the pipe in the center of the plastic cut-out circle I saved. I used a knife to cut the center out of the circle to form a plastic washer, figure 1.17. I used this washer to re-enforce the bottom of the flock jar where the pipe handle passes through the hole in the jar bottom.

With all of the parts prepared, I began assembling the applicator chassis. I used ABS glue, as I had it on hand. Cyanoacrylate (CA) or other glues intended for most plastics will work too. To begin, I glued the modified pipe cap on one end of the pipe. I used a cotton swab to apply the ABS glue to the end of the pipe, see figure 1.18. I applied a liberal coating of glue on the pipe and installed the cap, pressing and twisting it slightly to seat it against the end of the pipe, figures 1.19 & 1.20.

I used a paper towel to clean up the bit of glue that squeezed out when I installed the cap, figure 1.21. ABS glue sets almost instantly, so there's no time for second chances. Be sure you get the cap seated properly on the first try.



Figure 1.18: I used ABS glue that I had on hand to install the modified pipe cap on one end of the pipe.



Figure 1.19: With a liberal coating of glue on the end of the pipe I prepared to install the cap. ABS glue sets fast, so positioning is a quick one-time procedure. No second chances here.



Figure 1.20: Firm downward pressure and a small twisting motion are all it took to firmly seat the cap in place, flush against the end of the pipe.



Figure 1.21: After setting the cap, I cleaned off any excess glue with paper towel.

## STEP 1: 12V and 120V Chassis Build *continued...*

With the cap firmly glued in place, I slid the pipe from the inside, through the hole I cut in the bottom of the flock jar, figure 1.22. I applied a little CA glue around the edge of the cap where it met the bottom of the jar and slid the jar down, seating it against the surface of the pipe cap, see figure 1.23.

I test-fit the plastic washer I made earlier to check for a snug fit around the pipe, figure 1.24. I needed to cut down the outside circumference a bit to make the washer fit the contour of the flock jar bottom, figure 1.25.



Figure 1.22: I slid the handle into the flock jar in preparation for gluing.



Figure 1.23: I applied a little Cyanoacrylate glue to the edge of the cap before seating it against the bottom of the flock jar.



Figure 1.24: I test-fit the plastic washer on the pipe end.



Figure 1.25: I cut a ring off the outer circumference to make the washer fit the jar.

## STEP 1: 12V and 120V Chassis Build *continued...*



Figure 1.26: Before sliding the washer into place, I applied some CA glue.



Figure 1.27: I used the end of my knife to press the washer into the glue.



Figure 1.28: I slid the coupler over the pipe in preparation for gluing.

After trimming the washer, I slid it into place and applied the primer/activator and the CA glue to the bottom of the flock jar, figure 1.26. I used the tip of my knife to press the washer into the glue and to avoid gluing my fingers to the applicator, figure 1.27.

With the washer in place, I slid the pipe coupler onto the pipe, within a few inches of the bottom of the flock jar, figure 1.28. I applied a liberal coating of ABS glue to the pipe, in the area where the pipe coupler was to rest once I slid it into place, figure 1.29.

Once happy with the glue application, I twisted and pushed the coupler against the bottom of the flock jar, see figure 1.30.



Figure 1.29: I swabbed glue onto the pipe where the coupler would sit.



Figure 1.30: I slid the coupler down seating it firmly against the bottom of the flock jar.

## STEP 1: 12V and 120V Chassis Build *continued...*



With the basic chassis complete, figure 1.31, I'm ready to wire the applicator and finish the project. This is the point where the builds diverge. The remainder of these two projects are separate to avoid confusion with wiring the applicators.

I remind you again that if you're not absolutely sure you know what you're doing with the 120V version, don't build it. Voltages this high can kill if you are not careful!

Figure 1.31: The finished chassis.

## Applying static grass

Once I had built each of these applicators, I tried applying static grass flock on a piece of white foam-core with each of them and with the Noch Grassmaster.

I found the power of each tool determined working distances. Even with the most powerful applicator I built, I still must remain within a few inches of the glued surface when applying grass.

Shaking or tapping the applicator causes flock to fall through the mesh screen and land in the glue. If the tool is close enough to the surface, the flock will stand straight up in the glue.

To learn more about how to apply static grass flock to your scenery, check out the scenery video downloads at [ModelTrainsVideo.com](http://ModelTrainsVideo.com).

See the Applying Static Grass video, below, for the results of my application tests. ■

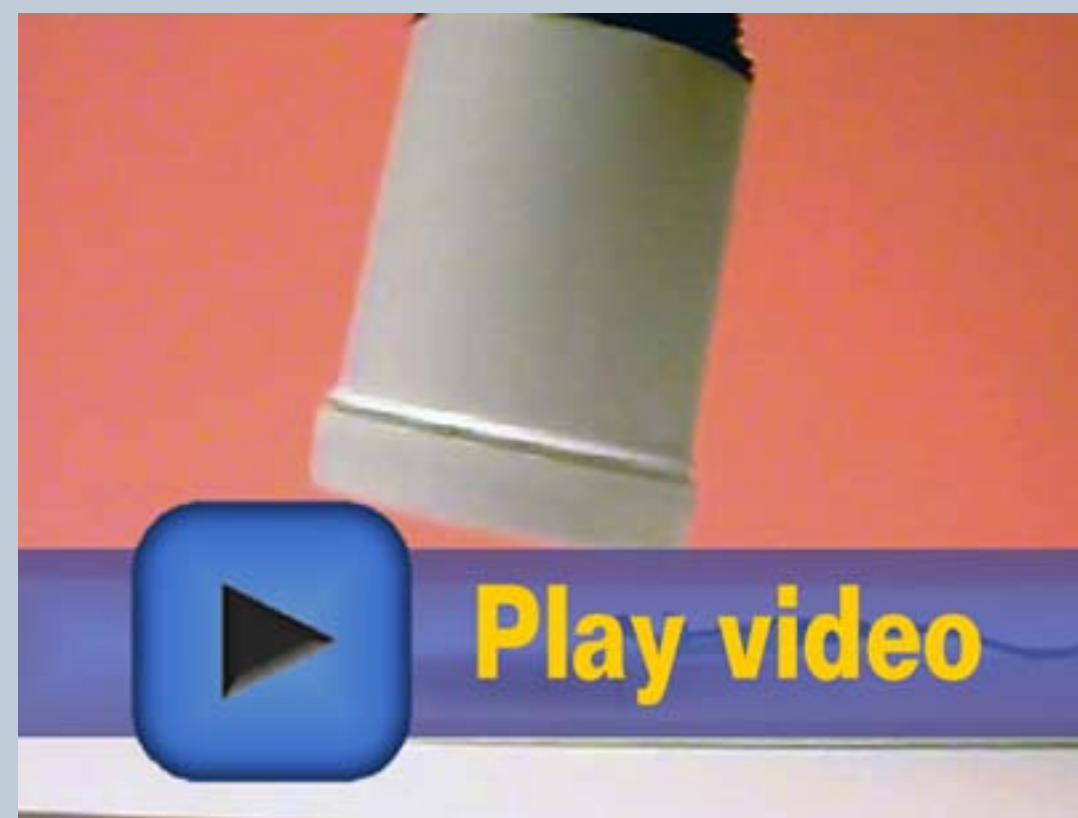

Figure A: Applying Static Grass video.

## TOOLS, IRONS, and SOLDER – Getting Wired!

Now that I have built the chassis to support either the 12 volt or 120 volt static grass applicators, here are some pointers on the tools, materials and techniques for the electrical aspects of these projects.

The most important tool is the soldering iron. While any properly-maintained soldering tool will solder, they are not all the same. For this project I used my 35-watt pistol-grip soldering iron. It has a pointed tip, is compact and maneuverable, and has enough heating capacity for the soldering I needed to do.

Equally important as choosing the right soldering tool is the need to choose the correct solder for the project. I prefer solder with a tin/lead composition of 63/37 and a rosin flux core for electronic/electrical soldering, see figure A. Rosin-core solder with a composition of 60/40 will work too, but it requires a bit more heat to flow. I like a solder with a diameter at or near .032 inches. I avoid the thicker diameter solder for fine electrical soldering because it tends to be harder to control the quantity, requires more heat for a longer time and tends to not flow as well.

The first thing I do before I begin to solder is heat the tip of my iron and wipe it clean with a damp sponge or rag. I then apply the solder to the hot iron tip to tin the tip with solder, figure B. With a good coating of solder on the tip, I gently tap the iron tip over an empty can to shake off any excess solder.

I am a huge proponent of pre-tinning all pieces to be joined with solder. Pre-tinning promotes mechanically-sound, electrically-conductive solder joints, while avoiding the application of too much heat to components.

To make a joint between two conductors or between a conductor and a component terminal, I first make sure everything is physically clean. No dirt, grease or rust is present on any metallic surface to be joined. If wires or terminals appear discoloured, they could be oxidized. Stripping the wire anew can solve the problem, but if it is really bad, the best solution is to apply a liquid rosin flux.

If I don't have liquid flux available, I can still get a good solder joint by letting the rosin flux in the solder's core flow over the connection being made. Either way, if it's not clean I won't get a reliable joint, mechanically or electrically. If everything is already clean, I apply the soldering iron to the conductor or terminal I am tinning. At the same time, I apply the solder at the point where the iron's tip and the metal component meet. As the heat transfers, the flux will begin to liquify and the solder will melt, flowing over the wire or terminal, figure C, D.

*Continued on next page ...*



Figure A: My 35 watt iron and a roll of small diameter 63/37 lead based rosin core solder took care of the soldering for the projects.



Figure B: Pre-tinning the soldering iron with solder is an important first step in assuring a strong electrically conductive solder joint is achieved.

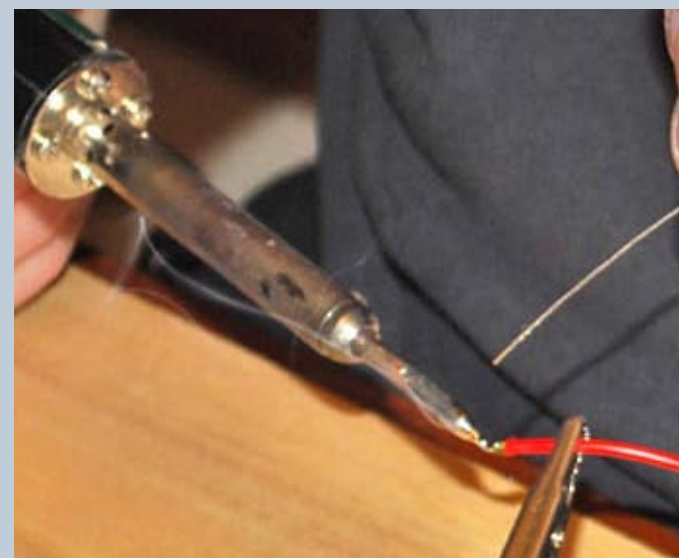

Figure C: Pre-tinning the wires with solder before joining promotes a quick, strong solder joint.



Figure D: Don't forget to pre-tin the component terminals with solder too.

## TOOLS, IRONS, and SOLDER – Getting Wired! *continued...*

One of the best purchases I ever made was my Third Hand Vise, figure E. Soldering is easy, but juggling a component, conductor, soldering tool and solder, while holding a cooling solder joint motionless and not burning your fingers in the process, is virtually impossible.

The Third Hand Vise solves this, figure F. Moving a cooling solder joint makes it weak or limits its ability to properly conduct electricity. This is known as a “cold” solder joint. Cold solder joints are characterized by a blobbed or lumpy, dull appearance. Good solder joints are usually smooth and shiny. Using some sort of vise promotes good solder joints.

While electrical tape is an adequate insulator, it is hardly ideal or appropriate for the small conductors and terminals in modeling. I recommend keeping an assortment of heat-shrink tubing on hand, figure G. Heat-shrink is the best material for insulating small connections, *any* connections. It’s tough, comes in a variety of colors and sizes and moulds itself around the small parts being insulated in a way that can’t be reproduced with tape.

Once I have shrunk the tubing on a connection, it is protected from shorting. I believe the shrink tubing makes smaller gauge wire connections more durable, helping to prevent the conductor breaking off at the insulation.

A few hand tools are a must for wiring these projects, figure H. I find most wiring projects are easier to complete with better results when using quality tools. Good quality diagonal cutting pliers, wire stripping pliers and a pair of needle nose pliers are three must-have tools for any wiring project. I also used the following tools to complete these projects:

- screwdrivers,
- crimping pliers,
- a pair of scissors,
- a hobby or utility knife and
- medium and fine-tip marking pens.

In addition to the soldering tool, I used three other power tools to assemble the grass applicators:

- A variable speed Dremel tool with attachments,
- a cordless drill, and
- a compound mitre saw; however, a hand saw will work too. ■



Figure E: A handy vise like this one can save a lot of headaches when soldering or doing anything that has your hands full and trying to position small parts for joining.



Figure F: With an iron in one hand and solder in the other, you’re hard-pressed to hold the wire steady while soldering. The Third Hand Vise easily solves this problem.



Figure G: Heat-shrink tubing, what a great invention! Slide it over a bare connection, apply a bit of heat and in seconds you have a tightly-wrapped, insulated connection. Covering small gauge wire connections with heat-shrink tubing helps avoid breakage from repeated flexing of fine conductors.



Figure H: The tools of the trade. If you are going to do much electrical wiring, these are some of the essential hand tools you’ll need to have in your tool box.



## STEP 2: 12V Applicator Wiring

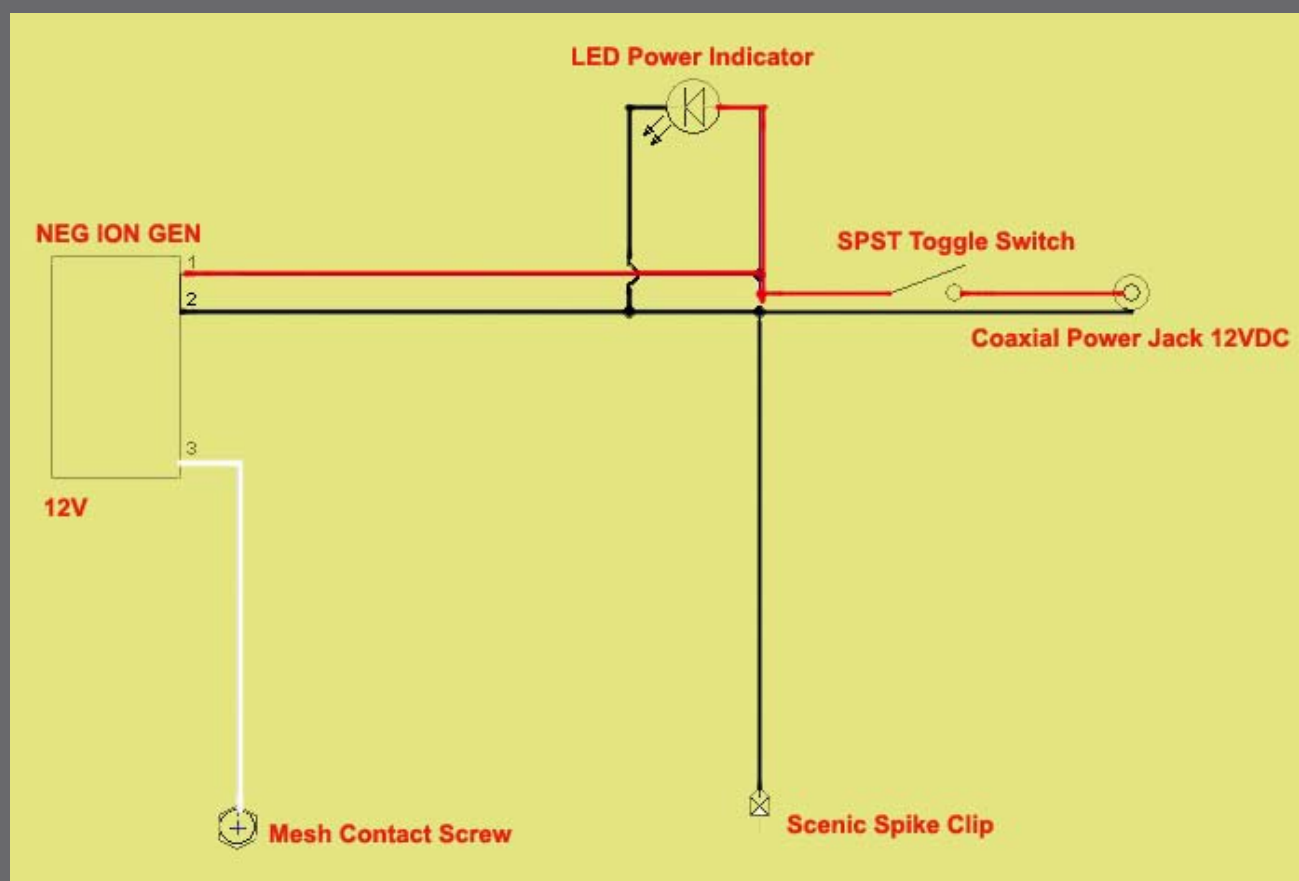

Figure 2.0: Positive power enters the circuit through the chassis jack, through the switch feeding the LED and the ion generator. The negative side of the circuit completes the LED and ion generator circuits and is the scenic spike ground connection.

With the chassis complete and having touched on the tools required I am ready to begin the 12 volt applicator wiring. The wiring for the 12 volt applicator is straightforward, see figure 2.0.

## 12 Volt Static Grass Applicator Materials List

QUANTITY	ITEM
1.....	9" length of 1-1/2" ABS pipe
1.....	1-1/2" ABS pipe coupler
2.....	1-1/2" ABS test cap
1.....	Clean, empty, approximately 16 oz., 500ml plastic container with lid
1.....	12 Volt DC negative ion generator, Oatley Electronics #IONB
1.....	SPST Mini toggle switch, Mode Electronics #41-210-1
1.....	2.1mm power jack, chassis-mount
1.....	12 volt DC LED power indicator lamp
3 feet .....	16 gauge stranded single conductor electrical wire
1 foot .....	18 gauge stranded electrical wire
1.....	Standard, medium sized un-insulated alligator clip
1.....	1/4" - #4-40 machine screw
1.....	1/8" washer
1.....	#4-40 hex nut
1.....	Small ring or fork terminal
	Aluminum Window Screen, enough to cut out a circle for the container lid
	Cyanoacrylate adhesive, (CA glue)
	ABS solvent cement – or use CA
	Assorted heat-shrink tubing
	60/40 or 63/37, 0.81mm lead based solder or similar electronic grade solder ■

## STEP 2: 12V Applicator Wiring *continued...*

The LED power indicator requires particular attention. LED's must be wired with the correct polarity. The positive lead on an LED is called the anode and the negative lead is the cathode.

For most standard LED's, the cathode is the shorter of the two leads, figure 2.1. If the LED has a flat side, the cathode is closest to it. Alternately, if you can see the "guts" of the LED through the diffuser, the cathode is the lead with the larger mass of material on the end embedded in the LED, figure 2.2.

The DIALCO 559-0103 LED with built-in resistor that I chose, figure 2.3, is rated 12 volts DC with a minimum 13 milliamps (mA) of forward current through it to illuminate.

I tested the LED in a circuit with my chosen wall adapter power supply, rated at 12 volts, 200 mA and measured an acceptable 16 mA of forward current in the circuit. The power supply I used is unregulated, so without a load its output is actually 14.95 volts.



Figure 2.1: LED's come in many colors, shapes, and sizes and are identified in different ways. These two are identified by the shorter cathode (negative) lead.

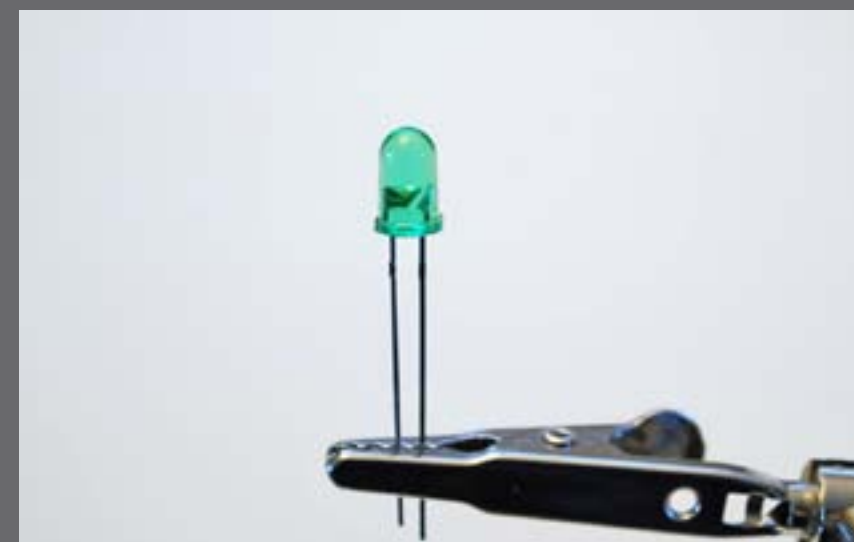

Figure 2.2: The cathode has the largest mass in an LED – another way of determining polarity.



Figure 2.3: The Dialco LED I used has a built in resistor and is rated at 12 volts.



Figure 2.4: I soldered the LED wire leads on and added insulation to its bare leads to avoid shorts.

## STEP 2: 12V Applicator Wiring *continued...*

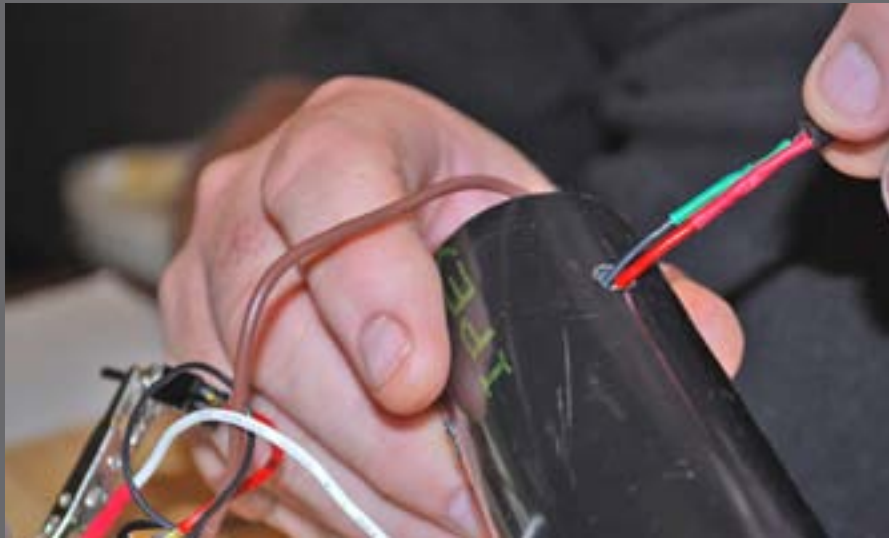

Figure 2.5: I fed the leads and LED into the hole I had drilled.

To prepare the LED, I soldered a red wire lead to the LED's anode (positive lead) and a black lead to the cathode (negative lead), figure 2.4. I insulated the LED's bare leads with heat-shrink tubing and fed the leads through the chassis hole, added a drop of CA glue, and pressed it in place, figure 2.5.

Power enters the applicator via a chassis-mount coaxial power jack, figure 2.6. The wall adapter has a center-post positive polarity, so I wired the chassis jack to match, soldering a red lead onto the center terminal, figure 2.7. The positive lead from the coaxial jack routes power to one terminal on the SPST toggle switch, figure 2.8.

To complete the positive half of the circuit, I made a joint between the ion generator's positive lead and the red LED lead by twisting the wires firmly together and soldering, then soldering the resulting joint to the second terminal on the toggle switch. Figure 2.9 shows the wired switch and the chassis jack at the mouth of the handle, awaiting the completion of the negative half of the wiring before being installed in the pipe wall.



Figure 2.6: DC Chassis Jack.



Figure 2.7: I soldered the positive lead to the jack's center terminal, the hand vise made that an easy task.

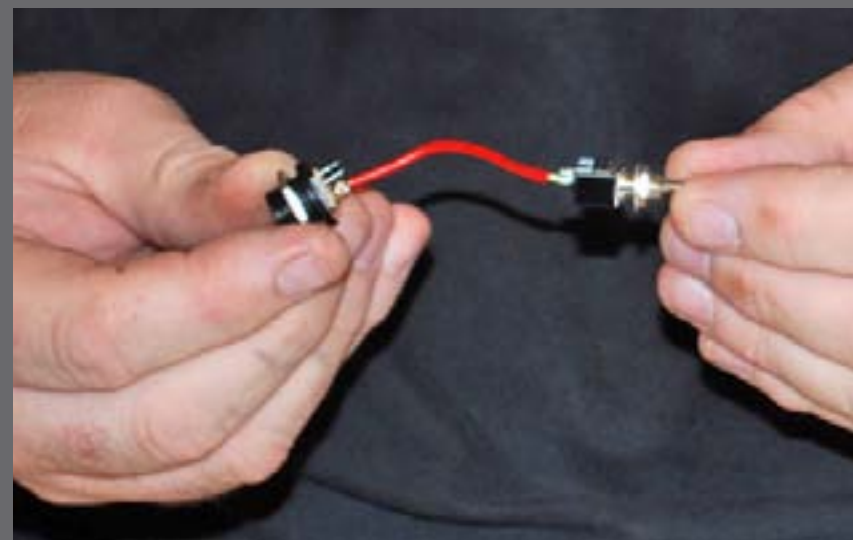

Figure 2.8: I soldered the positive power lead to the SPST switch.



Figure 2.9: Red leads route power from the jack to the switch and then on to the LED and ion generator positive leads. With the positive portion of the component wiring complete, all that remained was to make the negative connections.

## STEP 2: 12V Applicator Wiring *continued...*



Figure 2.10: My vise helped me hold the two wires steady, side by side, while I soldered the heavier wire onto the delicate charge wire from the ion generator.

The white wire from the 12V negative ion generator is the static charge wire. The ion generator I used has a small brush on the end of the wire which I cut off and discarded. I found this wire to be a bit delicate when the lid is opened and closed to add and remove flock. To eliminate this potential failure point, I soldered a piece of heavier 16 gauge stranded wire to the charge wire, insulated it with heat-shrink and fed it out the bottom of the handle into the flock jar, see figures 2.10, 2.11.

I finished the flock jar wiring by soldering a ring terminal onto the charge wire, figure 2.12. A #4-40 machine screw, nut and washer gave me a solid connection between the charge wire and the screen lid, figure 2.13.

I twisted the black wire from the ion generator together with a 36 inch length of 16 gauge stranded wire, and soldered them together, to the negative (ground) terminal on the coaxial jack, figure 2.14.



Figure 2.11: I fished a length of 16 gauge wire through the hole in the cap before making the solder joint with the charge wire.



Figure 2.12: With the charge wire cut to length, I used my vise again to make short work of soldering the terminal end onto the charge wire.



Figure 2.13: To complete the charge screen wiring I added red heat-shrink as a reminder of the shock potential here and used a machine screw and washer to make a solid connection with the screen.



Figure 2.14: Soldering the scenic spike wire and the negative (black) ion generator wire to the chassis jack was a simple task with the help of my vise.

## STEP 2: 12V Applicator Wiring *continued...*



Figure 2.15: I used knots in the wire to act as strain relief inside the handle.



Figure 2.15a: I soldered an alligator clip to the wire end.



Figure 2.16: With everything wired up, I was ready to install the components.

I tied a knot in the wire as a strain relief and fed the wire down the pipe through the chassis hole for the scenic spike ground wire, figure 2.15. I slipped the negative ion generator into the pipe and took up the slack in the wires exiting the handle. I adjusted the slack in the scenic spike ground wire and soldered an alligator clip to the wire end, figure 2.15a.

I tucked the wires gently into the handle as I inserted the toggle switch and chassis jack into their respective holes, see figures 2.16, 2.17. Once I was happy with the fit, I installed a full size ABS test cap on the top of the pipe without glue so I can open it again later if needed, figure 2.18.



Figure 2.17: Last in was the toggle switch.



Figure 2.18: I slipped the second un-modified test cap over the end of the pipe to complete the build. I didn't glue the cap in place to allow ease of access later for servicing.



### STEP 3: 120V Applicator Wiring *continued...*

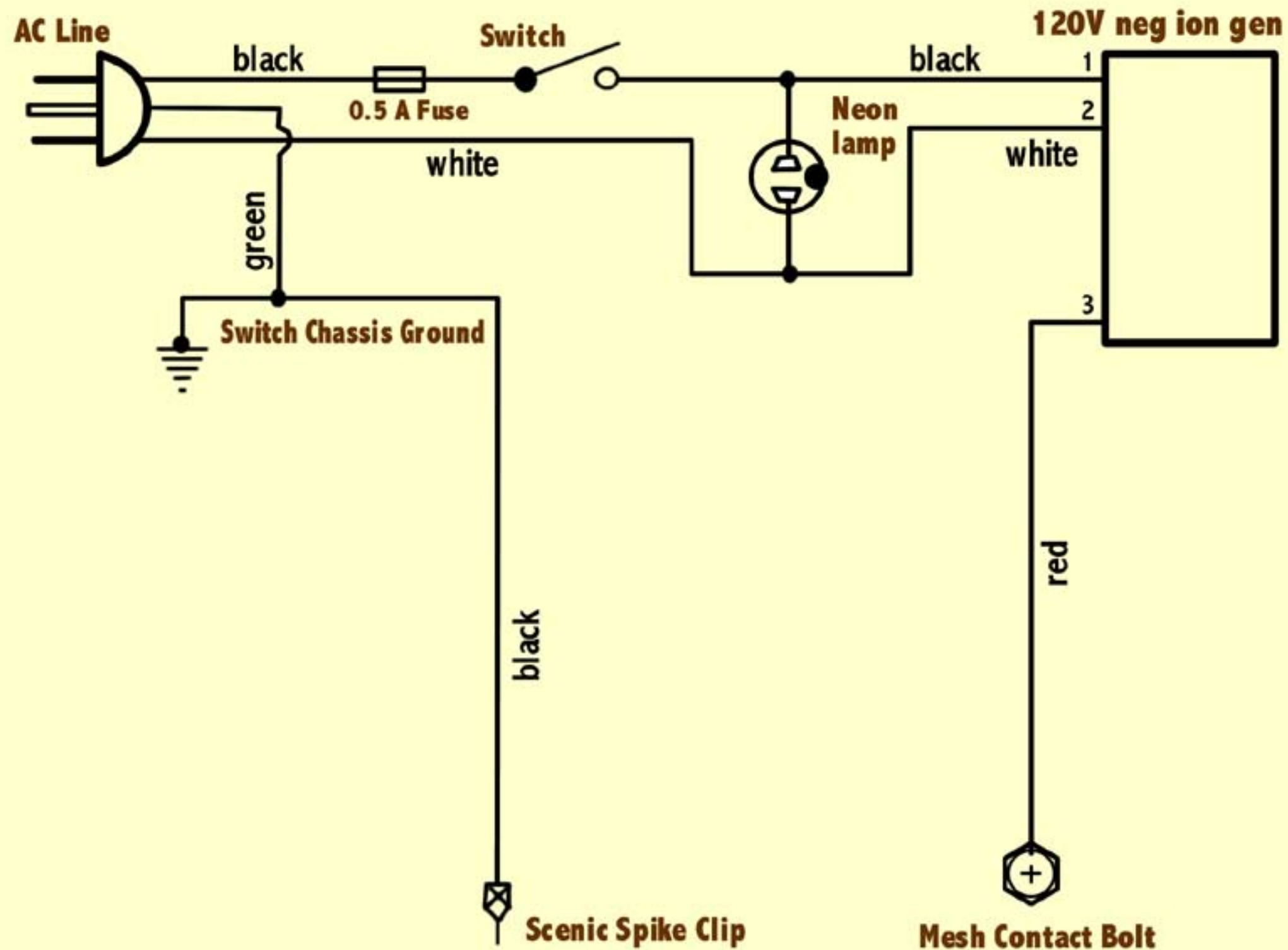

Figure 3-1a: 120v wiring diagram.

### STEP 3: 120V Applicator Wiring *continued...*

I used a 3-wire, grounded AC electrical cord for safety. Mine is a computer power supply cord, figure 3.2.

The 120 volt negative ion generator has three wires. The red wire is the charge wire. The black wire is live AC power and the white wire is the common or neutral wire, figure 3.2a.

The ion generator comes with a molded plastic mount that I removed in order to fit the part into the chassis handle, figure 3.3. I used my Dremel tool and a multipurpose bit to remove the mount, and was careful not to cut into the body of the ion generator, see video 1 (figure 3.4).



Figure 3.2: The AC power cord I used came from an old computer power supply. Any three pronged, three wire, AC cord should be fine.

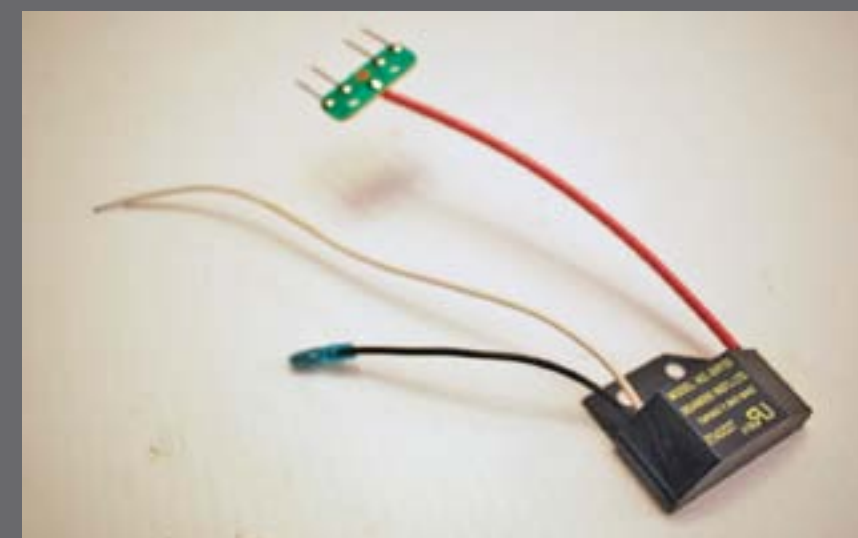

Figure 3.2a: The 120 volt negative ion generator from Electronic Goldmine. For my purposes, I removed the pins from the red charge wire.



Figure 3.4: Video 1 – Removing the flange.

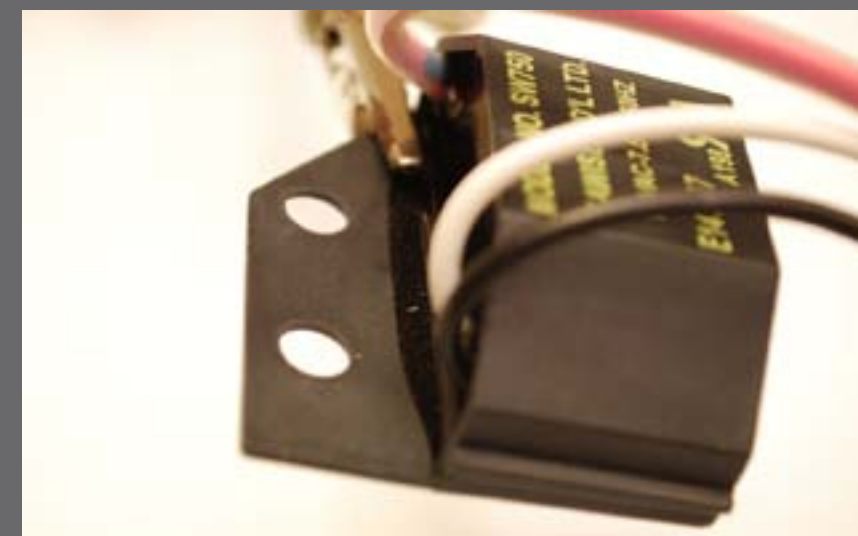

Figure 3.3: The molded bracket must be removed in order for the component to fit inside the pipe handle of the applicator.



### STEP 3: 120V Applicator Wiring *continued...*



Figure 3.5: I salvaged the power switch and neon lamp for the project. Comparable substitutions can be found in the online tool & parts list.

The push on-off switch and the neon lamp came out of an old range. Both components have wire leads attached from the factory, figure 3.5. Because this applicator is powered with AC line voltage, the live line should be fused to add a level of protection for the user. I used a 1-amp fast-blow fuse, it was the lowest rated fast blow fuse I could find at my local supplier. A fuse with a rating of  $\frac{1}{2}$  amp would be better. The fuse block I used is from my scrap drawer. It's a surface mount type similar to figure 3.6, except it has male spade terminal ends for contacts. I chose this type because I had it on hand. You could also use an inline type similar to figure 3.6a. Make sure it is rated for at least 120 volts.

I tied knots in both the AC cord and the scenic ground wire. The knots act as a strain relief inside the handle avoiding any tugging on the internal wiring, figures 3.7, 3.7a.



Figure 3.6: This project needs to be fused for safety. I used a surface mount fuse block I had on hand and a 1-amp fast-blow fuse.



Figure 3.6a: An inline fuse holder rated for 120 volts is fine too.



Figure 3.7: I tied a knot in the cord to act as a strain relief and avoid any tugging on the internal wiring.



Figure 3.7a: Similarly, a knot in the scenic ground wire avoided stress being applied to wiring inside the handle.

## STEP 3: 120V Applicator Wiring *continued...*



Figure 3.7b: I fished the scenic ground wire through the hole in the handle.

I fed the power cord and scenic ground wire through the holes in the handle, figure 3.7b.

I cut the moulded end off of the AC cord, and carefully cut the cable sheath back to expose the wires, figure 3.8. I was careful not to cut the insulation on the individual wires. If I did nick the insulation I used heat-shrink to insulate the cut, but if the wire itself was nicked, I cut it off and start over again. I stripped the ends of the wires and tinned them with solder. I slipped heat-shrink on the live wire from the AC cord and soldered on a female spade terminal end, see figure 3.9. I slipped the heat-shrink over the terminal end and shrank it with the heat from the barrel of my soldering iron.

I placed heat-shrink on one of the leads from the on-off switch and soldered a spade terminal to the wire, see figure 3.10. I insulated that terminal end with heat-shrink. I used larger heat-shrink over each wire with a terminal attached and connected the two wires to the fuse block, then slid the heat-shrink over the spade connections to insulate the exposed live fuse block connections, figure 3.11.



Figure 3.8: I stripped the sheath on the AC cord back to expose the wires, being careful not to cut the insulation on the individual conductors.

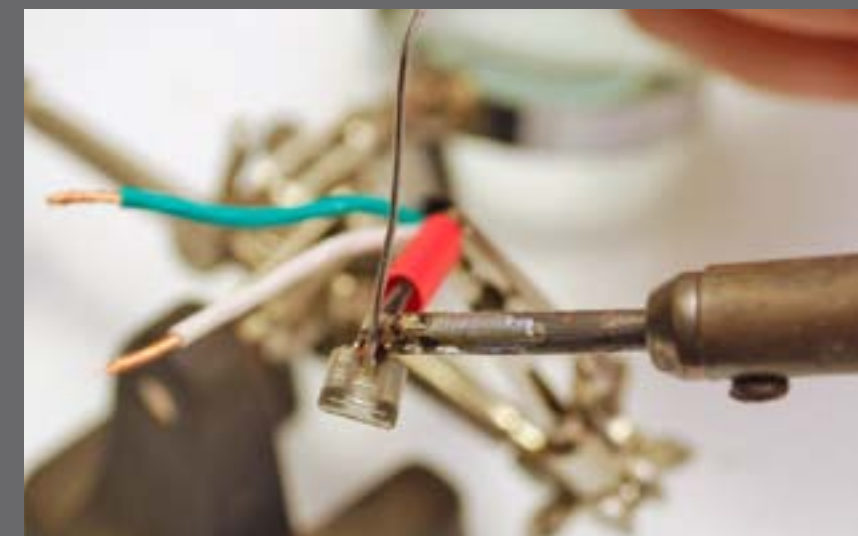

Figure 3.9: The fuse block I used has male spade terminal contacts, so I soldered a female spade terminal on the AC cord live (black) wire, making sure to slip a length of heat-shrink over the wire before soldering.

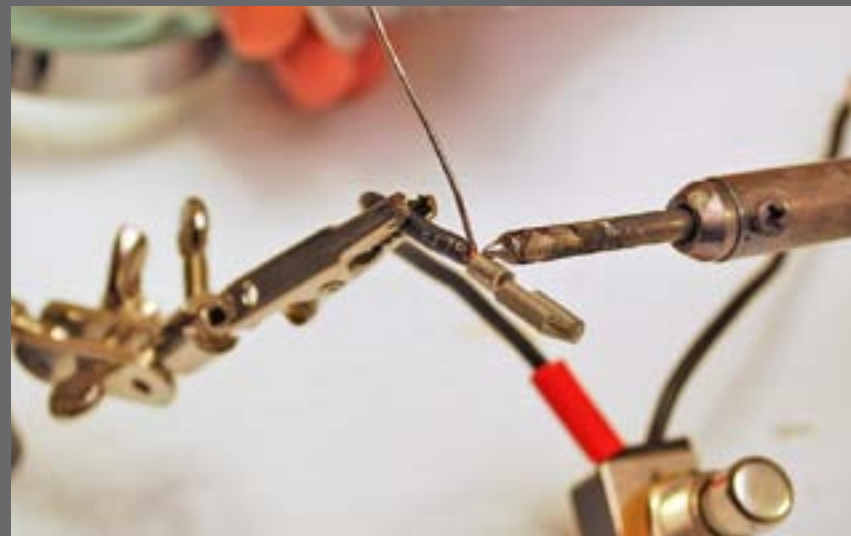

Figure 3.10: Like the AC cord live wire, one of the wires on the power switch needed a female spade terminal installed.

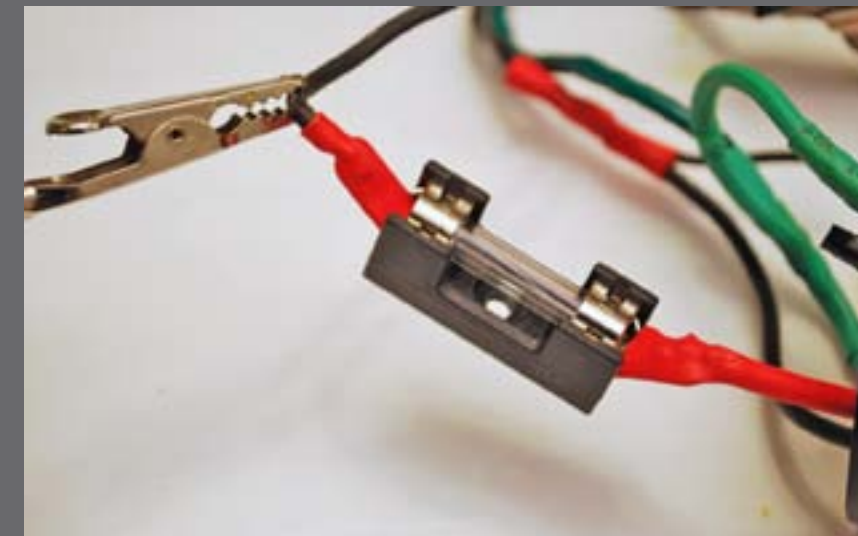

Figure 3.11: I used heat-shrink to insulate the protruding terminal connections on the fuse block. An inline fuse would be better here, as there would be no exposed live contact points. I made sure to position the fuse block so it would not come in contact with any other conductors.

### STEP 3: 120V Applicator Wiring *continued...*

I put heat-shrink in place, then connected the second wire from the switch and the black lead from the ion generator, with one of the leads from the neon lamp. I placed my heat-shrink, then soldered and insulated the joint, figure 3.12.

I connected the other lead from the neon lamp and the white lead from the ion generator to the white wire from the AC cord using heat-shrink and then soldered it, figure 3.13.

Because the push-button switch I used had an exposed metal button and threaded shaft, I placed a large ring terminal with ground wire attached around the barrel of the switch, see video 2 (figure 3.13a). I connected this ground wire to the scenic spike ground wire and soldered them both to the AC cord ground wire, using heat-shrink to insulate the connection.



Figure 3.12: All of the soldered connections were tinned prior to soldering and insulated with heat-shrink. Here I am soldering the joint between the second switch lead, the neon lamp lead and the power lead from the negative ion generator.



Figure 3.13a: Video 2 – Switch Grounding.



Figure 3.13: I soldered the common, (white) wire in the AC cord together with the white wire from the ion generator and the second lead on the neon indicator lamp.

### STEP 3: 120V Applicator Wiring *continued...*

I found the charge wire on the negative ion generator to be a bit fragile so I used a length of 16 gauge stranded wire soldered onto the end of the charge wire, then fed the wire into the flock jar from the handle, figure 3.14.

With the internal wiring connections made and insulated, I slid the ion generator into the handle and tucked the wiring into the handle, slipped the fuse block in out of the way, and installed the switch in the chassis hole. I pulled the AC cord and ground spike wires out until the strain relief knots contacted the wall of the pipe, then slipped the neon lamp in place. I installed the test cap on top, completing the internal wiring of the project, figure 3.15.

I cut the 16-gauge charge wire to length and soldered a male spade terminal onto the end of it, see figure 3.16. I covered the charge wire in red heat-shrink as a reminder of the potential charge present there, figure 3.16a.



Figure 3.14: I substituted a 16 gauge stranded copper wire for the charge wire from the ion generator. I found the charge wire to be a bit fragile when removing the screen lid to add flock.



Figure 3.15: I slipped on the cap, finishing the internal wiring for the 120V applicator.



Figure 3.16: I soldered a male spade terminal onto the end of the charge wire.



Figure 3.16a: I covered the charge wire in red heat-shrink as a reminder of the shock potential.

### STEP 3: 120V Applicator Wiring *continued...*



Figure 3.17: I soldered the alligator clip onto the end of the scenic ground wire.



Figure 3.18: I made this custom terminal so I could remove and change screens quickly and easily without having to loosen the mesh contact screw.



Figure 3.19: I crimped the ring terminal wire end.

I stripped the end of the scenic ground wire, tinned it and soldered an alligator clip to the wire, figure 3.17. Finally, I made a custom terminal end for the aluminum screen contact, figure 3.18. I took a small ring terminal and crimped the end so that it formed a small pin, figure 3.19, 3.19a.

I inserted the pin into the wire crimp end of a male spade terminal end, crimped it and soldered the connection, figure 3.20. I slid the ring terminal onto the screen lid contact screw and tightened the nut. The custom terminal makes it easy to remove the screen lid or change lids.

That completes the 120 Volt grass applicator. Now to lay down some static grass!



Figure 3.19a: I used the crimps to create a "pin" I could insert in the spade terminal wire end.

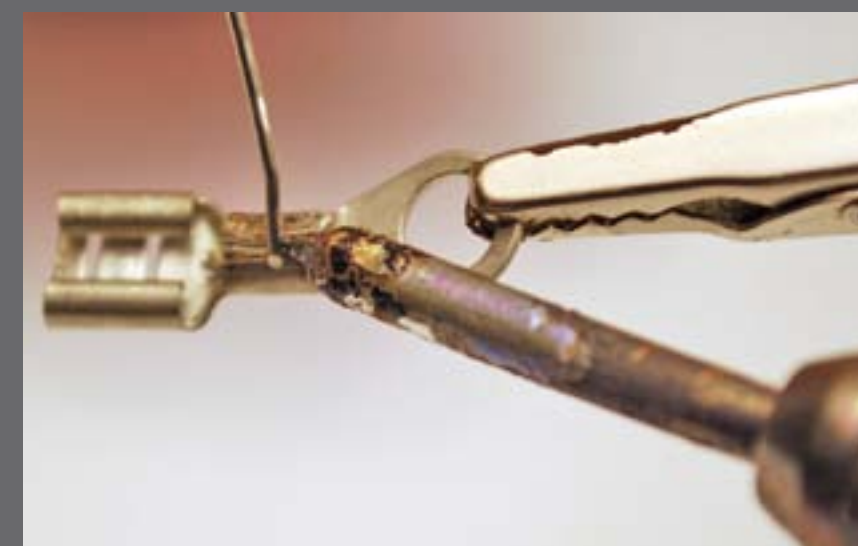

Figure 3.20: I crimped the spade terminal onto the pin of the ring terminal and soldered the connection.

## STEP 4: Fly Swatter Applicator Wiring

After reading posts in the forums about modifying electronic fly swatters to make static grass applicators, I completed my own research on the subject. I found a few examples online, but they all seemed to follow a design made popular by a YouTube video from "thebig61". Those applicators use a metal sieve attached to the fly swatter handle. I felt I could do a better job, so here's my version of the applicator.

I started with an electronic fly swatter purchased from a "Big Box" retailer for around \$5.00, Canadian. It is powered by two AA batteries, has a momentary push switch and an LED power indicator, figure 4.1. Before I began building my applicator, I dismantled and modified the fly swatter.

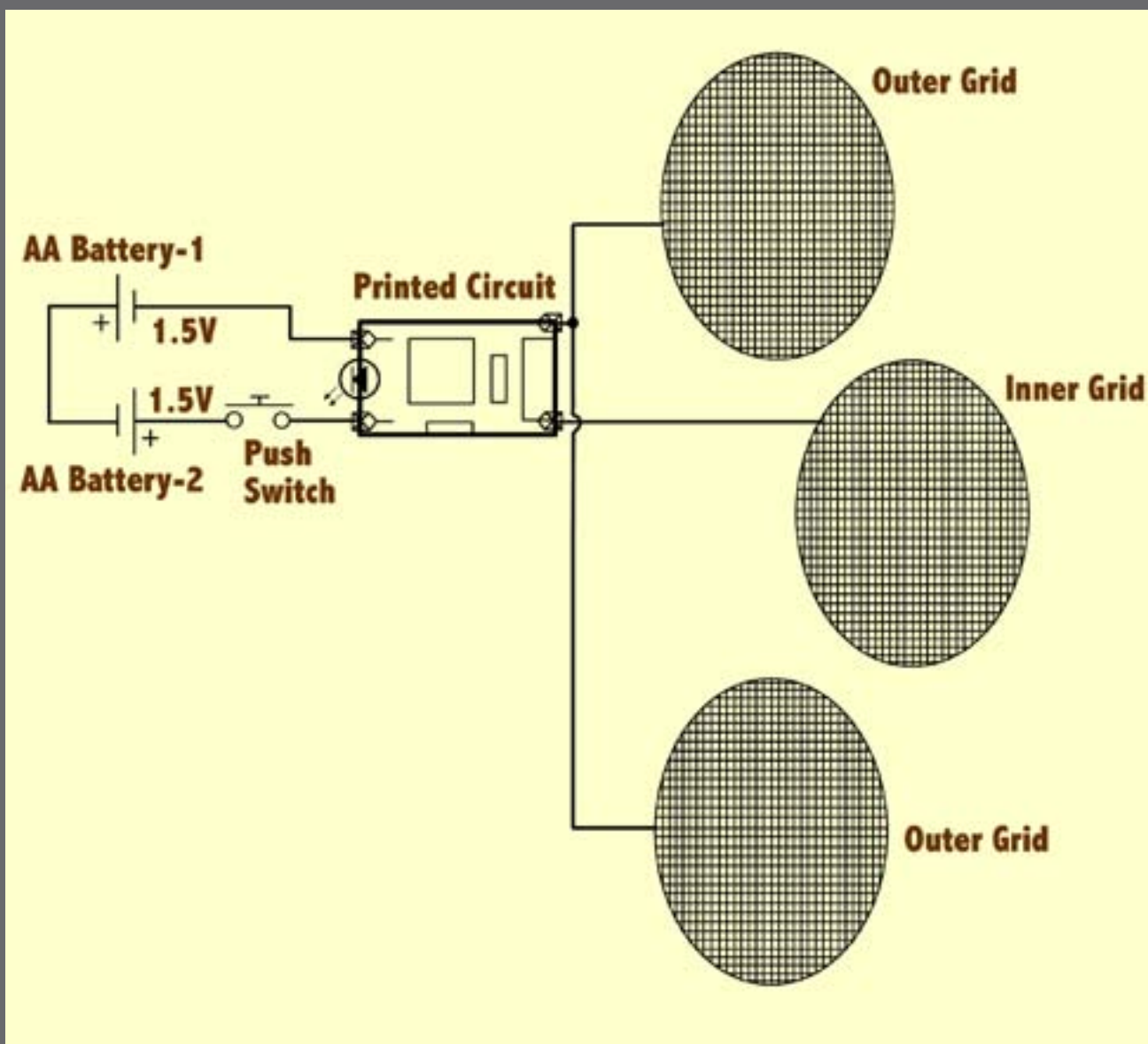

Figure 4.0: The original fly swatter wiring showing grid connections.

## STEP 4: Fly Swatter Applicator Wiring *continued...*



Figure 4.1: A "no frills" electronic fly swatter.

## Fly Swatter Static Grass Applicator Materials List

QUANTITY	ITEM
1.....	Big Box Retail AA battery powered electronic fly swatter
1.....	Clean, empty, approximately 16 oz., 500ml plastic container with lid
3 feet .....	16 gauge stranded single conductor electrical wire
1.....	Standard, medium sized un-insulated alligator clip
1.....	¼" - #4-40 machine screw
1.....	1/8" washer
1.....	#4-40 hex nut
1.....	Small ring or fork terminal
	Aluminum window screen, enough to cut out a circle for the container lid
	Support material, could be styrene, plastic corrugated sign board, masonite, etc.
	Cyanoacrylate Adhesive, (CA Glue)
	60/40 or 63/37, 0.81mm lead based solder or similar electronic grade solder ■

## STEP 4: Fly Swatter Applicator Wiring *continued...*

I removed the batteries and all of the handle screws, including the one hidden beneath the quality-control sticker. With the screws removed, the handle separated easily. I made certain not to lose the plastic switch actuator button as I opened the handle. With the handle apart, I removed the final screw attaching the grid frame to the handle. I planned to later replace the wires connecting the metal grids to the circuit upon re-assembly, so I removed the screw securing the circuit board and set the loose parts safely aside until later.

I inserted a flat screwdriver tip at the base of the frame and twisted it slightly, splitting the frame along the seam. I continued around the frame until I had the frame split in half. I removed the plastic grid spacers and separated the three grids.

This particular swatter had two outer grids that are grounded and an inner charged grid. With the frame and handle apart, it was obvious which terminal was ground and which was the charge terminal on the capacitor. I made note of the polarity and de-soldered the wires from the circuit board.

See the disassembly video.

While the circuit board was out of the handle, I performed the circuit modification I felt was needed. The swatter includes a resistor bridging two capacitor contacts. The resistor “bleeds down” the charge from the capacitor, presumably so the swatter is not left with a charge. In a test, I noticed once I released the switch, the charge dropped very quickly, so it seemed logical to remove this component from the circuit.

I snipped the leads on the resistor close to the circuit board and removed it. See circuit mod video. Now a single press of the button charges the capacitor and the charge remains until the ground spike is touched or sufficient charge dissipates through grass application. If the static field seems to be waning, a short press of the button instantly recharges the capacitor. I expect the batteries will last longer as a result and like that I don't have to hold a button while applying grass. When I finish using the applicator, I touch the ground clip to the charge wire attachment screw to fully discharge the capacitor.



Figure 4.2: Disassembly Video



Figure 4.3: Circuit Modification Video

## STEP 4: Fly Swatter Applicator Wiring *continued...*

### Frame Modifications and Assembly:

I wanted to mount a flock jar to the swatter, so I cut the existing frame to fit and added two pieces of corrugated plastic sign board as spacer and support pieces. I cut the spacer and support to fit inside the frame, making holes where needed to allow plastic assembly pegs in the frame to penetrate.

The corrugations in the sign board provided a wiring channel to run the charge wire through from the base of the frame. I cut a hole in one surface of the sign board support to correspond with a hole had cut in the bottom of the flock container. I fished the wire through the hole into the channel in the sign board and into the base of the frame. Once I had the wire routed through the frame, I glued the two frame halves back together with Cyanoacrylate (CA) glue.

I fed the charge wire through the hole in the flock container, then glued the container to the support piece and modified frame. I mounted the frame back into the handle with the original screw. I solder the charge wire onto the circuit board, leaving a small loop in the wire for slack.

I drilled a small access hole for the ground spike wire in the handle and passed a length of 16 gauge wire through the hole. I soldered this wire to the negative capacitor contact on the circuit, tucked the wires in place and secured the circuit board with the screw.

I placed a piece of red heat-shrink over the charge wire in the flock jar to serve as a reminder of the shock potential there, and soldered a small ring terminal on the wire. I cut the flock jar lid to accept the aluminum mesh and attached the wire to the screen lid using a #4-40 machine screw. Finally, I put the handle back together and replaced the screws.

Ready to apply some static grass!



Figure 4.4: Applicator Build Video.



## Conclusions

I enjoyed building these grass applicators and testing them alongside the Noch Gras-Master. My electroscope tests show the 120 volt applicator to be the most powerful of the four.

I give the highest marks to the 120 volt applicator; it needs no adapter, it is the most powerful of the three and the 120V ion generator is currently available in the US for under \$5.00! The main drawback with the 120 volt design is the AC line current. If you are not experienced with AC wiring, don't build it!

The 12 volt applicator is a close second to the 120 volt and rates very similar to the 9V Noch Gras-Master. The Noch differs from the applicators I built in that it has a charge plate

located *at the back* of the flock jar rather than a charged screen.

The Fly Swatter applicator, the least expensive and easiest to build, has the weakest charge. Even so, it also works for applying static grass – you just have to make sure you hold it *very close* to the application area.

All of these applicators work. If you can justify the cost of a Noch Gras-Master, you prefer not to bother building this kind of tool, and you want to support a great model railroad company, go ahead and buy the Noch. It works just fine.

If you're on a tight hobby budget or you like building neat tools for the hobby, then build one of the applicators I've shown you here. All it takes is an evening or two and some simple supplies! 

## Electrostatic Testing

Laying down static grass with the different applicators is a fair test of their ability, but I wanted to see and compare the strength of the static charge produced by each version of the applicator. I don't have an electrostatic voltmeter in my model railroader's toolbox (who does) and they are too expensive. Being a thrifty modeller, I opted for a homemade Electroscope.

The first Electroscope, invented by William Gilbert, was called a Versorium. It was the first electrical measuring device used to detect and reflect the presence and magnitude of an electrical charge in an object.

The Electroscope I built is a variation on the gold leaf Electroscope. Static charge is detected by the Electroscope's charge collector and conducted through the copper rod to the foil leaves. Because the leaves receive the same polarity of charge, they are repelled from one another and spread apart. Like charges (polarities) repel, while opposite polarities attract. The more charge that is present, the more the leaves repel. When the collector is touched by ones hand the charge is bled off through the body.

See the Electroscope video, below. ■



### Kevin Rowbotham

Kevin grew up on the Canadian Prairies, listening to the sound of CN freights and yard switchers working on wintery Saskatchewan nights. He loved trains at an early age; reading train stories, rail fanning and, after Christmas 1975, HO railroading with a set found under the tree.

He already had a keen interest in electricity and electronics. Model railroading provided another outlet for that interest. Not long after Christmas, a sheet of plywood was purchased, track was laid, wires were strung, and a model railroader was born. The rest is history.

Kevin still lives on the plains of Saskatchewan with his wife Arla, and their two sons, Noah and Ethan. His other interests include: his family, reading, photography, video and editing, music, electronics, and old Chevy trucks.



Figure A:  
Electroscope  
Video.

# ExactRail *Trinity* Box HyCube



– by Jeff Shultz



The ExactRail 50 ft. Hy-Cube boxcar is part of ExactRail's Evolution Series and is already in its second run.

Based on the information available from the New Build Tables at <http://railroadcarhistory.com> and Darrell Sawyer of *Freight Cars Illustrated* (<http://fcix.com>), this car represents a prototype that was built between August and December of 2004 for TTX. Wearing the FBOX reporting mark, the first series of cars is numbered 504400-504799 and the second series is 505200-505399.

So far all of the FBOX cars released have been from the second batch of numbers. The prototype is a 6275 cuft boxcar, TTX class XRH52, which has a 12ft wide by 12ft 4in tall Stanrail door and rides on 100-ton trucks.

There was some controversy online when this model was first released, as it also came in paint schemes for Canadian National (CN) and Southern Railway of British Columbia (SRY).



Those cars are actually a similar, slightly smaller prototype. The current run of this model includes only the FBOX roadname.

The model features McHenry #41 scale knuckle couplers, see-through end platforms, scale 36 inch metal wheels in very detailed 100 ton trucks, with full underbody detailing, and separate (not molded on) ladder and brake details.

The HO car's MSRP is \$24.95.

Figure 1: This ExactRail HO 50 ft. Hy-Cube boxcar represents a Trinity prototype built between August and December of 2004.

Figures 2, 3, and 4 (next page): Closeups showing the see-through end platforms, 100 ton trucks and full underbody details.

<http://www.exactrail.com>



Figure 2



Figure 3



Figure 4

# Tangent

# ACF 70-ton Gondola

## First Look

– by Jeff Shultz

**B**ased on the Pennsylvania RR G31B class, Tangent's third release is a 52-1/2 foot welded 70 ton car with drop ends of a prototype introduced in the early 1950s. Versions were also used by the Southern Pacific (G-70-12) and Wabash.

The PRR purchased over 11,000 of the G31 series (G31/G31A/G31B/G35) which means it's likely this car was commonly seen across the United States. They lasted in revenue service into the 1990s, and were also used by PRR successors Penn Central and Conrail, as well as purchased second hand by other lines.

Tangent's model features simulated wood floors, appropriate for the G31B. Some of the other classes in the G31 series had steel floors instead.

The model features Tangent's new 70-ton ASF A-3 Ride Control truck with metal wheels, coupler lift bars, air hoses, and Kadee scale couplers (#148s). The wire grabs and ladders are separate parts, as is the ratchet style brake and see-through

brake platform on the PRR model we received.

Brake lines and underframe parts are modeled in high-detail. The model includes tie down holes – which Tangent says are scale sized. We can say they'll give a needle a challenge when it comes to threading something through them, very fine wire might work best.

The first release includes three different paint schemes – the original 1951 PRR

Freight Car Red (24 road numbers), 1953 Southern Pacific Freight Car Red (12 road numbers), and the Wabash Railroad's original 1951 black scheme (6 road numbers).

Freight Car enthusiasts on the Modern Freight Car YahooGroup list (<http://groups.yahoo.com/group/MFCL/>) immediately identified several other possible paint jobs for both



**Figure 1: This model of a Pennsylvania RR G31B class car is Tangent's third release. This model represents the 52-1/2 foot welded 70 ton car with drop ends that was introduced in the early 1950s.**

<http://tangentscalemodels.com>

this car and very similar designs from Pullman-Standard, so we expect to see more roadnames and numbers in future releases of this model.

It's MSRP is \$28.95 for all decorated and the undecorated assembled models. The undecorated kit sells for \$24.95.

Prototype information on this gondola is available on the Tangent website at <http://tangentscalemodels.com>. 



Figures 2, 3, and 4: Closeups showing the 70 ton trucks, the see-through end platform and fine cross-section cut lever, and the full underbody details.





## About our layouts columnist



**Charlie Comstock** is our layouts editor and columnist.

[Click here](#) to learn more about Charlie.

*Charlie Comstock is ...*

## UP THE CREEK: Tunnel Liners

A regular report on the construction of a 1950s-something layout

 **Reader Feedback**   
(click here)

Avoid that “hollow hills” look. If someone peeks into a tunnel, will they see evidence of the solid rock the construction crews blasted through, or only empty space? In this column I explain how I handled this issue.

**H**ave you visited a layout with gorgeous scenery? You admire tall mountains, waterfalls, stands of tall timber, and track that snakes its way through the rugged terrain. Locomotives struggle to overcome steep grades while their trains cling to mountain sides, fly over chasms on spindly bridges and dive into tunnels blasted through solid granite.

Then you take a closer look as a train heads into a tunnel.

“Hey, there’s nothing in there besides some cardboard webbing, a few 1x2’s and some plaster! Isn’t that hillside supposed to be solid rock?”

The illusion is destroyed (or at least tarnished).





Figure 2

I didn't want this to happen to visitors (or my little train crew guys either!) on the Bear Creek and South Jackson, so I resolved that my tunnels would at least appear as though they were drilled through solid rock. Tunnels would have sides and tops to hide any unsightly hollowness.

I considered (briefly) making a hillside out of solid plaster then actually drilling a tunnel through it, but for obvious reasons I didn't do it. That left me seeking a means to line the tunnels.

So far, two of the three tunnels planned for the BC&SJ have been built. Tunnel 3 is quite short and I decided to model a blasted-rock interior for it. Tunnel 2 is a bit longer - perhaps 3' long - and I decided to model a timber framed interior for it. Although not a really long tunnel I was concerned about access to the track within the tunnel in the event of derailments. I elected to make the side of the tunnel liner closest to the aisle removable should the need for emergency access arise (after 4 years of service it hasn't been needed yet).

### **A Blasted-Rock Liner**

I looked at the Woodland Scenics plastic molds for casting tunnel liner segments. Needing to separately cast the right and left sides of the tunnel then connect them together at the top (as well as connecting multiple segments together) didn't appeal to me.

Joe Fugate illustrates this method of building tunnel liners in Vol4 - Scenery DVD ([model-trains-video.com](http://model-trains-video.com)).

**FIGURE 1:** (previous page) A pair of BC&SJ Alco RS-2 locos approach tunnel 3 heading west.

**FIGURE 2:** You can see some of the simulated rock in the tunnel 3 liner in this photo.

**FIGURE 3:** Testing tunnel portal clearance is VERY important!

I taped the tunnel portal and a backing plate in place above the track and ran my longest equipment through it, keeping an eagle eye on the clearances. When I was sure they were ok I marked the roadbed with where the tunnel openings would be.

**FIGURE 4:** I carved the form for the tunnel liner from rigid pink foam. I had to laminate 2 pieces to get the height I needed. I used a hot wire foam cutter and a long sanding block with 50-grit sandpaper wrapped around it to do the carving. Do the sanding outside, have an assistant standing by with a vacuum, or else prepare to be covered with pink sawdust!

I'd been roughing-in scenery using cheesecloth stretched over cardboard mesh which I then painted with several coats of watery plaster. I decided to try a modification of this technique for tunnel 3. Follow along and I'll show you how.

### **Checking clearances**

The first step was to see where the tunnel would go, how long it would be, and perform preliminary clearance checking. I didn't want to have a beau-



Figure 3



Figure 4

tifully detailed tunnel interior my trains couldn't get through!

I erected a temporary portal backing using masking tape to hold it in place (FIGURE 3) and set the Chooch portal in front of it. Then I ran my longest equipment through the portal to ensure there would not be a clearance problem.

### **Carving a tunnel form**

Once I knew about where the tunnel portals would go I carved a chunk of

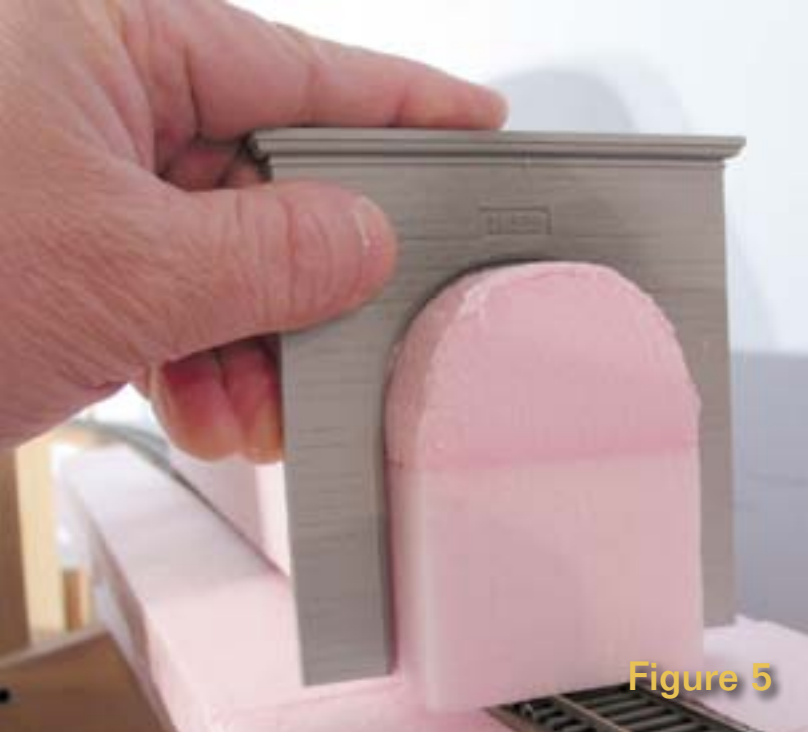

Figure 5



Figure 6

pink foam to represent the shape of the tunnel interior (Figures 4 and 5). I put the tunnel form on the track to further eyeball how it would all fit together (Figure 6).

### Modeling blasted-rock

I crumpled up some aluminum foil and carefully draped it over the tunnel liner form (Figure 7). After this I painted on several coats of very runny plaster, allowing a few hours between each application (Figure 8).

I cut some cheesecloth roughly to size and taped it in place over the tun-

**FIGURE 5:** I used the tunnel portals I'd selected as templates to check the liner form for size as I carved.

**FIGURE 6:** I deliberately made the liner form longer than needed. I set it in place on the track to help visualize where the portals would go. Having the fascia already in place made this easier.

nel liner assembly (Figure 9). Then I painted several more layers of plaster over the cheesecloth. The cheesecloth acts like rebar, giving the plaster extra strength. When I viewed the tunnel liner assembly from the end, the cheesecloth/plaster looked a little like the Greek letter Omega OMEGA (Figure 10). I wanted flanges on either side of the liner to make mounting it easier (it would be hard to glue to an edge).

Once the plaster had set overnight I carefully slid the tunnel liner form out and peeled the aluminum foil off the inside of the liner. I used some cheap, flat-black spray paint to change the tunnel liner's color from blinding white to something suitably dark for the inside of a tunnel.

### Trimming

I trimmed off most of the protruding cheesecloth then took the rough tunnel liner over to the layout and set it in place on some pink foam I'd hot-glued to the sides of my masonite spline roadbed. I was lucky enough that it all fit pretty well. I propped the tunnel portals in place and stepped back to check it out (Figure 12a,b).



Figure 7

**FIGURE 7:** I elected to use crumpled aluminum foil wrapped over the form to simulate the blasted-rock tunnel interior. This doesn't make terribly realistic rocks but since it will be inside a dark tunnel I figured it would be ok.



Figure 8

**FIGURE 8:** With the crumpled aluminum foil in place I painted on layers of very thin (lots of water) plaster. After several coats the form looked like this. **DON'T** use a good brush to apply the plaster and be sure to clean it after every coat. I let each coat set for 30 or more minutes before adding a new one. Mist the previous plaster layers with water before adding each new coat. I added a bit of tempera powder to the plaster to kill the stark white color. Wax paper under everything keeps it from sticking to the work surface.





Figure 9

**FIGURE 9:** After I'd painted 4 coats of plaster on the aluminum foil, I cut some cheesecloth to size and draped it over the form leaving a generous amount beyond the ends and sides. I used masking tape to temporarily fix it in place before painting the top with the thin plaster. Once that set, I removed the tape and painted a complete coat of plaster over the form.



Figure 10



Figure 11

**FIGURE 11:** This is what I saw with the form removed and foil peeled away. I zapped the inside of the tunnel with some cheap flat black spray paint and presto! It started looking a lot like the inside of a tunnel.

I carefully marked the ends of the tunnel liner where I wanted the portals to be and went over to my band saw where I cut the liner's ends off (yeah I know, plaster isn't good for a saw blade but I don't do this very often and it works great - a hack saw would've been my alternative).

**FIGURE 10:** The layers - innermost is the pink foam form, then the cumpled aluminum foil, a layer of plaster, and cheese cloth rebar with the outer plaster layer.

**After the plaster had set for a day I slid the pink foam form out and peeled away the aluminum foil.**

## Portal Mounting

I elected to use Chooch cast-resin portals. I made mounting plates from 1" pink foam by tracing the tunnel portal outline on the foam then carefully cutting out the tunnel opening. I gently sanded the tunnel opening and smeared drywall compound on it to make it more like the tunnel portals.

Before gluing the tunnel liner in place, remember to paint the roadbed and make mounting plates. I made mounting plates for tunnel 3 from pink foam. I'll glue these to the liner and the "ground" providing a flat, vertical mounting surface for the portals (I attach my Chooch tunnel portals with bits of masking tape so they're easily removable - a good



Figure 12 a

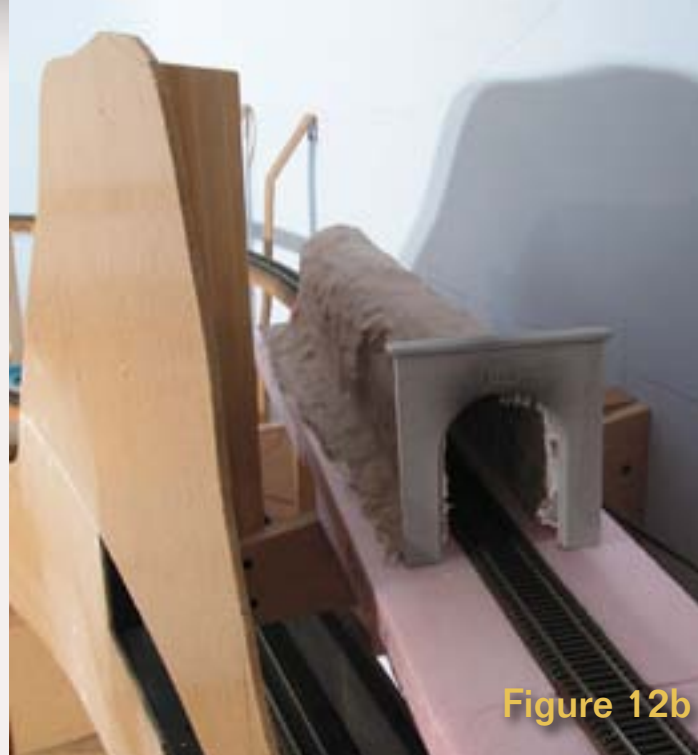

Figure 12b

FIGURES 12a and b: I cut off the raggedy ends of the cheese cloth and set the tunnel liner in place to see how it would look. I also checked clearances again by running a train through (you can't do too much clearance checking!) You can see the mounting flanges in the picture on the right. When it's completely ready I'll glue the liner in place on the (pink) ground using latex construction adhesive.

FIGURE 13: I made mounting plates for the portals from 1" thick pink foam. These provide a vertical surface for the external portals to attach and I can bring scenery up to them while the real portal is safely tucked away in a place without plaster or paint splashes.



Figure 13



Figure 14

FIGURE 14: I remembered to paint the track and add ballast before gluing the tunnel liner in place. It's amazing how our instinct to 'get finished' sometimes lets us forget important steps!

With everything in place I ran a final clearance-checking train through the tunnel before glueing the liner and mounting plates in place with construction adhesive. Use slow setting glue - you'll want lots of working time!

thing when making scenery mess nearby). I could also easily tape over the tunnel opening to keep crud out of the tunnel while working on the rock faces adjacent to the tunnel.

The pink foam was a gamble - the stuff is easy to work with but it's awfully soft and could be nicked rather easily. I smeared spackle (drywall mud) inside the portal opening to smooth out the texture of the foam - if you cut the foam with a hot-wire cutter this step might not be necessary. Once the spackle was dry, I painted the pink

foam mounting plates the same concrete color I planned for the portals.

### Final Installation

I glued the tunnel liner and portals in place with latex construction adhesive. **DON'T USE A QUICK SETTING GLUE HERE.** I spent a LOT of time checking alignment. Then I ran my clearance-test consist back and forth through the tunnel to make sure it would fit without hitting anything (or coming uncomfortably close to hitting anything)!



Figure 14

FIGURE 14: The west portal of tunnel 3 after liner and portal installation and with rough scenery contours. Figure 1 shows this scene after scenery was contoured.

FIGURE 15: The east portal of tunnel 2 showing the timbered tunnel liner.



Figure 15



The Bear Creek Hauler West passing through tunnel 3 on the authors layout.

Oh yeah, if you want the track in the tunnel to be ballasted, do the ballasting and double check operation of trains on that track BEFORE gluing the tunnel liner and mounting plates in place!

Presto! A tunnel for your miniature train crews to run through, with them never dreaming that the rocks surrounding them are hollow!

## A Timber-Framed Liner

I wanted timber framing inside tunnel 2 (Figure 15). This type of liner was extremely simple to make. I cut out some pieces of unwarped plywood the length of the tunnel and as wide as the roof of the tunnel would be. Then I ripped some scrap lumber to the size of the timber framing in the tunnel (you could use commercial stripwood if you'd rather but that can get a bit pricey and hardly anyone is going to

see these timbers once the liner is installed).

I glued the timbers to the plywood sides of the tunnel liner spacing them about 3/4" apart (since they're cosmetic rather than structural; use whatever spacing you like here).

Another piece of plywood made a roof for the tunnel (I didn't bother trying to model a curved or slanted tunnel roof). I used cheap black spray paint to color the inside of the tunnel.

## Accessibility

Tunnel 2 is long enough to make me worry about equipment getting wedged inside, jammed between the timber posts, and just out of reach of my 12"-to-the-foot hands and arms. My solution was to make the aisle side wall of the tunnel removable! I added a couple

*Continued on page 133 ...*

## Emergency Access!

I was talking with Horace Fithers the other day and he wanted to know about the emergency access plan for tunnels 2 and 3.

Tunnel 3 is so short, about 18", it shouldn't be a problem. However, tunnel 2 is nearly 3' long. If something were to derail and get wedged inside it would be a BIG problem. Fortunately when I built it, I'd provided a removable wall in it's side. I'd also made the fascia adjacent to the tunnel removable (Figures 16a, 16b).

So far I've not had to use this but if worse comes to worst, I can enter what Horace calls *The Hall of the Mountain King* (apologies to Edvard Grieg), remove the side of the tunnel, and rescue people and equipment from internment.

Other methods of providing access inside long tunnels:

- Line only the first 12" of the tunnel - after that, trains run through hollow hills, providing access from behind or underneath.
- Make pieces of the liner completely removable from behind or underneath.

Much better than trying to reach in with tongs and fish stuff out.

## A clipping from the *South Jackson Gazette* ...

### Journey to the Center of the Earth Proposed!

Citizens living near the Bear Creek & South Jackson tracks in the Plaster Peak mountains are abuzz with the news that the mountains surrounding them may actually be hollow!

Explained Horace Fithers, a more than slightly vocal local, "Well, it were like this. A crew of them arbor-realistis were out on an expedition to augment the vegetation above tunnel 3 seein' how it's a touch sparse like up there. They was digging a hole for a new tree when a shovel one of 'em was using just kind of disappeared right down through the hole! Now that 'taint quite normal seeing as most holes got bottoms attached to them so it sorta set a bunch of us to thinking, could it be that they'd dug all the way through to the other side of the world?"

Chimed in Abe Euhnett, hoghead for the BC&SJ, "I've been getting kind of used to the idea of all these rocks being pretty solid when I drive trains through the tunnels and along those nice new cliff faces. I sure wouldn't be happy knowing that the mountains here aren't entirely solid."

Gaston Aridelyte, local chef was making suggestions that for once didn't involve aliens. "What" he

said, "if the ground were like the layers in a cake? If some gaseations got trapped between a relatively thin top layer and the more solid bottom layers it would just inflate that space like a baloon! Then once the rocks had set in their new position they'd be able to hold themselves up after the gaseations had bled away leaving behind a large open space."

Gaston's suggestion wasn't greeted warmly by some. 'Balloon Rocks are Balloon Juice' was a phrase overheard by this reporter - but how else could these formations have occured?

Expert spelunkers have converged on the area to investigate. This reporter arrived to interview them as they were making their preparations.

Team leader Neil Ankraulan spoke, "We're totally excited to be here! The discovery of a new and extensive system of caverns is like really cool. We can't wait to get in there and see what natural beauty is present. Frankly we're hoping to be able to make contact with some troglodytes - maybe we can bring a couple back with us! There even may be an



Is the hillside around tunnel 3 really solid rock?

entire ancient civilization in its unspoiled original state down there!"

In an unrelated incident a resident of Redland (who wished to remain unnamed) told of a freak rain storm in which the precipitation included small farm implements as well as the more usual rain drops. As evidence he held out a small and rather battered shovel he claimed had fallen out of the sky in broad daylight. Redland is located along the tracks of the Bear Creek and South Jackson railroad in what the locals refer to as "the Land-Down-Under".

This reporter certainly hopes the solidity of the trackside moutains can be quickly established. ❖

\* If you like the South Jackson Gazette, you can read more at [bcsjrr.com](http://bcsjrr.com).



Figure 16a



Figure 16b

FIGURES 16 a,b: An emergency access hatch in the side of the fascia. Part of the tunnel 3 liner can be flipped up to allow retrieval of any trains that may derail or run amok and get stuck.

of flat head wood screws to the back of the removable tunnel liner pieces to act as handles (Figures 16a,b).

When I glued the liner in place I made sure I got no glue on the removable sections.

I again used Chooch portals on tunnel 2 and made portal mounting plates for them from pink foam in the same manner as I made the mounts for the tunnel 3 portals.

Once the portals are in place it's very hard to see that the roof of the tunnel isn't curved - this isn't visible just by peering through a portal.

## Summary

The tunnel liners have made the scenery on the layout look just a bit more believable (and all the miniature folks trackside seem to really like 'em too - Horace told me so). We've all seen pretty pictures of model trains rolling through magnificent scenery. Skillful construction (and photography) can leave us thinking the scene we're viewing is real. But is the beauty of our models more than surface deep?

# The Model Railcast Show

Keeping you on the **RIGHT TRACK!**

**Click here to learn more ...**

Ryan & Tim at Hartford 2009  
**(Show hosts)**



## About our N-scale columnist



**John Drye** is our N scale editor and columnist.

[Click here](#) to learn more about John.

# COMME-N-TARY: Three by Six; the New Four by Eight?

Modeling in the hobby's most eNgaging scale



## 3 x 6 is a size worth considering – here's some ideas for small N Scale Layouts ...

For years, the “standard” beginner Model Railroad Layout was a 4 x 8 sheet of plywood with an HO Scale oval layout.

This made pretty good sense. Plywood sheet was readily available, HO trains were affordable and reliable, and 32 square feet (with some imagination) provided room for plenty of railroad-ing. Many trackplans were published over the years for this space and hundreds upon hundreds of such layouts built, providing an introduction to our great hobby for many.

N Scale provides an alternative to the classic 4 x 8 design. Since 1/160 (N Scale) is about half of 1/87 (HO Scale), 54 percent to be precise, a logical conclusion would be to use a 2 x 4 sheet of plywood and reduce everything by half.

However, 54 percent does not equal one half and plywood still comes in 4



**FIGURE 1:** The small RJ Corman yard in Cresson is an example of prototype inspiration for layout designs.

x 8 sheets. A few cuts though, and a 4 x 8 sheet of ½” plywood can produce a framed 3 x 6 layout, ready for track (Figure 2 next page).

## “The 3 x 6 is more portable and fits into a smaller space—including most bedrooms.”

The smaller size, both layout scale and frame does have some advantages. The 3 x 6 is more portable and fits into a smaller space—including most bedrooms. The 3 x 6 also provides a bit more room for larger curves and longer sidings.

### Layout Ideas

So, just how much model railroad fits onto our 3 x 6 layout? Four examples are described in this column, varying in theme, location, era, and complexity. They all provide a loop for continuous running for breaking in locomotives or for display. The plans also allow for a variety of RR operations, providing the modeler and a few friends the opportunity to enjoy the complete spectrum of model railroading activity.

### Layout #1: Lafayette Western

The Lafayette Western represents part of a medium-sized Midwestern Railroad in the 60s or 70s. Lafayette is

a small town roughly in the middle of a single-track division of the railroad (Figure 3).

The town's industries generate sufficient traffic to warrant a dedicated switcher, probably a first-generation road switcher such as a GP-7 or RS-3. The industries are typical of those found from Ohio to Iowa: a couple of grain elevators and a soy bean processing plant, and a team track to handle delivery of farm implements and other merchandise.

The layout is divided into two areas. The first is Lafayette itself, including the industries, a brick station no longer served by passenger trains, and a few stores representing the town.

A low ridge separates Lafayette from Wabash Junction, a long passing track that serves as staging. WJ includes only a shed for railroad equipment and supplies, accessed by a dirt road.

**“After each freight passes through town, the switcher sorts and spots the new arrivals.”**

The rolling terrain and ridge are covered with trees, further helping to divide the two scenes. Cuts allow the railroad to pass through the ridge and a small stream allows for bridges or culverts for scenic interest.

This plan allows for interesting operations. At the start of a session, the switcher gathers outbound cars from the plant and elevators, and spots them on the eastbound and westbound yard tracks.

Two through trains, one in each direction, are set up at Wabash Junction. Perhaps headed up by a pair of F units or second-generation geeps, these manifest freights will pick up the

outbounds and set out cars, including empties for the elevators, supplies for the plant and assorted deliveries to the team track.

After each freight passes through town, the switcher sorts and spots the new arrivals. A simple car card system could be used to keep the conductor organized.

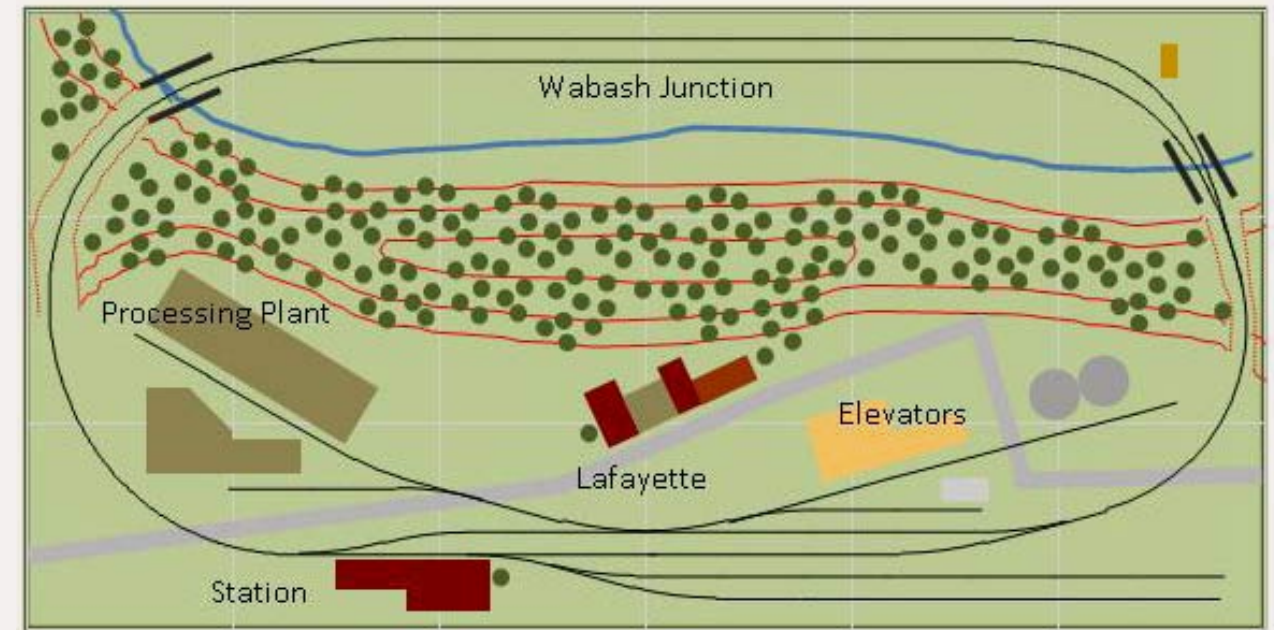

**Lafayette Western**

**FIGURE 3: The Lafayette Western models part of a 1960s-era mid-sized Class I midwestern road.**

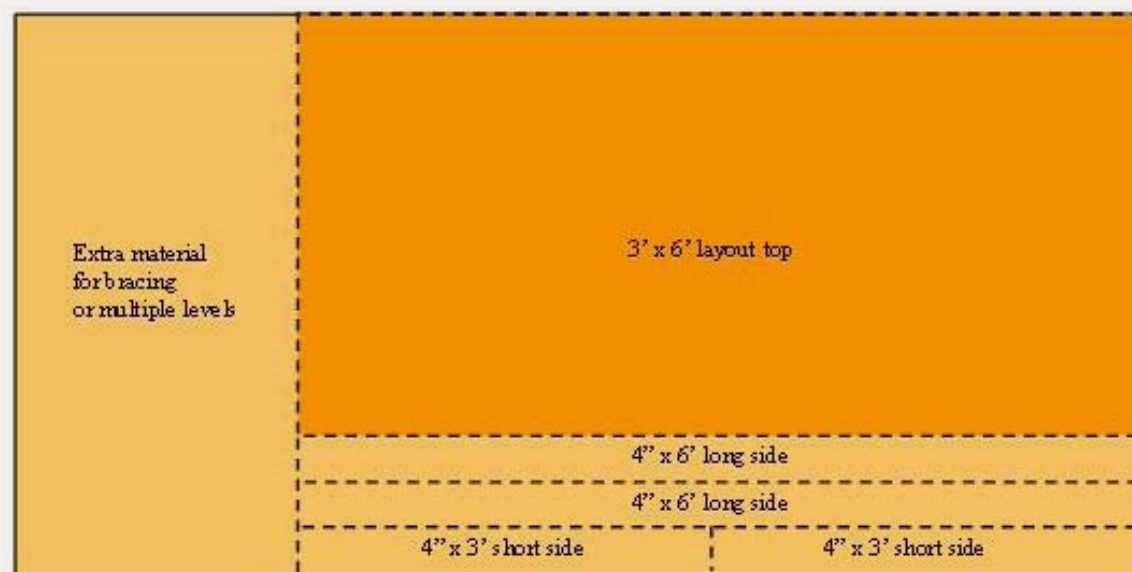

**FIGURE 2: Plywood cutting diagram.**

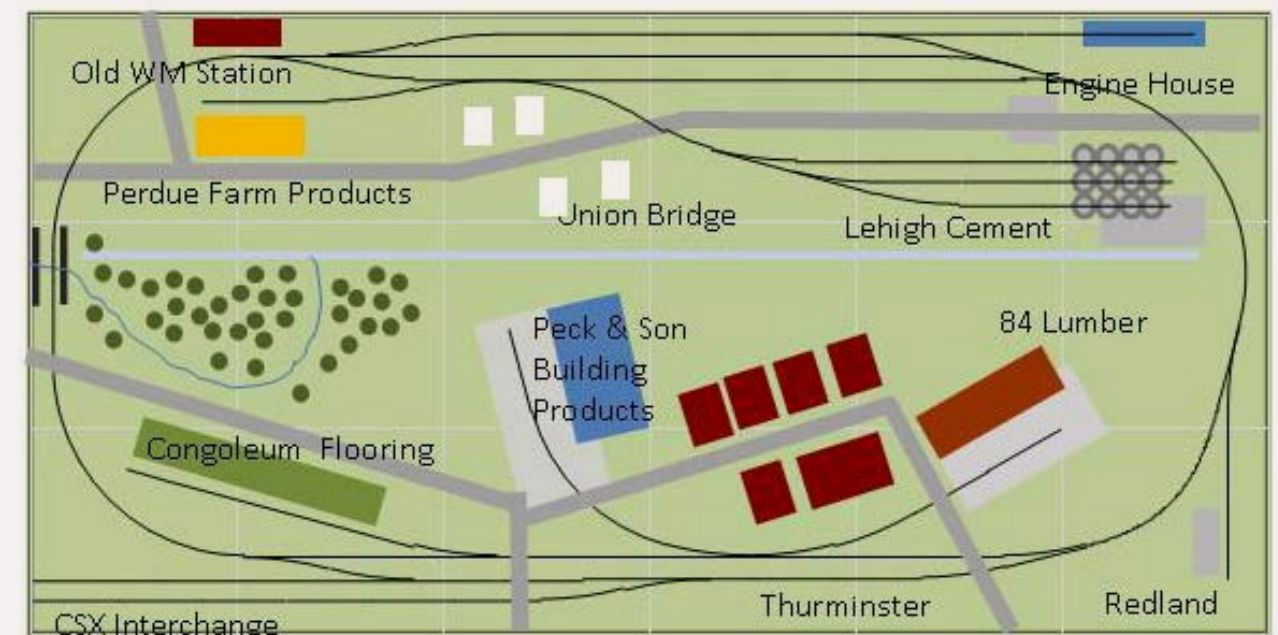

**Maryland Central**

**FIGURE 4: The Maryland Central is inspired by a successful modern-day short line.**

The structures on the layout all can be represented with readily-available kits. There are many choices for the grain elevators, varying from wood to concrete to metal for the silos. The station, railroad structures, and town buildings are also available from a variety of manufacturers. The soybean processing facility is a candidate for modular construction, using any of the components available. Grain hoppers to spot at the elevators, along with box and tank cars for the plant, are also easy to come by.

When the owner gets tired of operations, or wants to show off the layout to visitors, the loop allows for continuous running and a bit of railfanning.

## **Layout #2: Maryland Central**

The Maryland Central is loosely based on a modern day short line. The prototype Maryland Midland operates on former Western Maryland trackage west of Baltimore. Like the prototype, the MC uses four axle geeps to serve one large and several small industries, interchanging with CSX at the end of the line (Figure 4 previous page).

This layout incorporates several elements from the prototype, but shuffles them around considerably to fit the space. The largest industry is the Lehigh Cement plant in Union Bridge, MD, the railroad's headquarters. Other elements include the Redland Brick plant west of Union Bridge and a fictional location representing several towns along the line.

The CSX interchange tracks are physically located on this part of the layout as well, but a little modeler's license allows us to operate as though they are at the other end of the line.

The layout is divided by a partial backdrop, one end disguised by the cement plant and the other by a bridge and wooded ridge.

The backdrop separates the two locations and makes the layout appear larger. It could use commercial photographs or painted-on images of wooded ridgelines. The backdrop only needs to be tall enough to hide the structures on the opposite side.

**“This layout incorporates several elements from the prototype, but shuffles them around considerably to fit the space.”**

The cement plant is represented by a stack of silos in Union Bridge covering three loading tracks. The plant could be built from PVC pipe with details from one of the kits representing the aggregate or gravel industry.

A small feed store is also located in town. The Redland Brick plant is served by a siding between Union Bridge and the town of Thurminster,

represented as on the prototype by a loading dock a few hundred yards away from the plant itself.

Thurminster incorporates elements from several locations on the railroad. 84 Lumber and Peck & Son

Construction Products both receive building products in center-beam flat-cars and boxcars. Congoleum Flooring receives chemicals in black tank cars. These structures can all be built using

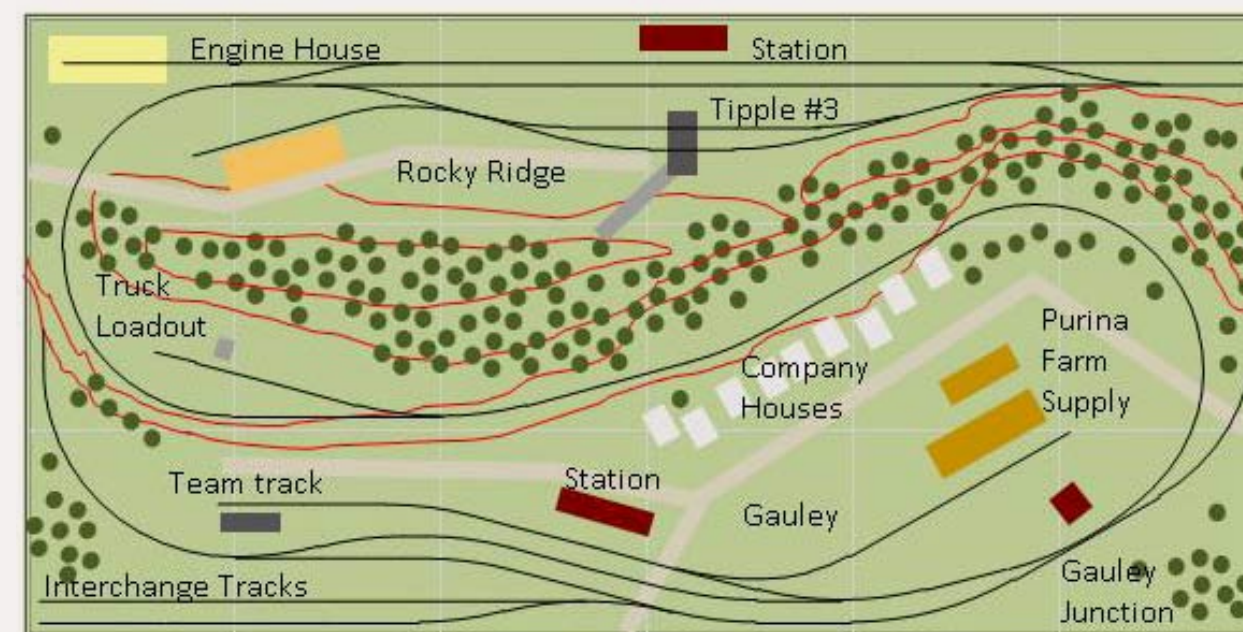

**Gauley & Eastern  
(Upper Level)**

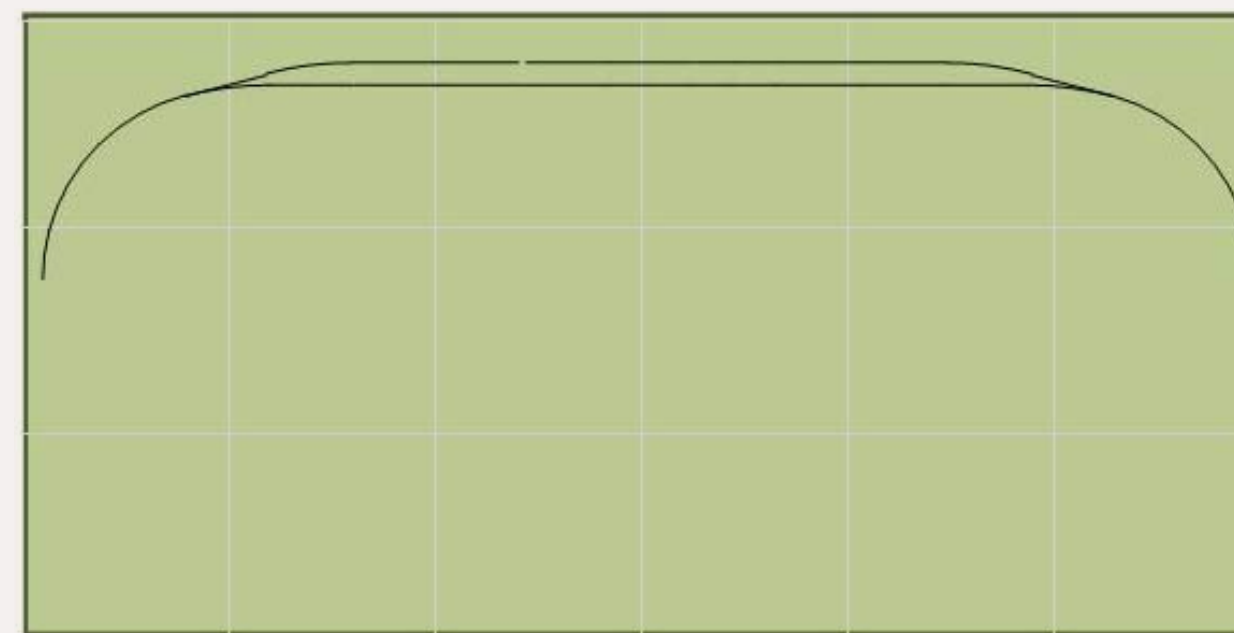

**Gauley & Eastern  
(Lower Level)**

**FIGURE 5: The two-level Gauley and Eastern represents a struggling 1930s coal hauler.**



modern industrial kits. Sticking to 50- or 60-foot cars will make it a little easier to manage the curves, and there are plenty of suitable models available.

The main function of the railroad is to deliver Lehigh Cement in its own and borrowed two-bay hoppers to the CSX for delivery to customers across the country. Operations consist of collecting cars from the silos and making up a train to deliver to the interchange. Loaded hoppers are exchanged for empties and for cars destined for deliveries to other industries on the layout. The trailing-point siding for Redland Brick is switched on the trip back to Union Bridge.

Once back in Union Bridge, cars are sorted for delivery to the cement plant and for the train to Thurminster. While the first train is delivering empty cement hoppers, a second train travels around the other end of the layout to serve the customers in Thurminster. Between sessions, loads on the flatcars delivered to the building supply customers can be transferred to the empties on the interchange tracks.

There is sufficient operating interest here to keep a small crew occupied for several hours, and the Maryland scenery provides a great place to display and run trains.

### **Layout #3: Gauley & Eastern**

Incentive for the design of the Gauley & Eastern was provided by the release of good-looking, great-running steam

locomotives in N Scale. These include a Mikado by Kato, the Atlas Shay, Bachman's 2-8-0, and other examples of US prototype steam. The track plan (Figure 5, previous page) is inspired by standard and narrow gauge coal-haulers such as the East Broad Top and Buffalo Creek and Gauley.

The layout represents a struggling short line connecting with a Class I Railroad somewhere in the coal fields of the Appalachians. The era is the 30s, so the railroad provides both freight and passenger service.

The Class I C&O is represented by a lower-level loop that provides staging for a pair of through freights. The G&E connects with the C&O at the front of the layout using a pair of interchange tracks. The line climbs to the mines on the upper level by departing the mainline at Gauley Junction on the right side of the layout and then swinging back to the left before looping around the end of the layout. The grade is 4%, so trains will be short. There is a truck load out serving local mines along the way.

The tipple at Rocky Ridge keeps the railroad solvent. In addition to hauling coal down the hill to the C&O, the railroad still carries the miners to and from work each day. Trains on the layout roughly follow the EBT's 1940-era schedule, using Shays instead of narrow gauge 2-8-2's. Coal is hauled in two-bay hoppers with passengers riding in an old combine or sometimes in the caboose.

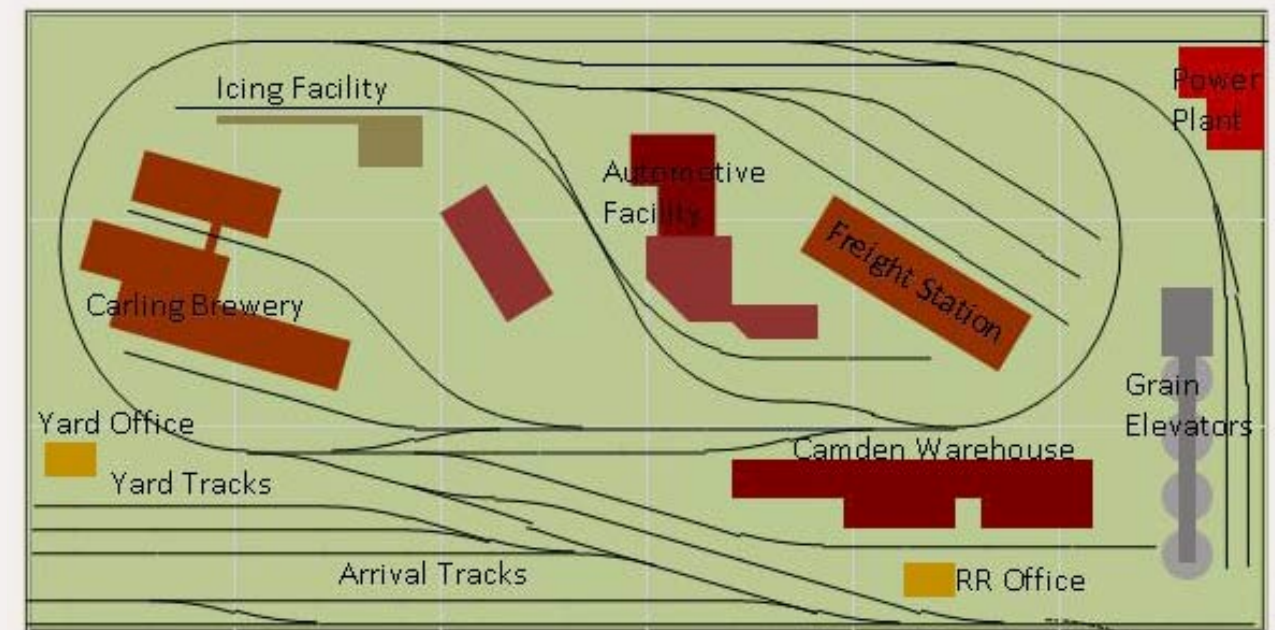

**Canton Industrial**

Optional  
Staging  
Extension

**FIGURE 6: The Canton Industrial would allow ample opportunities for switching.**

Ready-to-run steel two-bay hoppers are available from several manufacturers in a variety of styles. Most of the other rolling stock will be wood boxcars or gondolas that are now becoming available in early 20th century paint schemes. One of the "Old Time" (wooden) passenger car sets can provide a coach and a combine – all the passenger equipment the railroad needs.

The first train of the day departs before dawn and hauls the last loads from the previous day's work from Rocky Ridge to Gauley and returns with a coach full of miners and any empties the C&O has left in the yard. Shay #16 shuffles hoppers at the mine and makes up a mid-day train to return back to Gauley.

While #16 is working in Rocky Ridge, the roads other locomotive, Shay #17, works the team track and farm supply store in Gauley and then heads uphill with more empties after the C&O drops them off. At the end of the working day, the miners head downhill with the results of their work.

Although small in size, the G&E represents all of the trackage of this fictional short line. It is an opportunity to fill a small space with craftsman kits and all the character of the 30's.

### **Layout #4: Canton Industrial**

This urban-themed layout is designed to represent big-city industry trackage from the 1950s. The name comes from a railroad that was founded in 1906 and still serves downtown

Baltimore. It is a perfect location to use the excellent small switch engines now available in N Scale (Figure 6).

Big-city railroads feature tight curves, street trackage, interference from vehicle traffic and a variety of industries. The Canton includes a brewery, an icing dock, an automobile part fabricator (axles for GMC trucks) a large freight station, grain silos, power plant and a warehouse.

The prototype received cars from the B&O, PRR, and other railroads, then sorted them for delivery to the appropriate customer. The CI represents this process with an arrival track and small yard. An option is shown that extends the "big" railroad off the 3 x 6 portion of the layout to a staging area that could run along a wall.

The layout could support up to three crews. The first crew sorts arriving cars by location, using the arrival tracks and yard. The layout could be divided into a north and south district each served by its own train.

The north and south turns each serve the industries in their respective locations, using the run-around tracks to get cars to the correct destination. The complex trackage and tight curves will make this a challenging and interesting operation.

Several of the industries are large enough to have several spots for receiving cars. The brewery has arrival tracks for grain and hops (still handled in boxcars) and shipping tracks

for reefers. The reefers will need to be iced prior to delivery. The freight station includes three tracks for less-than-carload shipments. Movement of cars will need to be coordinated with the station agent. Other industries, while compressed from the prototype, still can support dozens of car movements in each operating session.

Several of the layout industries can be built or kitbashed from readily-available structures. These include the freight station (a great candidate for an easy stretch using two kits), the icing platform, power plant, grain elevators and RR structures. The warehouse is also a good candidate for a doubled kit. Both the brewery and automotive plant can be built using modular construction.

The CI is the most complex of these 3 x 6 designs and will require careful construction to ensure reliable operations. The railroad provides an opportunity for the structure builder to display a variety of kitbashed and scratchbuilt industries and would be an impressive display of 19th and 20th century architecture and urban canyons.

These designs show the variety of layouts that can be achieved in a 3 x 6 space. Any of them could be shifted in era or geographic location to fit your favorite prototype. The 3 x 6 offers plenty of modeling enjoyment to suit the owner and its size makes it easy to set up, move and store.

ON THE AIR

Scotty  
Mason  
Live!

**The studio is ready.  
The cameras are rolling.**

**No editing. No re-takes.  
Working "without a net" ...**

**100% Model Railroading  
content, completely live  
and unrehearsed.**

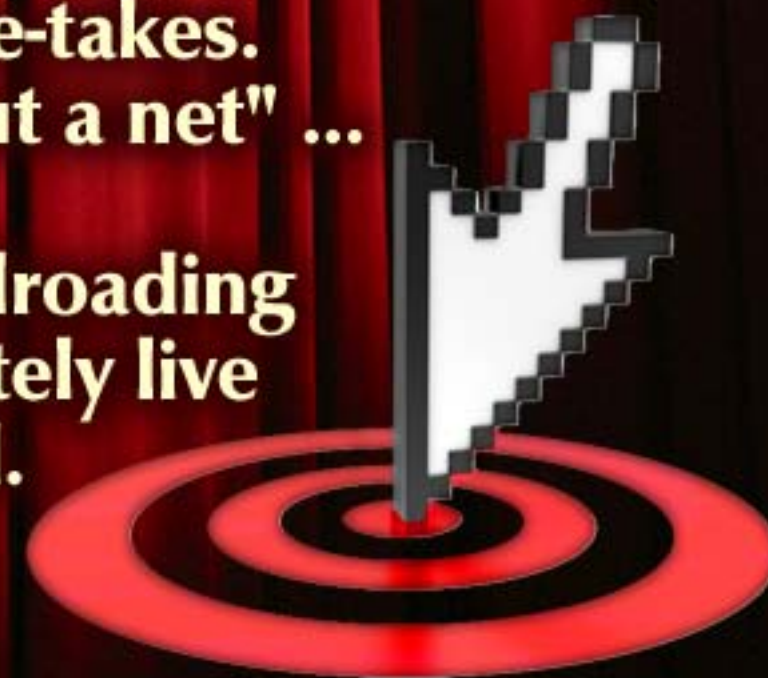

click to learn more

About our  
new media modeling  
columnist



Ryan Andersen is our resident new-media technology expert.

[Click here](#) to learn more about Ryan.

## NEW MEDIA MODELER: Photography – New or Old Media? Model Railroading in the Internet Age



Have you ever wondered where you can find training and tips for photography on the web?

On a recent show (ModelRailcast.com, show #91), Marty McGuirk and I interviewed Dave Frary. One of the topics brought up was how Dave got started in photography. We discussed some of the issues Dave deals with when doing a photo shoot of a layout.

As I look back on that conversation with Dave and I notice how photography, and video for that matter, has not changed all that much over the years. Yes, they both have been digitized and workflows streamlined with computers, but the basics are all still there and they're still just as important.

For instance, Dave mentioned that lighting was his number one challenge when shooting a layout. This was no surprise to me; getting enough light has been a challenge me for me as well. Furthermore, as I continue

reading up on photography and video, I am constantly reminded to ensure that my subject has ample and proper lighting. Making sure that your camera's flash is turned on is not what they mean by good lighting!

So what does taking pictures or shooting video have to do with new media?

*Everything.*

Like this magazine – YouTube, Flickr, Facebook and many other websites' most compelling content is the photos and videos. And this content comes from people like us.

Now I am no photography or video expert, by any means. I'm merely trying to do my best when shooting photos or videos for my podcast.

But many (if not all) of the things we've learned over the years of shooting photos remain as important as they did *before* the modern era digitized our lives. If you want to create nice looking photos or videos of you layout to share with the world, make sure you have enough light on your subject.

Beyond lighting, there is a world of things to learn about, but don't overwhelm yourself. Start small and work



FIGURE 1: DIY Photography has some great tips for beginners.

your way up. There are a ton of photography and video self-help related websites out there. The following are some good websites I have found to be helpful in my journey to creating better, more crisp and more engaging photos and videos.

## Helpful Websites

**DIY Photography** (<http://www.diyphotography.net/>) – This site has some great tips for someone just getting started in photography or just looking for some neat-o and cheap ideas to get good results from your photo shoots (Figure 1, previous page).

For example, here is a cool tip on how to create your own flash mounted diffuser: <http://www.diyphotography.net/homestudio/cheap-diy-flash-mounted-softbox>. For more,

here is a list of recent posts on DIY Photography: <http://www.diyphotography.net/tracker>.

**Life Hacker** (<http://lifehacker.com/>) – Now here is a site you might not stumble upon, but is a great site for all kinds of life and productivity tips.

I frequent this site many times a month checking out their new posts. While I was there one day, I found a link to an older post on tips for shooting video like a pro, check it out: <http://lifehacker.com/214043/8-ways-to-shoot-video-like-a-pro>. Note that point 4 is all about lighting!

**Photo Focus** (<http://photofocus.com/>) – Photo Focus is not only a photography blog, it's also a podcast. That's right, you can download and listen

**“So what does taking pictures or shooting video have to do with new media? Everything. Like this magazine – YouTube, Flickr, Facebook and many other websites’ most compelling content is the photos and videos. And this content comes from people like us ...”**



FIGURE 2: You might miss this site in a search, but it's loaded with photo tips.

to Photofocus from iTunes for free at your leisure.

Although focused more towards the amateur and professional photographer, I find the show and tips very helpful. Scott Bourne and his guests talk about the latest in photography and back it up with tips and inspirational do-it-yourself projects. Scott also has a tendency to give stuff away, so you might get lucky!

**Matt Cole** (<http://www.uscoles.com/technical.html>) – If you have wondered what f-stop (a.k.a. aperture) means, how to choose the right shutter speed, or how these two differ from one another, then you should check out this site.

I found Matt's website during a google search about a year ago. This site mainly covers topics on photography. Of particular interest to a

new photographer is Matt's technical page. He explains shutter speed and aperture settings in some detail. He also covers what they mean and how to set them properly.

**Photo Secrets** (<http://www.photosecrets.com/>) – For another take on f-Stop, aperture and other camera setting, plus some great tips, check out <http://www.photosecrets.com/tips.p09.html>. This site has a boat load of photography related tips for us newbies.

And last we come full circle, back to lighting. Here's an article I found on **About.com** covering how to better use the light meter on your camera: <http://photography.about.com/od/takingpictures/tp/photographylighting.htm>.

Photography is a huge field, but I hope these websites help some of the newbie photographers out there get stills and video you can be proud of.

Until next time, listen for more great tips on the Model Railcast Show. 



FIGURE 4: Photofocus is not only a blog, it's also a podcast.



FIGURE 3: For details of f-stop and shutter speed, Matt's Photo Guide is great.



FIGURE 5: Photoscrets has a boat load of tips for newbies.

# REVERSE RUNNING: Time Out! Bigger isn't always Better ...

Stepping outside the box with a contrary view



— by Joe Fugate

**T**rying to figure out how to make that large dream layout a reality? Hold it! Time out!

The key to a more satisfying hobby is not necessarily going larger. Smaller may actually be *better*.

It's that age old question – which is better, *quality* or *quantity*?

The main reason model railroaders think bigger is better is because they believe *quantity of run* automatically yields a more satisfying layout.

*Quality of run* actually outweighs quantity of run. Once you have some hobby experience, you realize a small layout with a high quality of run is far more satisfying than a large layout with a mediocre quality of run.

Quality of run depends on:

- Interesting trains
- Rare derailments
- Realistic speeds
- Detailed right-of-way
- Realistic looking locos
- Realistic rolling stock
- Nice scenery

**Interesting trains:** Lots of generic trains don't do anything to increase quality of run. A few trains with a well-defined purpose: "the logger", "fruit express", "daily commuter" add more to the layout than a horde of generic trains.

**Rare derailments:** Lots of turnouts and equipment means more stuff to be debugged and tuned. Which would you enjoy more: a 4 hour op session on a small layout that had nary a single derailment, or a 20 minute run on a large layout that had a derailment every minute or two?

**Realistic slow speeds:** Which would you enjoy more – running on a small layout with two locos that crawl along smooth as silk at slow speeds – or running dozens of locos on a large layout where everything runs like a jackrabbit?

**Detailed right of way:** When running trains, you spend much of your time looking at the track, so the better detailed your right-of-way, the more visual fun running the trains. The larger the layout, the more right-of-way you have to detail – so on a large layout it's very tempting to just run trains for a long time on unballasted flex track that's on bare roadbed.

On a small layout, there's less track to detail, and you can take more time really detailing the right-of-way to a high degree of realism – and get a much higher quality of run!

**Realistic locos and rolling stock:** Things you notice at a glance, like realistic weathering, count the most here. Trains in motion don't allow you to study the details very closely, so having the right number of louvers isn't as important as you might think!

Which would you rather run trains on – a small layout where everything is realistically weathered, or a larger layout where most equipment looks like it's straight off the shelf – shiny and stark, with little weathering and some of the details are still just unpainted black plastic?

**Nice scenery:** This one comes last because when running trains you don't spend much time just looking around – you focus on the trains. Many have

reported a great time operating on layouts with little scenery. If quality of run is high, then it's true, having much scenery isn't a requirement!

**Conclusion:** Which of these two layouts would you enjoy more:

## LAYOUT A

- small layout
- interesting trains
- zero derailments
- weathered locos and equipment
- nicely ballasted and weatherd right of way
- minimal scenery yet

## LAYOUT B

- large layout
- fully scenicked
- ballasted track with shiny rail sides
- proper equipment, fresh out of the box with no weathering
- trains are all generic
- things derail a lot

Most will say without hesitation: Layout A.

I rest my case.

Clickable Advertiser Index	Page
<a href="#">Accu-Lites</a> .....	16
<a href="#">Berrett Hill Trains</a> .....	13
<a href="#">BLMA</a> .....	3
<a href="#">BPL Brassworks</a> .....	10
<a href="#">Canyon Creek Scenics</a> .....	28
<a href="#">CMT</a> .....	6
<a href="#">DCC Installed</a> .....	17
<a href="#">Digitrax</a> .....	9
<a href="#">Fast Tracks</a> .....	4
<a href="#">Litchfield Station</a> .....	12
<a href="#">LBH Custom Model Railroads</a> .....	13
<a href="#">Micro-Mark</a> .....	15
<a href="#">Model Railcast Show</a> .....	133
<a href="#">Model Railroad Tips</a> .....	13
<a href="#">Model Trains Video (1)</a> .....	5
<a href="#">Model Trains Video (2)</a> .....	28
<a href="#">Model Trains Weathered</a> .....	19
<a href="#">Modeler's Guild</a> .....	35
<a href="#">Railflyer Model Prototypes</a> .....	13
<a href="#">Railroad Kits</a> .....	19
<a href="#">Rapido Trains</a> .....	8
<a href="#">Scenic Express</a> .....	40
<a href="#">Scotty Mason Live</a> .....	138
<a href="#">Scotty Mason Show</a> .....	14
<a href="#">ShelfTrax</a> .....	13
<a href="#">Signature Press</a> .....	32
<a href="#">Timesaver Layouts</a> .....	13
<a href="#">TCH Technology</a> .....	34
<a href="#">Tony's Train Exchange</a> .....	79
<a href="#">Train Videos and Parts</a> .....	13
<a href="#">Traintek</a> .....	18

Clickable Topic Index	Page
<a href="#">Editorial – Publisher's Editorial</a> .....	11
<a href="#">Editorial – Reverse Running</a> .....	142
<a href="#">First Look – Trinity Box Hycube</a> .....	122
<a href="#">First Look – Tangent Gondola</a> .....	124
<a href="#">Layouts – Franklin &amp; South Manchester</a> .....	41
<a href="#">Layouts – Housatonic RailRoad Company</a> .....	83
<a href="#">News – March Newsletter</a> .....	20
<a href="#">Photography – New Media Modeler</a> .....	139
<a href="#">Q and A – MRH Questions, Answers, and Tips</a> ...	30
<a href="#">Scenery – Bringing Your Layout Alive</a> .....	80
<a href="#">Scenery – Quick and Easy Hopper Loads</a> .....	39
<a href="#">Scenery – Static Grass Applicators</a> .....	93
<a href="#">Scenery – Up the Creek</a> .....	126
<a href="#">Structures – Up on the Roof</a> .....	51
<a href="#">Track plan – Leaving Las Vegas</a> .....	33
<a href="#">Track plan – Comme-N-tary</a> .....	134
<hr/>	
<a href="#">Other – Cover</a> .....	1
<a href="#">Other – MRH Sponsors</a> .....	2
<a href="#">Other – Table of Contents</a> .....	7

## Coming in the May/June 2010 issue

- The Case for Modeling a Modern Railroad - Lance Mindheim and his new CSX layout
- Diesel detailing made easy
- Visit Jim Dias and his Western Pacific
- Next installment of the Turntable/Roundhouse Series
- The Scenery Scene: retaining walls
- More MRH Questions, Answers and Tips
- Our regular columns

... and lots more!



**For the love of model trains**

[Tell a friend ...](#) [Contents](#) [Index](#)